

HYDAC

INTERNATIONAL



Fluid Analysis Services

Clean Oil For Predictive Maintenance

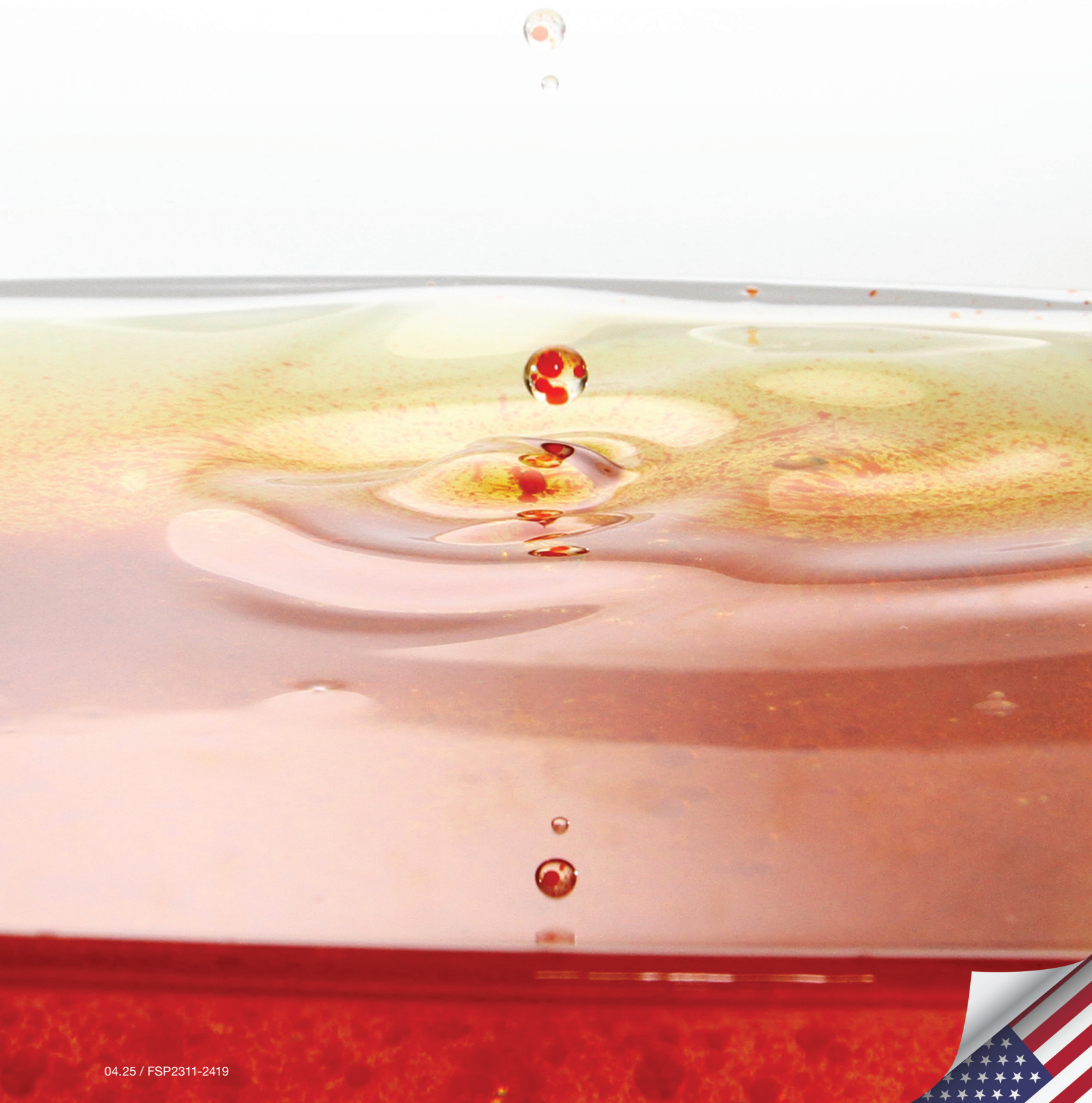

FLUID ANALYSIS SERVICES

Oil analysis is a condition monitoring tool designed to monitor:

- Fluid properties, or the condition of the oil and the additives
- Fluid contamination
- Machine wear

What is the purpose of taking oil samples?

Oil samples can provide insight into the fluid and machine condition at a given point in time. Proper sampling is important in the process of taking bottle samples. The sample taken needs to be representative of the fluid in the system as it is only a small sample of the total oil volume present. Proper sampling of system is dependent upon the following factors:

- Sampling point location
- Sampling equipment used to take the sample
- Sampling method
- Frequency of sampling
- Recent maintenance completed on the system



DO's and DON'T's for Oil Sampling

- ✓ **DO** sample from running machines.
- ✗ **DO NOT** sample “cold” systems.
 - Best time to sample a system is when the system is under normal working load and normal conditions.
- ✓ **DO** sample upstream of filters and downstream of machine components.
 - Taking a sample before and after a filter for a simple particle count will allow you to see how well the filter is currently operating.
- ✓ **DO** create specific written procedures for each system sampled.
 - Identify the sample location
 - Amount of flush volume
 - Frequency of sampling
 - Timing within a cycle to sample
 - Indicate what tools and accessories to use on that specific sample point based on lubricant type, pressure and amount of fluid required.
- ✓ **DO** ensure that sampling valves and sampling devices are thoroughly flushed prior to taking the sample.
 - Cross-contamination has always been a problem in oil sampling. Failure to flush the sample location properly will produce a sample with a high degree of noise.
- ✓ **DO** ensure that samples are taken at proper frequencies.
- ✗ **DO NOT** sample “as time permits”.
 - Setting up the appropriate sampling frequency and adhering to it will allow for precise analysis and sound maintenance decisions.
- ✓ **DO** forward samples immediately to the oil analysis lab after sampling
 - If a problem is detected in a system, the earlier it is detected, the less catastrophic potential it may have.

Oil Sampling Location

In addition to using a clean oil sample bottle, any sampling equipment must also be clean. New microbore hose should be used with each sample that is taken to avoid cross contamination of the sample. The sample needs to be taken from an area of turbulent flow rather than a stagnant location.

Turbulent flow ensures that the sample taken is representative of the fluid in the reservoir.

Samples can be taken from a Sampling or Test Point that can be accessed with a sampling probe or a hand-held vacuum pump. The test point should be one that has been permanently installed at a location where such turbulent flow exists. The test point should be flushed prior to filling the sample bottle per the method outlined below.

Samples can also be taken directly from the hydraulic reservoir using a sampling tube. The sample should be taken a mid point of the reservoir to ensure a representative sample is taken. Samples taken from the top of the reservoir will be significantly cleaner while samples from the bottom of the reservoir will contain significantly higher amounts of contamination.



Oil Sampling Procedure – ISO4021

- Clean all surfaces of sampling point thoroughly
- Operate system for minimum 30 minutes
- Open lock or throttle valve, adjust a flow of about 500 ml/min, flush sampling point with minimum 1 litre (capture oil in a waste reservoir)
- Open lid of sampling bottle now, hold bottle downwards until sampling, fill bottle to 75% level, close lid immediately after sampling. Do not touch sampling outlet in the meantime!
- Close lock or throttle valve
- Label bottle (date, number, fluid type, fluid temperature,

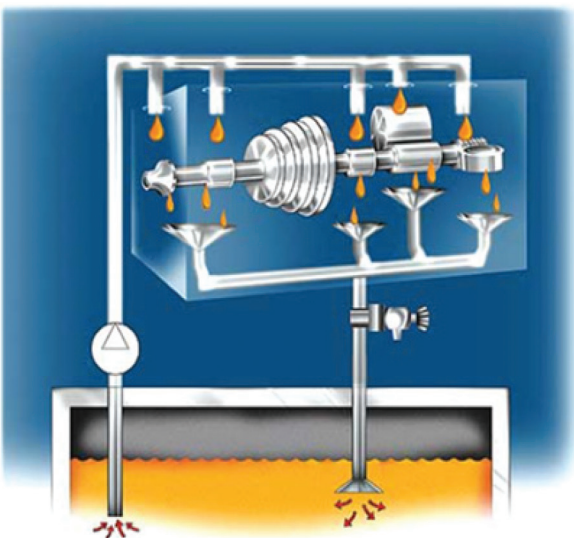
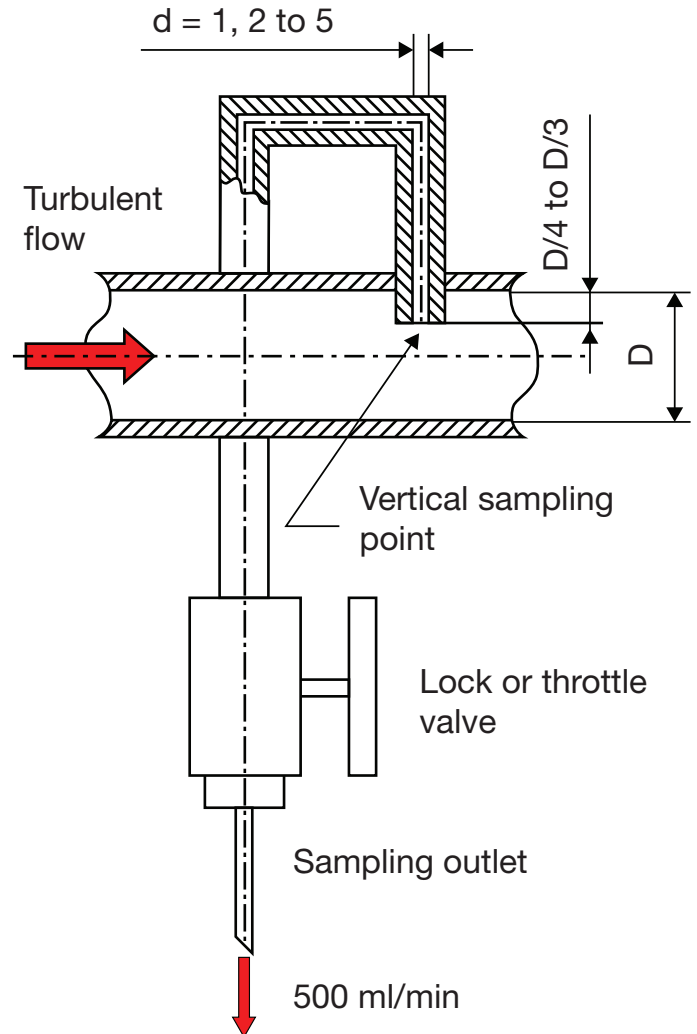
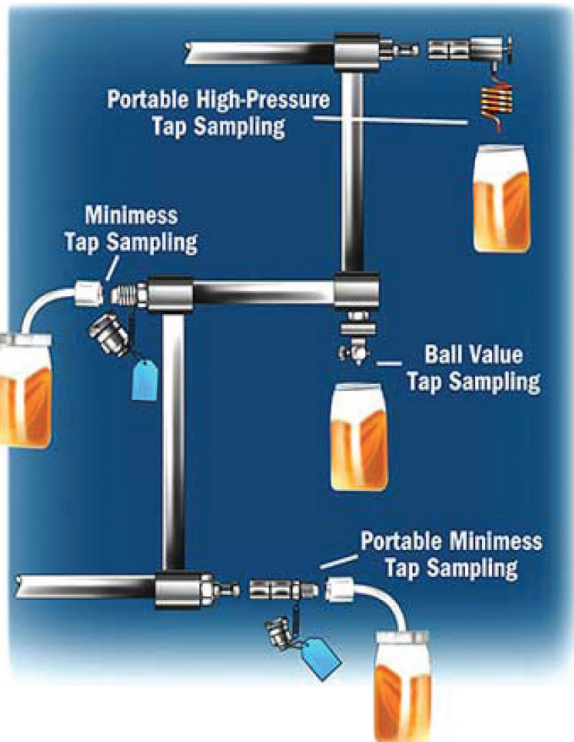

Figure 2. Return or Drain Line

FLUID ANALYSIS SERVICES

Introduction

Clean oil is the key to long equipment life, precision operation, lower maintenance costs and decreased downtime. HYDAC's Fluid Analysis Services can unlock the door to increased savings by detecting potential problems early, so that service/downtime can be scheduled and catastrophic failures/costs can be avoided.

HYDAC's Fluid Analysis Services provide users of industrial and mobile hydraulic equipment with a complete analytical report including:

- System status (rated as Normal, Caution or Critical).
- Graphs of sample and limit data for easy detection of abnormal results.
- Comments and recommendations (where applicable).
- Photo of the contamination contained in the current oil sample. Kits including patch photo are available.
- An oil analysis report will be sent via email to the address provided on the component registration form or is readily available on-line
- Early warning limits based on industry standards, provided targets or a provided baseline.
- Current sample data displayed with up to 10 previous sample results.

A Typical Fluid Analysis Program

HYDAC's Fluid Analysis Services can be used to implement a preventative maintenance program for each critical piece of equipment. The program should begin with a complete examination of the equipment by the customer to determine system criticality and sensitivity, as well as collecting a baseline sample to compare against.

New Oil/Baseline Samples

A sample of new oil should be sent to the lab for analysis. This sample will act as a baseline for comparison with subsequent sample results. New oil/Baseline samples should be taken from the tote after filtering, this will provide the most accurate representation of the oil properties before it is used.

Below is a listing of commonly cited sampling frequencies. These are given as a starting point only. Sampling frequency should be increased as environment severity and system criticality increases.

Sampling Frequency

| Equipment Type | Hours |
|--|-------|
| Hydraulics - Industrial | 700 |
| Hydraulics - Mobile | 200 |
| Hydraulics - Aviation | 150 |
| Steam Turbines | 500 |
| Transmissions | 300 |
| Air/Gas Compressors | 500 |
| Chillers | 500 |
| Gear Boxes - High Speed/Duty | 300 |
| Gear Boxes - Low Speed/Duty | 1000 |
| Bearings - Journal and Rolling Element | 500 |

Sampling Information

The Fluid Analysis Sample Form must be filled out as completely and accurately as possible. Accurate laboratory assessment of your sample depends on it. The most important information is:

- Your Company
- Your Name
- Your Email / Contact Information
- Unit ID / Name
- Date of Sample
- Type of oil (*Manufacturer & Brand*) should be included for most accurate information about your oil sample

HYDAC's Fluid Analysis Services offer our customers a valuable means of extending equipment life, lowering maintenance costs, and decreasing downtime by improving overall system performance using preventative maintenance strategies. To choose the correct program for you please contact your HYDAC distributor or HYDAC directly.

HYDAC Sample Kits and Laboratory Reports

Prepaid Sample Kits

Our Fluid Analysis Service includes testing for mineral oil based fluids, water glycol fluids, grease testing, MPC varnish potential testing, and diesel fuel test kits. Each kit is supplied with a clean sample bottle with mailer bottle, component registration form and prepaid Fluid Analysis Service.

Fluid Analysis Laboratory Reports

For each sample submitted to the lab, our customers will receive complete analytical lab reports including system status and recommendations.



Understanding Your Fluid Analysis Laboratory Report

Status and Recommendations

Corrective actions are recommended when applicable. The status of the sample is rated in three categories:

- **Normal**
 - System is operating within the parameters established by provided limits and/or baseline data.
 - System requires no immediate action.
- **Caution**
 - System is operating outside of caution limits in one or more areas.
 - System requires scheduled maintenance.
- **Critical**
 - System is operating outside of critical limits in one or more areas.
 - System requires immediate attention.

Fluid Laboratory Tests

Using a 100 mL minimum sample, the following tests can be performed:

Particle Count

- Particle Count – ISO CODE representing the number of particles of solid contamination present in a given oil sample
- Water Content – Determination of the amount of water present in a given sample; reported as ppm or percent
- Viscosity – Physical property of a given oil where changes can indicate extent of contamination or degradation; Reported in cSt at 40°C
- TAN – Total Acid Number – Determination of presence of oxidation/organic acids leading to oil degradation; Reported as mg KOH/g
- Spectrographic Analysis – Concentration of additive components, wear metals and contaminate levels reported as ppm

ISO 4406

| Most Sensitive System Component | Low/Medium Pressure Under 2000 psi (moderate conditions) | | High Pressure 2000 to 2999 psi (low/medium with severe conditions*) | | Very High Pressure 3000 psi and over (high pressure with severe conditions*) | |
|-------------------------------------|--|----------------|---|----------------|--|-----------------------|
| | ISO Target Levels | Micron Ratings | ISO Target Levels | Micron Ratings | ISO Target Levels | Micron Ratings |
| Pumps | | | | | | |
| Fixed Gear or Fixed Vane | 20/18/15 | 20 | 19/17/14 | 10 | 18/16/13 | 5 |
| Fixed Piston | 19/17/14 | 10 | 18/16/13 | 5 | 17/15/12 | 3 |
| Variable Vane | 18/16/13 | 5 | 17/15/12 | 3 | <i>not applicable</i> | <i>not applicable</i> |
| Variable Piston | 18/16/13 | 5 | 17/15/12 | 3 | 16/14/11 | 3** |
| Valves | | | | | | |
| Check Valve | 20/18/15 | 20 | 20/18/15 | 20 | 19/17/14 | 10 |
| Directional (solenoid) | 20/18/15 | 20 | 19/17/14 | 10 | 18/16/13 | 5 |
| Standard Flow Control | 20/18/15 | 20 | 19/17/14 | 10 | 18/16/13 | 5 |
| Cartridge Valve | 19/17/14 | 10 | 18/16/13 | 5 | 17/15/12 | 3 |
| Proportional Valve | 17/15/12 | 3 | 17/15/12 | 3 | 16/14/11 | 3** |
| Servo Valve | 16/14/11 | 3** | 16/14/11 | 3** | 15/13/10 | 3** |
| Actuators | | | | | | |
| Cylinders, Vane Motors, Gear Motors | 20/18/15 | 20 | 19/17/14 | 10 | 18/16/13 | 5 |
| Piston Motors, Swash Plate Motors | 19/17/14 | 10 | 18/16/13 | 5 | 17/15/12 | 3 |
| Hydrostatic Drives | 16/15/12 | 3 | 16/14/11 | 3** | 15/13/10 | 3** |
| Test Stands | 15/13/10 | 3** | 15/13/10 | 3** | 15/13/10 | 3** |
| Bearings | | | | | | |
| Journal Bearings | 17/15/12 | 3 | — | — | — | — |
| Industrial Gearboxes | 17/15/12 | 3 | — | — | — | — |
| Ball Bearings | 15/13/10 | 3** | — | — | — | — |
| Roller Bearings | 16/14/11 | 3** | — | — | — | — |

* Severe conditions may include high flow surges, pressure spikes, frequent cold starts, extremely heavy duty use, or the presence of water.

** Two or more system filters of the recommended rating may be required to achieve and maintain the desired Target Cleanliness Level.

FLUID ANALYSIS SERVICES

Fluid Analysis Test Packages

Clean oil is the key to long equipment life, precision operation, lower maintenance costs and decreased downtime. HYDAC's Fluid Analysis Services can unlock the door to increased savings by detecting potential problems early, so that service/downtime can be scheduled and catastrophic failures/costs can be avoided.

HYDAC's Fluid Analysis Services provide users of industrial and mobile hydraulic equipment with a complete analytical report available on our Fluid Care Portal including:

- System status (*rated as Normal, Caution or Critical*)
- Graphs of sample and limit data for easy detection of abnormal results
- Photo of the contamination contained in the current oil sample
- An oil analysis report will be readily available on-line
- Early warning limits based on industry standards, provided targets or a provided baseline.
- Sample Data saved in the Fluid Care Portal for trending

Information gained by using this service can help identify potential problems in a hydraulic system at minimal cost to the user. Fluid Analysis can provide answers to important questions such as these:

- Do I have the right filtration system in place for efficient contamination control?
- Is the fluid in my system experiencing changes that could negatively impact component life or system performance?

HYDAC offers several types of sample kits for analysis of Hydraulic Fluids:

BASIC OIL ANALYSIS KIT, BOX 10 – p/n 2219744 - ■

ADVANCED OIL ANALYSIS KIT, BOX 10 – p/n 2219746 - ■

PREMIUM OIL ANALYSIS KIT, BOX 10 - p/n 2219745 - ■

| Test Kit Type | Test Kit Items |
|---------------|---|
| ■ | Appearance Bottle Photo |
| ■ | ISO Particle Count Performed by ISO 11500, reported by ISO4406 |
| ■ | Filter Patch Photo of filter patch |
| ■ | Karl Fischer Water % ASTM D6304C |
| ■ | Viscosity at 40C* ASTM D445 |
| ■ | Viscosity at 100C* ASTM D445 |
| ■ | Viscosity Index ASTM D2270 |
| ■ | ICP Spectrometry ASTM D5185 |
| ■ | Total Acid Number (TAN) ASTM D664 |
| ■ | Varnish Potential (MPC) ASTM D7843 |

*Advanced kits will be read at 40C or 100C depending on the viscosity of the fluid. There will only be one reading on the report.

Upon receipt of order for any of these part numbers, a sample kit containing a clean sample bottle, blank form, and mailing envelope is shipped to the customer. After the sample has been taken, the customer simply completes the form, encloses it along with the sample in the mailing envelope provided and sends it off to the lab. Kits are packaged and sold in lots of 10.

HYDAC offers kits to test COOLANTS:

The BASIC and ADVANCED Oil Analysis kits can also be used for testing COOLANTS! Simply indicate on the Component Registration Form that the hydraulic fluid is a COOLANT and include Coolant manufacturer and brand name.

| Test Kit Type | Test Kit Items |
|---------------|---|
| ■ | Appearance Color, Clarity, Oder, Precipitates |
| ■ | pH |
| ■ | Conductivity - Coolants |
| ■ | Refractive Index Freeze Point, Boiling Point, % Glycol |
| ■ | Nitrates by Titration % Water ASTM D6304 |
| ■ | Sediment Patch Photo of Filter Patch |

Grease Test Packages:

Monitoring the machine fluid condition is one importance aspect of an effective condition monitoring program, however an often overlooked machine component is the Grease. Staying on top of the condition of the grease used within the machine allows you to monitor your equipment condition and identify issues before catastrophic failure occurs. By monitoring grease conditions you can minimize unplanned repairs by tracking degradation trends and wear rates leading to a decrease in downtime, extension of machine life and increase equipment reliability.

HYDAC offers several types of sample kits for analysis of Greases:

BASIC GREASE TEST PACKAGE – p/n 2219851 - ■

ADVANCED GREASE TEST PACKAGE – p/n 2219852 - ■

| Test Kit Type | Test Kit Items |
|---------------|--|
| ■ | Color Visual Color |
| ■ | Total Magnetic Iron (TMI) Ferrous Screening |
| ■ | FTIR Oxidation Direct Trend Method |
| ■ | ICP Spectrometry 25 Element ASTM D5185-05 |
| ■ | Karl Fischer % Water ASTM D6304 |
| ■ | RULER Remaining Useful Life |
| ■ | Penetration Test Quarter Cup |
| ■ | Ferrography Photographic Report |

I-128581

KDBM

Page 2

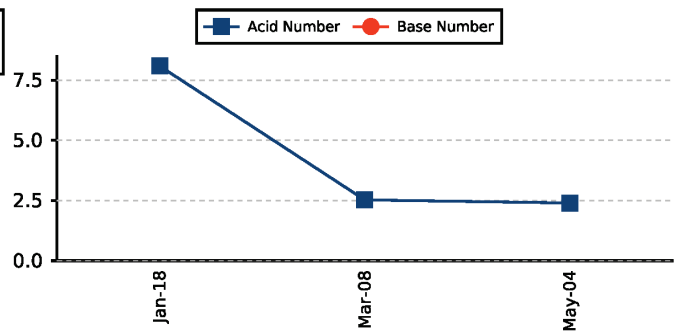
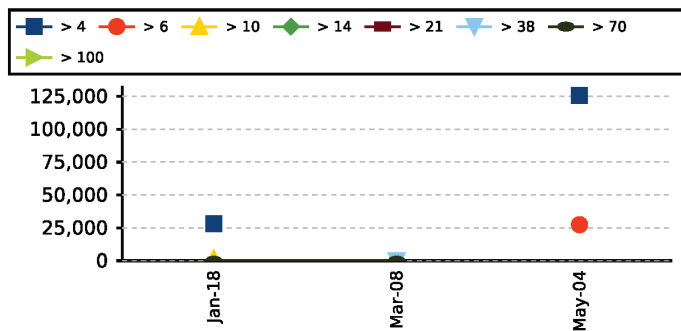
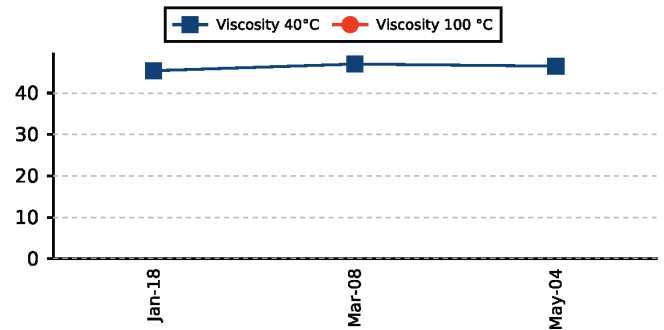
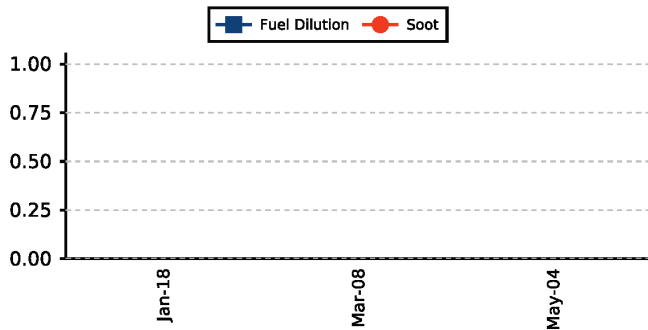
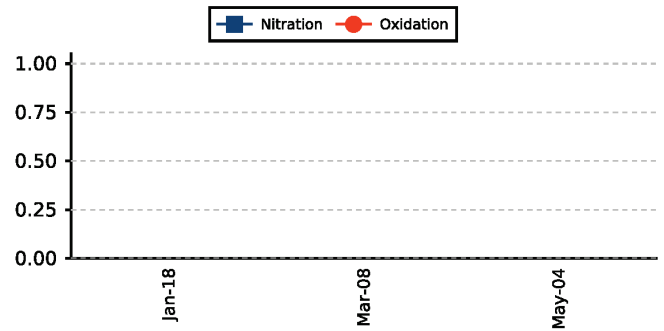
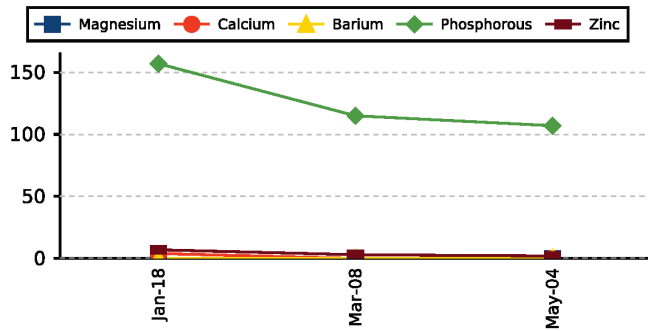
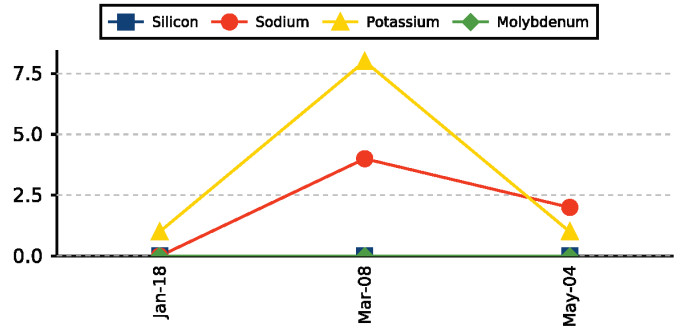
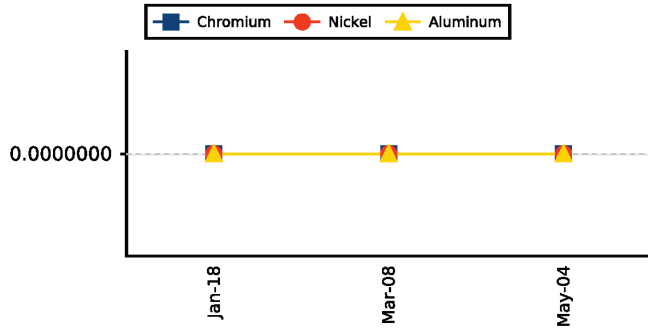
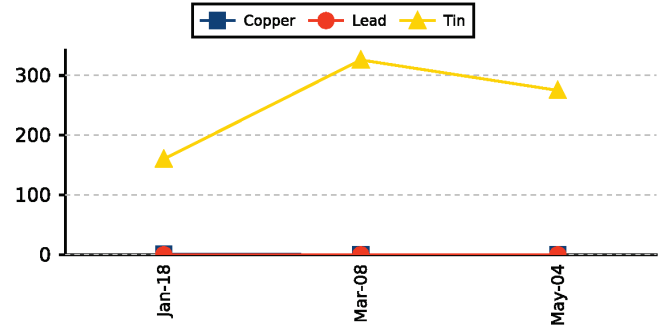
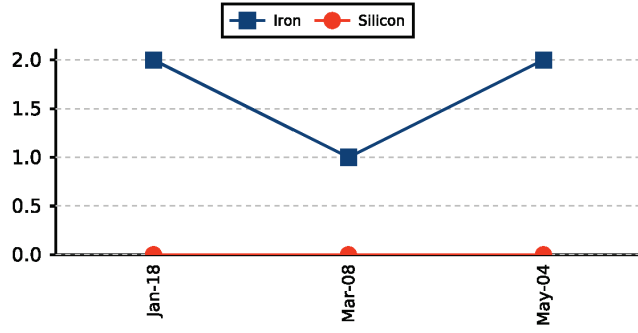



INTERNATIONAL

Global Headquarters
HYDAC INTERNATIONAL
GMBH

Industriegebiet
D – 66280 Sulzbach/Saar
Germany

Tel.: +49 6897 509-01

Fax: +49 6897 509-577

Internet: www.hydac.com
Email: info@hydac.com



Evolution Motion Solutions

13835 Senlac Dr,
Farmers Branch, TX 75234
800-569-9801

info@evolutionmotion.com |
evolutionmotion.com

North America Locations

USA

www.HYDAC.com/EN-US

North America Headquarters
HYDAC TECHNOLOGY CORPORATION
Filter Division

2260 City Line Road
Bethlehem, PA 18017
+1.610.266.0100

HYDAC TECHNOLOGY CORPORATION
Electronic Division
Process Filter Division

HYDAC CORPORATION
Accumulator Division
90 Southland Drive
Bethlehem, PA 18017
+1.610.266.0100

HYDAC TECHNOLOGY CORPORATION
Accessory Division

2204 Avenue C
Bethlehem, PA 18017
+1.610.266.0100

HYDAC TECHNOLOGY CORPORATION
Filter System Division
Process Filter Division
Fuel Filtration Division

580 West Park Road
Leetsdale, PA 15056
+1.724.318.1100

HYDAC TECHNOLOGY CORPORATION
Hydraulic Division –
Compact Hydraulics

450 / 445 Windy Point Drive
Glendale Heights, IL 60139
+1.630.545.0800

HYDAC TECHNOLOGY CORPORATION
Hydraulic Division – Tech Center

430 Windy Point Drive
Glendale Heights, IL 60139
+1.630.545.0800

HYDAC TECHNOLOGY CORPORATION
Cooling System Division

1051 Airlie Parkway
Denver, NC 28037
+1.610.266.0100

HYDAC TECHNOLOGY CORPORATION
Mobile Hydraulic Division

4047 Lincoln Way E • Building D
Wooster, OH 44691
+1.610.266.0100

HYDAC CYLINDERS LLC

540 Carson Road North
Birmingham, AL 35217
+1.205.520.1220

HYDAC TECHNOLOGY CORPORATION
HYDAC CORPORATION
Sales Office & Operations

510 Stonegate Drive
Katy, TX 77494
+1.281.579.8100

HYDAC TECHNOLOGY CORPORATION
HYDAC CORPORATION
NW Sales Office & Operations

1201 NE 144th St. Bldg. B • Suite 111
Vancouver, WA 98685
+1.610.266.0100

HYDAC TECHNOLOGY CORPORATION
HYDAC CORPORATION
NE Sales Office

4047 Lincoln Way E • Building D
Wooster, OH 44691
+1.610.266.0100

HYDAC TECHNOLOGY CORPORATION
HYDAC CORPORATION
SE Sales Office

1051 Airlie Parkway
Denver, NC 28037
+1.610.266.0100

HYDAC TECHNOLOGY CORPORATION
HYDAC CORPORATION
NC Sales Office

300 N. Corporate Drive • Suite 215
Brookfield, WI 53045
+1.610.266.0100

Canada

www.HYDAC.com/EN-CA

HYDAC CORPORATION

14 Federal Road
Welland, Ontario, Canada L3B 3P2
+1.905.714.9322

HYDAC CORPORATION
Sales Office

5160 75 Street NW
Edmonton, Alberta, Canada T6E 6W2
+1.780.484.4228

HYDAC CORPORATION
Sales Office

Montreal, Québec, Canada J2M 1K9
+1.877.539.3388

Mexico

www.HYDAC.com/ES-MX

HYDAC INTERNATIONAL SA de CV

Calle Alfredo A Nobel No 35
Col Puente de Vigas
Tlalhepantla, Edo Mexico
CP 54090
Mexico
+011.52.55.4777.1262