

# Pressure relief valve, direct operated

## Type DBD



- ▶ Size 6 ... 30
- ▶ Component series 1X
- ▶ Maximum operating pressure 630 bar
- ▶ Maximum flow 330 l/min



### Features

- ▶ As screw-in cartridge valve (cartridge)
- ▶ For threaded connection
- ▶ For subplate mounting
- ▶ Adjustment types for pressure adjustment, optionally:
  - Bushing with hexagon and protective cap
  - Rotary knob
  - Hand wheel
  - Lockable rotary knob
- ▶ Corrosion-protected design

### Contents

Features	1
Ordering code	2, 3
Function, section, symbol	4
Technical data	5, 6
Characteristic curves	7, 8
Dimensions	9 ... 13

### Type-examination tested safety valves type DBD...E according to Pressure Equipment Directive 2014/68/EU

Ordering code	14
Deviating technical data	15
Characteristic curves	16
Deviating dimensions	17
Sheet cut-out for front panel mounting	18
Safety instructions	19
Counter pressure in the discharge line	19 ... 23
Further information	24

**Ordering code**

01	02	03	04	05	06	07	08	09	10	11
DBD				1X	/					*

01	Pressure relief valve, direct operated	DBD
----	--	-----

**Adjustment type for pressure adjustment**

02		NG6	NG8	NG10	NG15	NG20	NG25	NG30		
	Bushing with hexagon and protective cap	✓	✓	✓	✓	✓	✓	✓	S	◇
	Rotary knob <sup>1)</sup>	✓	✓	✓	✓	✓	-	-	H	
	Hand wheel <sup>2)</sup>	-	-	-	-	-	✓	✓	H	
	Lockable rotary knob <sup>1; 3; 4)</sup>	✓	✓	✓	✓	✓	-	-	A	

03	Size 6 (port G1/4)	6	◇
	Size 8 (port G3/8)	8	
	Size 10 (port G1/2)	10	◇
	Size 15 (port G3/4)	15	
	Size 20 (port G1)	20	◇
	Size 25 (port G1 1/4)	25	
	Size 30 (port G1 1/2)	30	◇

**Type of connection**

04		NG6	NG8	NG10	NG15	NG20	NG25	NG30		
	As screw-in cartridge valve (cartridge)	✓	-	✓	-	✓	-	✓	K	◇
	For threaded connection	✓	✓	✓	✓	✓	✓	✓	G	◇
	For subplate mounting	✓	-	✓	-	✓	-	✓	P	

05	Component series 10 ... 1Z (10 ... 1Z: unchanged installation and connection dimensions)	1X
----	--	----

**Pressure rating <sup>5)</sup>**

06		NG6	NG8	NG10	NG15	NG20	NG25	NG30		
	Set pressure up to 25 bar	✓	✓	✓	✓	✓	✓	✓	25	
	Set pressure up to 50 bar	✓	✓	✓	✓	✓	✓	✓	50	
	Set pressure up to 100 bar	✓	✓	✓	✓	✓	✓	✓	100	◇
	Set pressure up to 200 bar	✓	✓	✓	✓	✓	✓	✓	200	◇
	Set pressure up to 315 bar	✓	✓	✓	✓	✓	✓	✓	315	◇
	Set pressure up to 400 bar	✓	✓	✓	✓	✓	-	-	400	
	Set pressure up to 630 bar <sup>6)</sup>	-	-	✓	-	-	-	-	630	

**Corrosion resistance** (for availability see table on page 3)

07	None	no code	◇
	Improved corrosion protection (240 h salt spray test according to EN ISO 9227)	J3	
	High corrosion protection (720 h salt spray test according to EN ISO 9227)	J5	

**Seal material** (observe compatibility of seals with hydraulic fluid used, see page 6)

08	NBR seals	no code	◇
	FKM seals	V	

**Line connection**

09	Pipe thread according to ISO 228/1	no code	◇
	SAE thread	/12	

**Equipment Directive**

10	Without type-examination procedure	no code	◇
	Type-examination tested safety valves according to Pressure Equipment Directive 2014/68/EU <sup>7)</sup>	E	

11	Further details in the plain text	
----	-----------------------------------	--

## Ordering code

- 1) For size 15 and 20, only available for the pressure ratings 25, 50 or 100 bar.
- 2) Available for the pressure ratings 25, 50 or 100 bar only.
- 3) Key with material no. **R900008158** is included in the scope of delivery.
- 4) Not for type-examination tested safety valves "E".
- 5) When selecting the pressure rating, please observe the characteristic curves and notes on page 8.
- 6) With version "G" and "P," only available as "SO292," see page 9 and 12.
- 7) See ordering code on page 14.

 **Notice:** ♦ = Preferred type

### Availability corrosion resistance (Without type-examination procedure; only adjustment type "S")

Type of connection	NG6	NG8	NG10	NG15	NG20	NG25	NG30
As screw-in cartridge valve "K"	no code, J5	–	no code, J5	–	no code, J5	–	no code, J5
For threaded connection "G"	no code, J3	no code	no code, J3	no code	no code, J3	no code	no code, J3
For subplate mounting "P"	no code, J3	–	no code, J3	–	no code, J3	–	no code, J3

 **Notice:**  
Deviating ordering code for type-examination tested safety valves "E" can be found on page 14.

## Function, section, symbol

Pressure relief valve type DBD are direct operated seat valves. They are used for limiting a system pressure.

The valves basically consist of a sleeve (1), spring (2), poppet with damping piston (3) (pressure rating 25 ... 400 bar) or ball (4) (pressure rating 630 bar) and adjustment type (5). The system pressure can be set steplessly via the adjustment type (5). The spring (2) pushes the poppet (3) or the ball (4) onto the seat. Channel P is connected to the system. The pressure existing in the system acts on the poppet surface (or the ball).

If the pressure in channel P exceeds the value set at the spring (2), the poppet (3) or the ball (4) opens against the spring (2). Now, hydraulic fluid from channel P flows into channel T. The stroke of the poppet (3) is limited by the embossing (6).

In order to achieve good pressure adjustment over the entire pressure range, the entire pressure range has been divided into 7 pressure ratings. One pressure rating corresponds to a certain spring for a maximum operating pressure that can be set by means of that spring.

### Notice:

The adjustment type (5) is constructed so that it cannot be lost. Due to the gimbal-mounting, the adjustment element remains loose (movable) in the adjustment type (5) in case of complete unloading.

Pressure rating "25":

If despite completely unloaded adjustment type, the minimum pressure does not settle, the adjustment element has to be "pulled back" to the stop due to the low spring and/or restoring force.

For pressure adjustment / increase, the adjustment element can then be screwed in again.

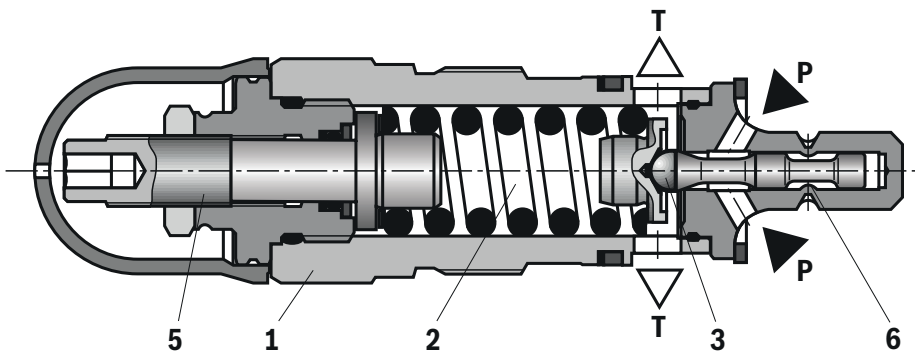

### Type DBDS..K1X/...

Version with pressure rating 25 ... 400 bar  
(poppet seat valve)

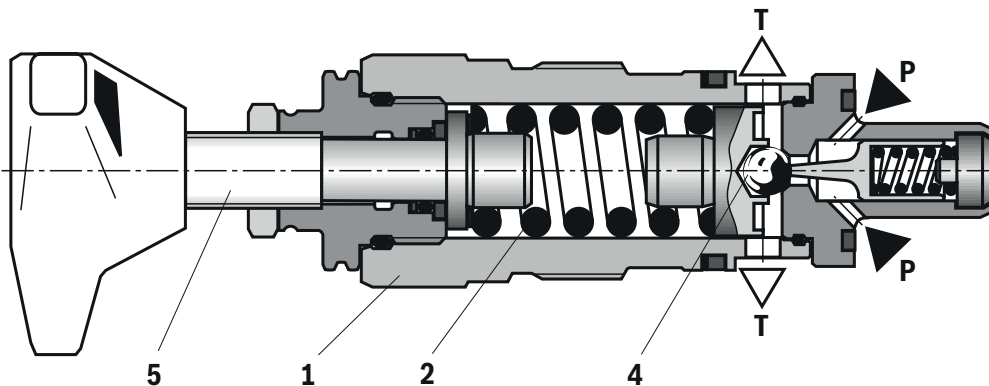

### Type DBDH 10 K1X/...

Version with pressure rating 630 bar (ball seat valve,  
only NG10)

### Symbol

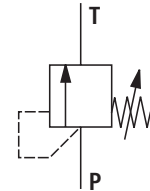

## Technical data

(For applications outside these values, please consult us!)

General					
Size	NG	6, 8	10	15, 20	25, 30
Type of connection		Subplate mounting; threaded connection; screw-in cartridge valve			
Weight		See pages 9, 11 and 12			
Installation position		Any			
Ambient temperature range	°C	-20 ... +80 (NBR seals) -15 ... +80 (FKM seals)			
MTTF <sub>D</sub> values according to EN ISO 13849	Years	150 ... 1200 (for more information see data sheet 08012)			

Hydraulic						
Maximum operating pressure	► Port P					
	– Standard	bar	400	400	400	315
	– Version "630"	bar	–	630	–	–
	► Port T	bar	315	315	315	315
Hydraulic fluid		See table page 6				
Hydraulic fluid temperature range	°C	-20 ... +80 (NBR seals) -15 ... +80 (FKM seals)				
Viscosity range	mm <sup>2</sup> /s	10 ... 800				
Maximum admissible degree of contamination of the hydraulic fluid; cleanliness class according to ISO 4406 (c)		Class 20/18/15 <sup>1)</sup>				
Maximum flow (standard valves)		See characteristic curves page 8				
Minimum set pressure		See characteristic curves page 7				

<sup>1)</sup> The cleanliness classes specified for the components must be adhered to in hydraulic systems. Effective filtration prevents faults and at the same time increases the life cycle of the components.

### Notice:

► Hydraulic counter pressures in port T add 1:1 to the response pressure of the valve set at the adjustment type.

#### Example:

- Pressure adjustment of the valve due to spring preload (item 2 on page 4)  $p_{\text{spring}} = 200 \text{ bar}$
- Hydraulic counter pressure in port T:  $p_{\text{hydraulic}} = 50 \text{ bar}$
- ⇒ Response pressure =  $p_{\text{spring}} + p_{\text{hydraulic}} = 250 \text{ bar}$

► Deviating technical data for type-examination tested safety valves can be found on page 15.

**Technical data**

(For applications outside these values, please consult us!)

Hydraulic fluid	Classification	Suitable sealing materials	Standards	Data sheet
Mineral oils	HL, HLP, HLPD, HVLP, HVLPD	NBR, FKM	DIN 51524	90220
Bio-degradable	▶ Insoluble in water	HETG	ISO 15380	90221
		HEES		
	▶ Soluble in water	HEPG	ISO 15380	
Flame-resistant	▶ Water-free	HFDU (glycol base)	ISO 12922	90222
		HFDU (ester base)		
		HFDR		
	▶ Containing water	HFC (Fuchs: Hydrotherm 46M, Renosafe 500; Petrofer: Ultra Safe 620; Houghton: Safe 620; Union: Carbide HP5046)	NBR	ISO 12922

**Important information on hydraulic fluids:**

- ▶ For further information and data on the use of other hydraulic fluids, please refer to the data sheets above or contact us.
- ▶ There may be limitations regarding the technical valve data (temperature, pressure range, life cycle, maintenance intervals, etc.).
- ▶ The ignition temperature of the hydraulic fluid used must be 50 K higher than the maximum surface temperature.
- ▶ **Bio-degradable and flame-resistant – containing water:**  
If components with galvanic zinc coating (e.g., version "J3" or "J5") or parts containing zinc are used, small amounts of dissolved zinc may get into the hydraulic system and cause accelerated aging of the hydraulic fluid. Zinc soap may form as a chemical reaction product, which may clog filters, nozzles and solenoid valves – particularly in connection with local heat input.

**▶ Flame-resistant – containing water:**

Due to the increased cavitation tendency with HFC hydraulic fluids, the life cycle of the component may be reduced by up to 30% as compared to the use with mineral oil HLP. In order to reduce the cavitation effect, it is recommended – if possible specific to the installation – backing up the return flow pressure in ports T to approx. 20% of the pressure differential at the component.

## Characteristic curves

(measured with HLP46,  $\vartheta_{oil} = 40 \pm 5 \text{ } ^\circ\text{C}$ )

### Minimum set pressure

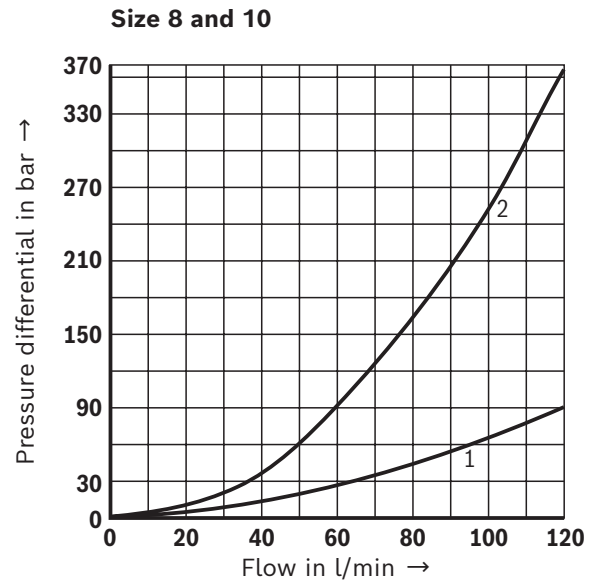
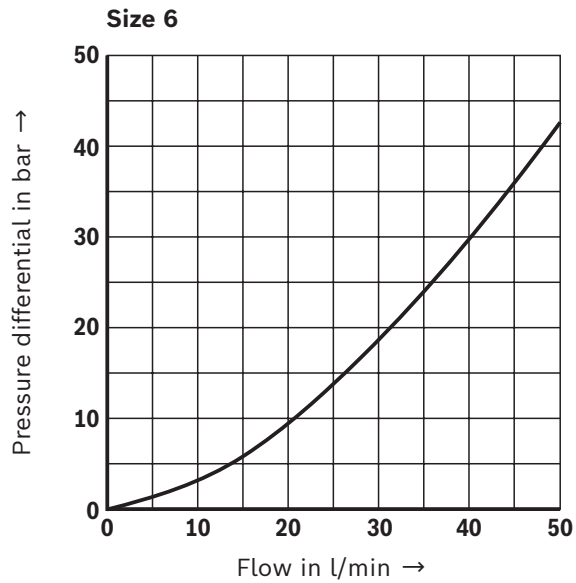

- 1 Pressure rating 25 ... 400 bar
- 2 Pressure rating 630 bar

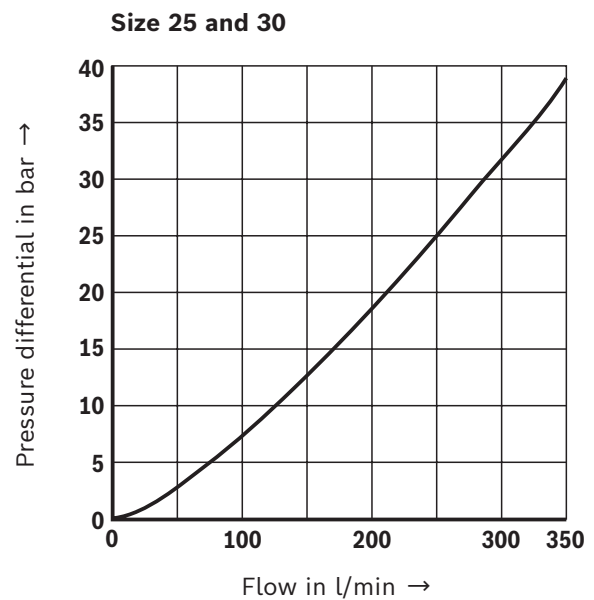
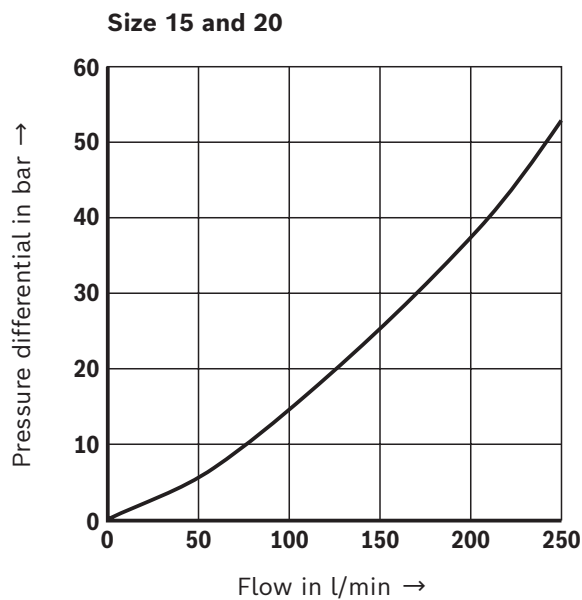

#### Notice:

Typical characteristic curves which are subject to tolerance variations.

### Characteristic curves

(measured with HLP46,  $\vartheta_{oil} = 40 \pm 5 \text{ }^\circ\text{C}$ )

#### $\Delta p$ - $q_v$ characteristic curves

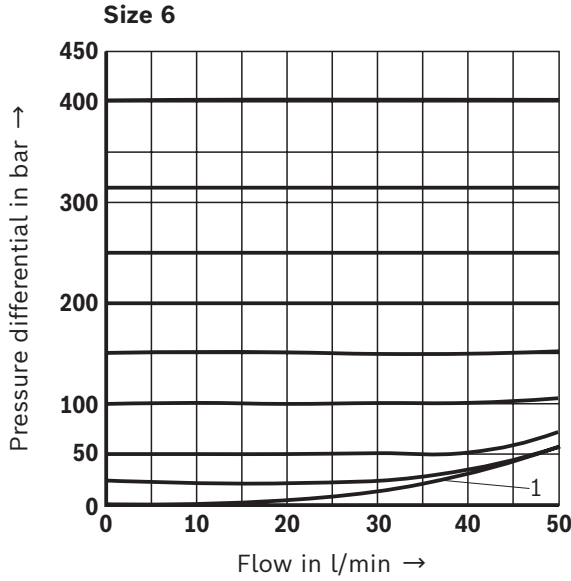

1 minimum adjustable pressure

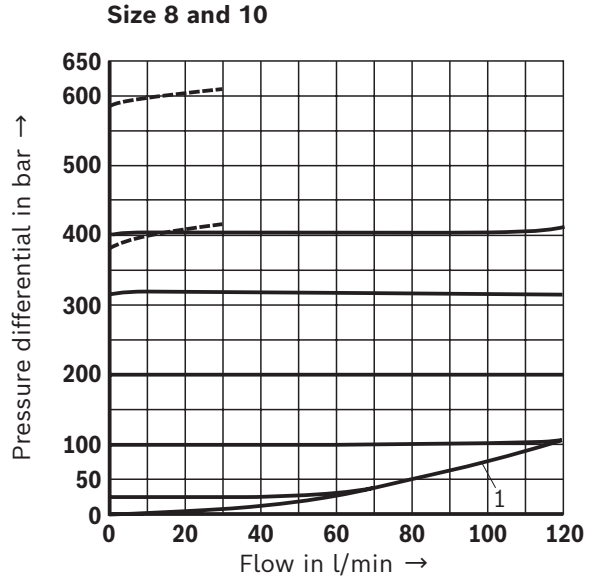

--- Pressure rating 630 bar (NG10 only)

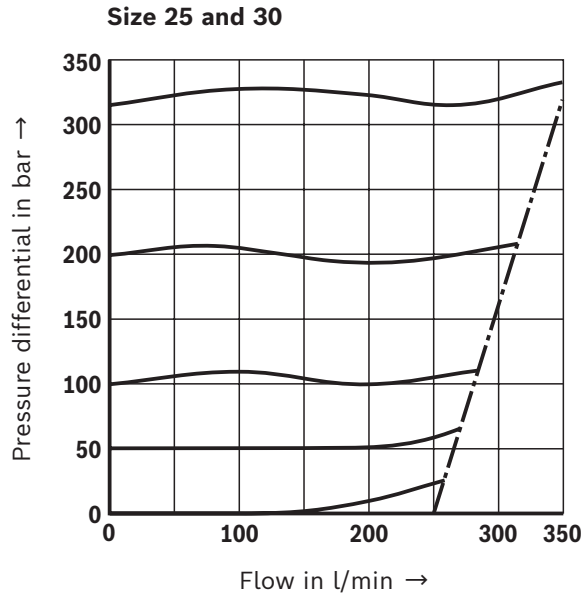
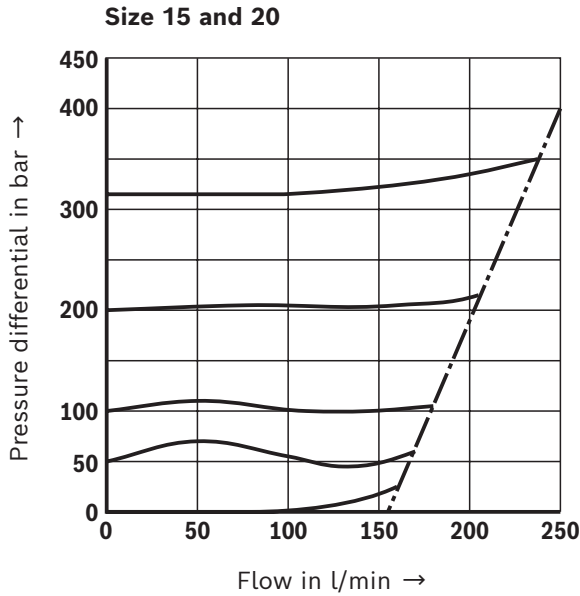

**Notice:**

- ▶ The characteristic curves apply for output pressure  $p_T = 0$  bar in the entire flow range.
- ▶ The characteristic curves only apply with the specified environmental and temperature conditions. It has to be noted that any deviations from the specified boundary conditions will affect the characteristic curve.

- ▶ The characteristic curves refer to the specified pressure ratings (e.g. 200 bar). The more the set pressure value differs from the nominal pressure rating (e.g. <200 bar), the larger the pressure increase with increasing flow gets.
- ▶ Typical characteristic curves which are subject to tolerance variations.

**Dimensions:** Threaded connection  
(dimensions in mm)

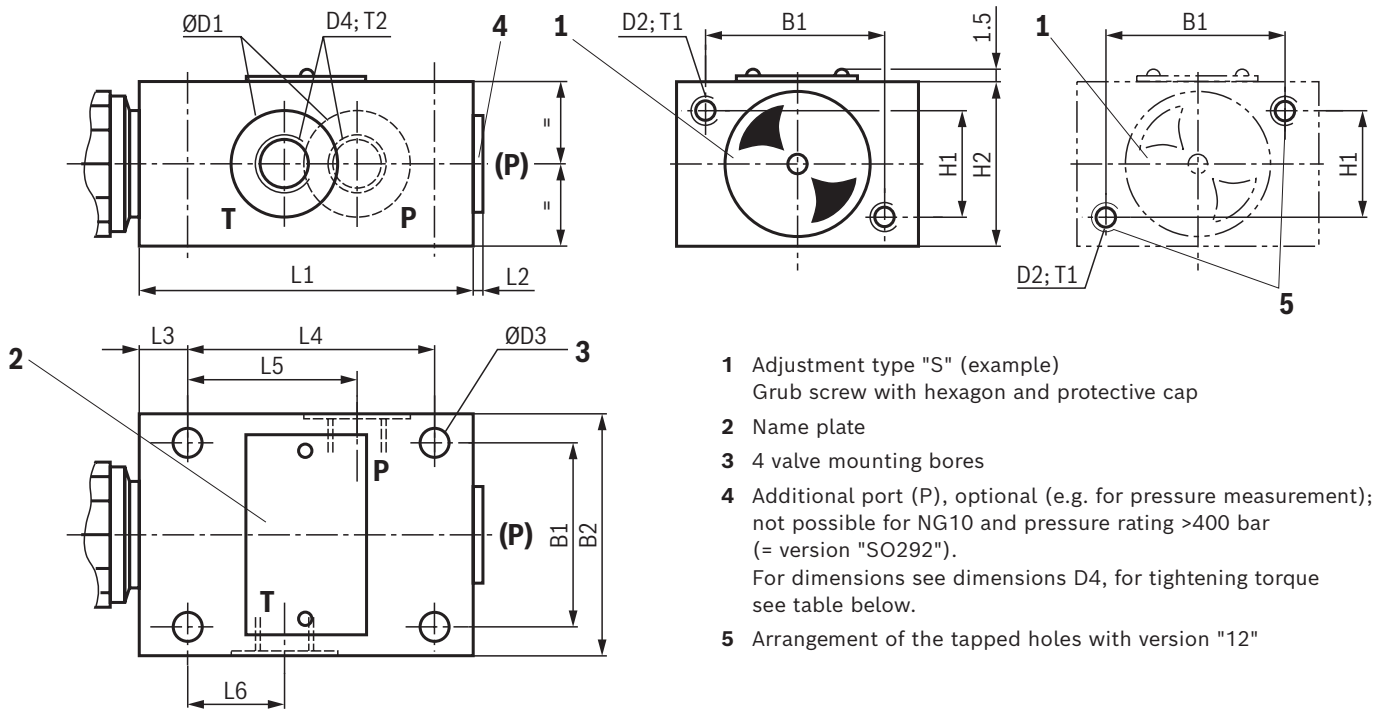

NG	B1	B2	ØD1 <sup>1)</sup>	D2 <sup>1)</sup>	ØD3	D4 <sup>1)</sup>	Tightening torques $M_A$ in Nm <sup>2)</sup>	
							Plug screw (4) <sup>1)</sup>	Pipe fittings
6	45	60	25	M6	6.6	G1/4	30	60
8	60	80	28	M8	9	G3/8	55	90
10	60	80	34	M8	9	G1/2	80	130
15	70	100	42	M8	9	G3/4	135	200
20	70	100	47	M8	9	G1	225	380
25	100	130	56	M10	11	G1 1/4	480	500
30	100	130	65	M10	11	G1 1/2	605	600

NG	H1	H2	L1	L2	L3	L4	L5	L6	T1	T2 <sup>1)</sup>	Weight, approx. in kg
6	25	40	80	4	15	55	40	20	10	12	1.5
8	40	60	100	4	20	70	48	21	15	12	3.7
10	40	60	100	4	20	70	48	21	15	14	3.7
15	50	70	135	4	20	100	65	34	18	16	6.4
20	50	70	135	5.5	20	100	65	34	18	18	6.4
25	60	90	180	5.5	25	130	85	35	20	20	13.9
30	60	90	180	12	25	130	85	35	20	22	13.9

**1) Different dimensions for version "/12"**

NG	ØD1	D2	D4	T2	Tightening torques $M_A$ in Nm <sup>2)</sup>	
					Plug screw (4)	
6	21	1/4"-20 UNC	7/16"-20 UNF	12		18
8	25	5/16"-18 UNC	9/16"-18 UNF	13		35
10	32	5/16"-18 UNC	3/4"-16 UNF	15		70
15	41	5/16"-18 UNC	1 1/16"-12 UN	20		170
20	49	5/16"-18 UNC	1 5/16"-12 UN	20		270
25	58	3/8"-16 UNC	1 5/8"-12 UN	20		320
30	70	3/8"-16 UNC	1 7/8"-12 UN	16		480

<sup>2)</sup> The tightening torques are guidelines, referring to the maximum operating pressure and when using a manual torque wrench (tolerance ±10%).

For the **versions** and **dimensions** of the adjustment types refer to page 10 and 11.

**Dimensions:** Screw-in cartridge valve  
(dimensions in mm)

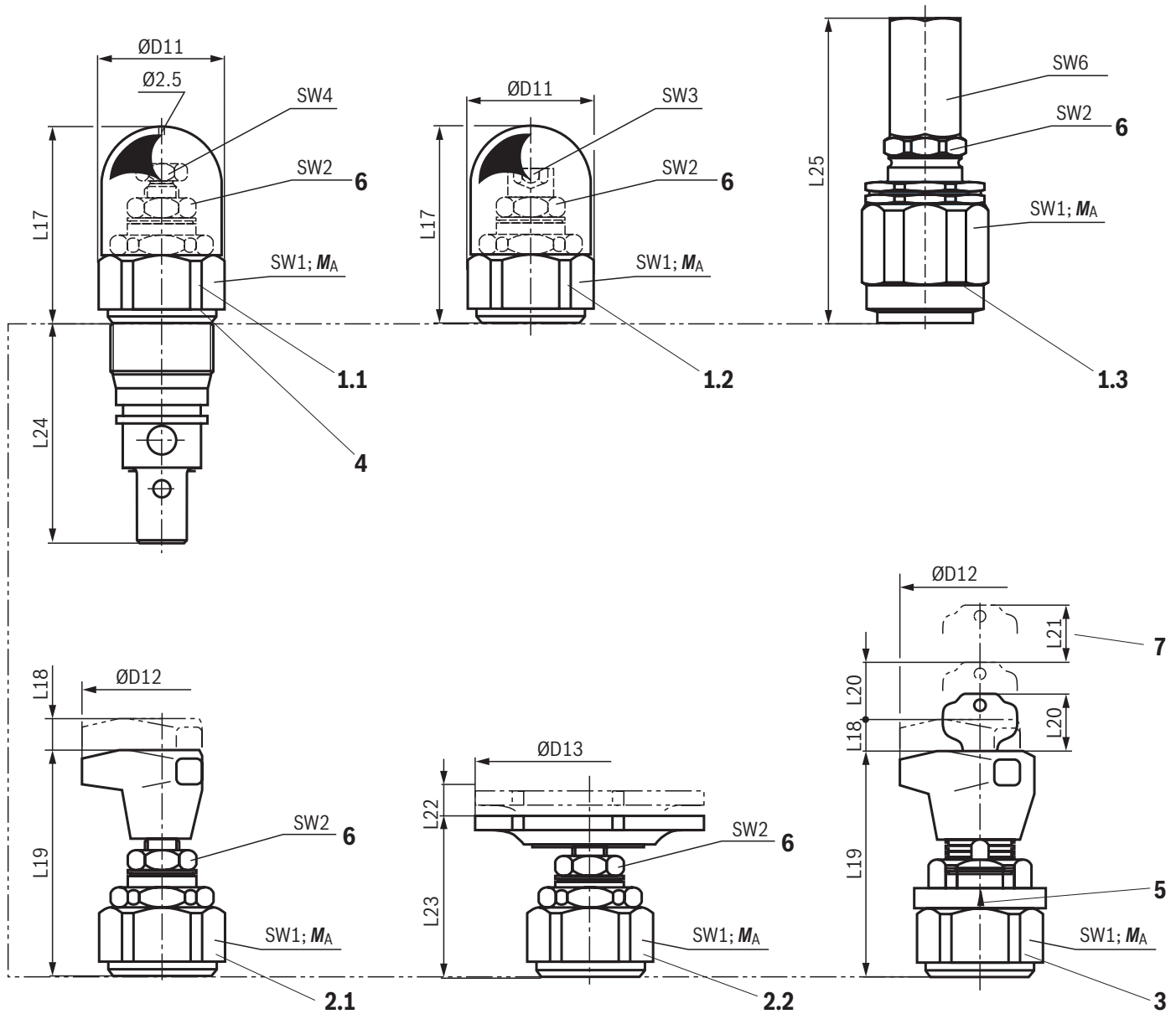

- 1.1 Adjustment type "S" – Sleeve with hexagon and protective cap (NG30)
- 1.2 Adjustment type "S" – Sleeve with internal hexagon and protective cap (NG6 ... NG20)
- 1.3 Adjustment type "S" – Sleeve with hexagon and protective cap; version "J3" and "J5"
- 2.1 Adjustment type "H" – rotary knob (NG6 ... NG20)
- 2.2 Adjustment type "H" – hand wheel (NG30)
- 3 Adjustment type "A" – lockable rotary knob NG6 ... NG10 (NG20 ... 100 bar)
- 4 Type designation

- 5 Marking (adjustment of the zero position after the valve has been screwed in; then fixing of the ring by horizontal shifting until it engages on the plug screw SW6).
- 6 Lock nut, tightening torque  $M_A = 10^{+5}$  Nm
- 7 Space required to remove the key

**Dimensional tables** see page 11, **installation bore** see page 13.

**Dimensions:** Screw-in cartridge valve  
(dimensions in mm)

NG	ØD11	ØD12	ØD13	L17	L18	L19	L20	L21	L22	L23	L24	L25
6	34	60	–	72	11	83	28	20	–	–	64.5	82.2
10	38	60	–	68	11	79	28	20	–	–	77	78.5
20	48	60	–	65	11	77	28	20	–	–	106	75
30	63	–	80	83	–	–	–	–	11	56	131	94.3

NG	SW1	SW2	SW3	SW4	SW5	SW6	Tightening torques $M_A$ in Nm for screw-in cartridge valves <sup>2)</sup>			Weight, approx. in kg
							Pressure rating in bar			
							up to 200	up to 400	up to 630	
6	32	19	6	–	30	19	50±5	80±5	–	0.4
10	36	19	6	–	30	19	100±5	150±10	200±10	0.5
20	46	19	6	–	30	19	150±10	300±15	–	1
30	60	19	–	13	–	19	350±20	500±30	–	2.2

<sup>2)</sup> The tightening torques are guidelines with a friction coefficient  $\mu_{\text{total}} = 0.12$  and when using a manual torque wrench.

**Dimensions:** Subplate mounting  
(dimensions in mm)

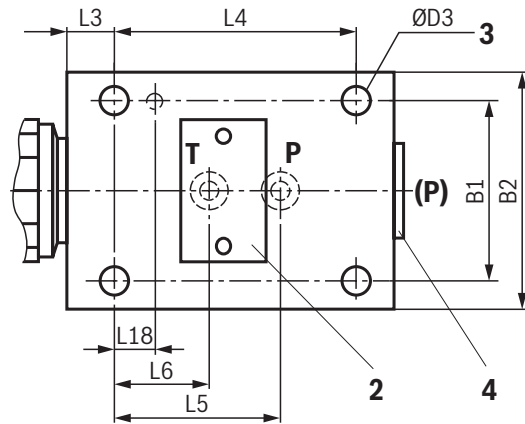
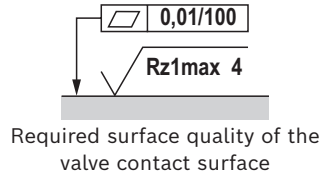
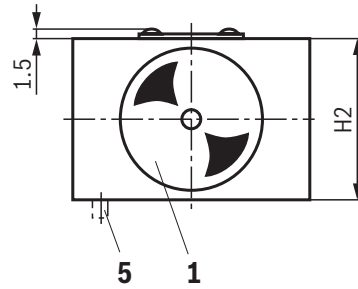
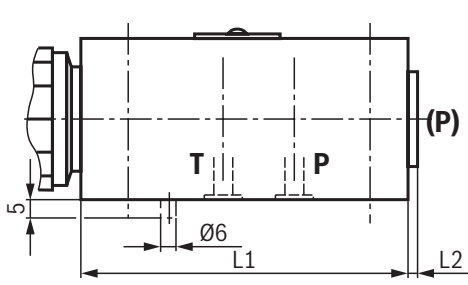

- 1 Adjustment type "S" (example)  
Grub screw with hexagon and protective cap
- 2 Name plate
- 3 4 valve mounting bores
- 4 Additional port (P), optional (e.g. for pressure measurement); not possible for NG10 and pressure rating >400 bar (= version "SO292"). Tightening torques (see table below)
- 5 Locking pin (only with type-examination tested safety valves)

NG	B1	B2	ØD3	H2	L1	L2	L3	L4	L5	L6	L18	(P)	Tightening torques $M_A$ in Nm <sup>2)</sup> Plug screw (4) <sup>1)</sup>	Weight, approx. in kg
6	45	60	6.6	40	80	4	15	55	40	20	15	G1/4	30	1.5
10	60	80	9	60	100	4	20	70	45	21	15	G1/2	80	3.7
20	70	100	9	70	135	5.5	20	100	65	34	15	G3/4	135	6.4
30	100	130	11	90	180	10	25	130	85	35	15	G1 1/4	480	13.9

**1) Different dimensions for version "/12"**

NG	(P)	Tightening torques $M_A$ in Nm <sup>2)</sup> Plug screw (4)
6	7/16"-20 UNF	18
10	3/4-16 UNF	70
20	1 5/16"-12 UN	170
30	1 7/8"-12 UN	320

2) The tightening torques are guidelines, referring to the maximum operating pressure and when using a manual torque wrench (tolerance  $\pm 10\%$ ).

For the **versions** and **dimensions** of the adjustment types refer to page 10 and 11.

**Valve mounting screws** (separate order)

Size	Quantity	Hexagon socket head cap screws	Material number
6	4	<b>ISO 4762 - M6 x 50 - 10.9-CM-Fe-ZnNi-5-Cn-T0-H-B</b> Friction coefficient $\mu_{total} = 0.09 \dots 0.14$ ; tightening torque $M_A = 12.5 \text{ Nm} \leq 10\%$	<b>R913048088</b>
10	4	<b>ISO 4762 - M8 x 70 - 10.9-FLZn/nc/480h/C</b> Tightening torque $M_A = 28 \text{ Nm} \leq 10\%$	<b>R913014548</b>
20	4	<b>ISO 4762 - M8 x 90 - 12.9-fLZn/nc/480h/C</b> Tightening torque $M_A = 28 \text{ Nm} \leq 10\%$	<b>R913069227</b>
30	4	<b>ISO 4762 - M10 x 110 - 12.9-fLZn/nc/480h/C</b> Tightening torque $M_A = 56 \text{ Nm} \leq 10\%$	<b>R913059433</b>

**Notice:**

- ▶ For reasons of stability, only the specified valve mounting screws are to be used.
- ▶ As replacements, you can use screws specified according to DIN 912.

**Dimensions:** Installation bore  
(dimensions in mm)

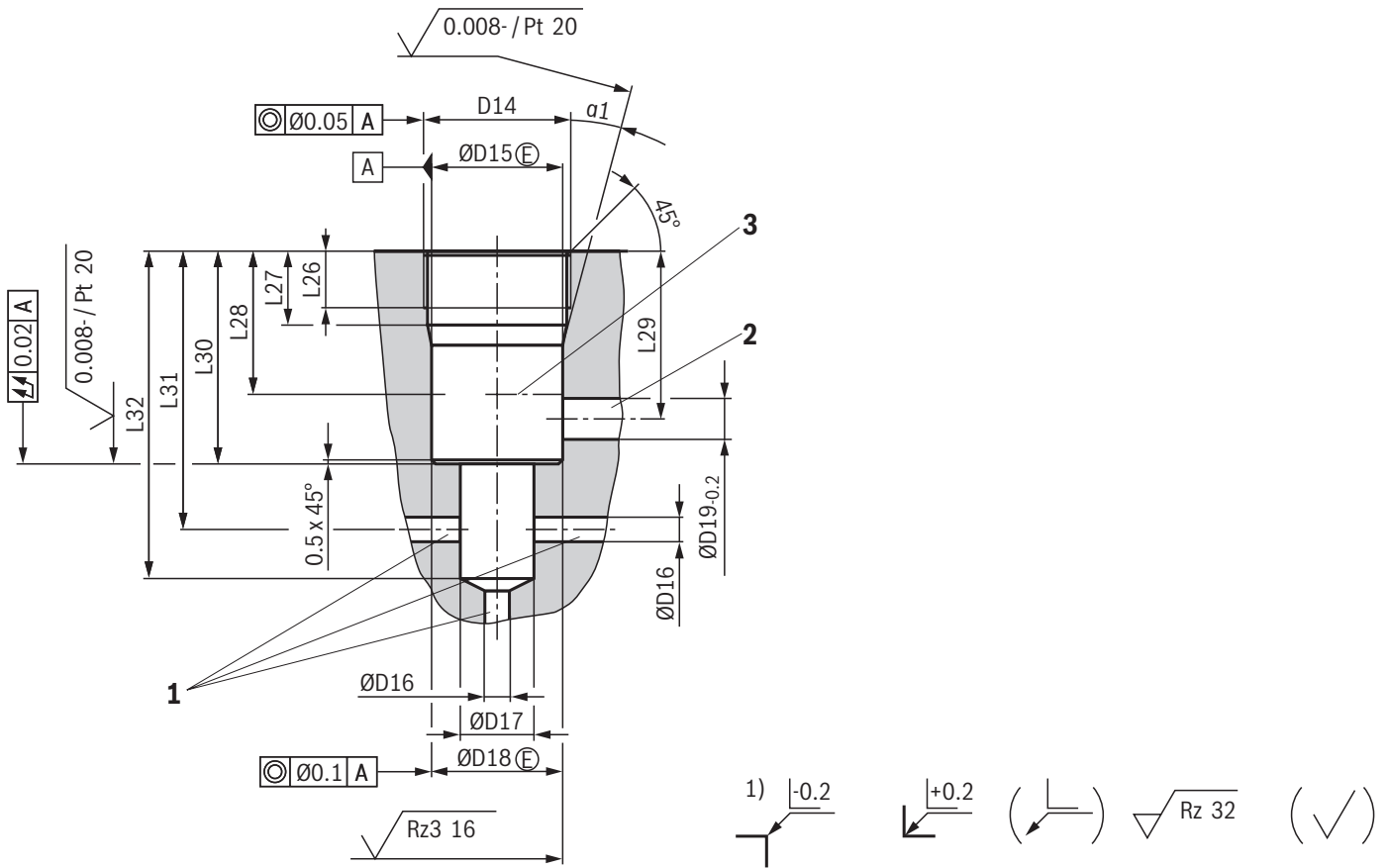

- 1 Port P, at any place at the circumference or at the front side
- 2 Port T, at any place at the circumference
- 3 Depth of fit

1) All seal ring insertion faces are rounded and free of burrs  
Tolerance for all angles ±0.5°

NG	D14	ØD15	ØD16	ØD17	ØD18	ØD19
6	M28 x 1.5	25H9	6	15	24.9 <sup>+0.152</sup> -0.2	12
10	M35 x 1.5	32H9	10	18.5	31.9 <sup>+0.162</sup> -0.2	15
20	M45 x 1.5	40H9	20	24	39.9 <sup>+0.162</sup> -0.2	22
30	M60 x 2	55H9	30	38.75	54.9 <sup>+0.174</sup> -0.2	34

NG	L26	L27	L28	L29	L30	L31	L32	α1
6	15	19	30	36	45	56.5±5.5	65	15°
10	18	23	35	41.5	52	67.5±7.5	80	15°
20	21	27	45	55	70	91.5±8.5	110	20°
30	23	29	45	63	84	113.5±11.5	140	20°

**Ordering code:** Type-examination tested safety valves, type "DBD...E," component series 1X according to Pressure Equipment Directive 2014/68/EU

NG	Designation	Component marking
6	DBD <input type="text"/> 1 <input type="text"/> 2 <input type="text"/> -1X/ <input type="text"/> <input type="text"/> <input type="text"/> <input type="text"/> <input type="text"/> 3 4 5 6 E	TÜV.SV.□-849.5.F.a <sub>w</sub> .p. TÜV.SV.□-849.5.F.G.p.
10	DBD <input type="text"/> 1 <input type="text"/> 2 <input type="text"/> -1X/ <input type="text"/> <input type="text"/> <input type="text"/> <input type="text"/> <input type="text"/> 3 4 5 6 E	TÜV.SV.□-850.6.F.a <sub>w</sub> .p. TÜV.SV.□-850.6.F.G.p. TÜV.SV.□-390.4,5.F.30.p. 1)
20	DBD <input type="text"/> 1 <input type="text"/> 2 <input type="text"/> -1X/ <input type="text"/> <input type="text"/> <input type="text"/> <input type="text"/> <input type="text"/> 3 4 5 6 E	TÜV.SV.□-361.10.F.a <sub>w</sub> .p.
30	DBD <input type="text"/> 1 <input type="text"/> 2 <input type="text"/> -1X/ <input type="text"/> <input type="text"/> <input type="text"/> <input type="text"/> <input type="text"/> 3 4 5 6 E	TÜV.SV.□-362.15.F.a <sub>w</sub> .p.

1) Component marking for DBD. 10.1X/...; 400 bar <  $p$  ≤ 630 bar

#### Adjustment type for pressure adjustment

1		NG6	NG10	NG20	NG30	
	Bushing with hexagon and protective cap	✓	✓	✓	✓	<b>S</b>
	Rotary knob	✓	✓	✓	-	<b>H</b>
	Hand wheel	-	-	-	✓	<b>H</b>

#### Type of connection

2		NG6	NG10	NG20	NG30	
	As screw-in cartridge valve (cartridge)	✓	✓	✓	✓	<b>K</b>
	For threaded connection	✓	✓	✓	✓	<b>G</b>
	For subplate mounting	✓	✓	✓	✓	<b>P</b>

#### Pressure rating <sup>1)</sup>

3	To be entered by the customer, e.g. pressure adjustment ≥ 30 bar and in 5 bar steps possible	<b>e.g. 150</b>
---	--	-----------------

#### Corrosion resistance (for availability see table below)

4	None	<b>no code</b>
	Improved corrosion protection (240 h salt spray test according to EN ISO 9227)	<b>J3</b>
	High corrosion protection (720 h salt spray test according to EN ISO 9227)	<b>J5</b>

#### Seal material (observe compatibility of seals with hydraulic fluid used, see page 6)

5	NBR seals	<b>no code</b>
	FKM seals	<b>V</b>

#### Line connection

6	Pipe thread according to ISO 228/1	<b>no code</b>
	Value entered at the factory	

1) When selecting the pressure rating, please observe the characteristic curves and notes on page 16.

#### Availability corrosion resistance (With type-examination procedure)

Type of connection	NG6	NG10	NG20	NG30
As screw-in cartridge valve "K"	no code, J5	no code, J5	no code, J5	no code, J5
For threaded connection "G"	no code, J3	no code, J3	no code, J3	no code, J3

**Deviating technical data:** Type-examination tested safety valves, version "DBD...E" according to Pressure Equipment Directive 2014/68/EU

<b>General</b>		
Ambient temperature range	°C	-10 ... +80
Conformity		CE according to Pressure Equipment Directive 2014/68/EU
<b>Hydraulic</b>		
Set response pressure	bar	See last figure of the component marking page 14
Maximum counter pressure in the discharge line	bar	See characteristic curves page 19 ... 23
Maximum flow	l/min	The last but one figure of the component marking attached at the safety valve is always binding, see page 14. For valve types which have a variable maximum flow depending on the response pressure, the discharge coefficient is specified at this place (see page 16).
Hydraulic fluid		Hydraulic fluids according to DIN 51524: Hydraulic oils HL and HLP are suitable for safety valves with NBR or FKM seals.
Hydraulic fluid temperature range (= TS)	°C	-10 ... +80
Viscosity range	mm <sup>2</sup> /s	12 ... 230

**Characteristic curves:** Type-examination tested safety valves, version "DBD...E" according to Pressure Equipment Directive 2014/68/EU

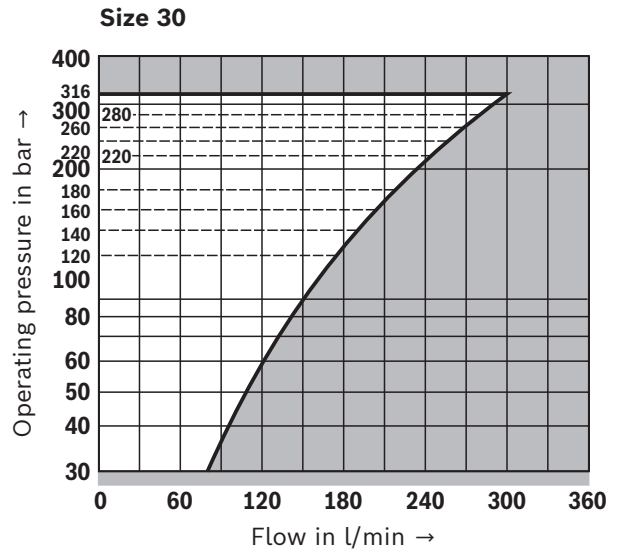
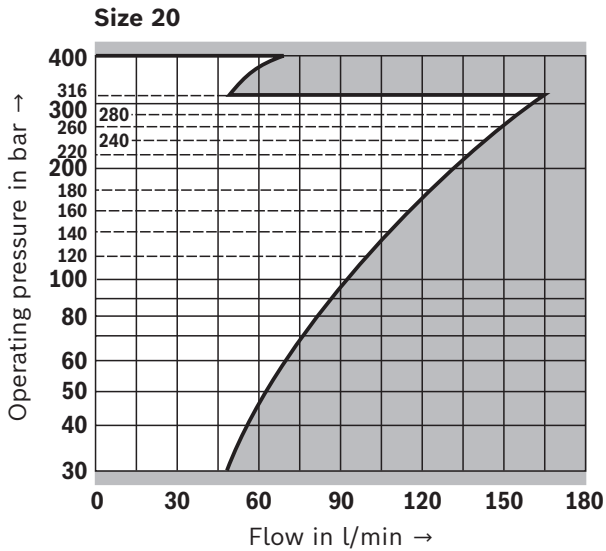
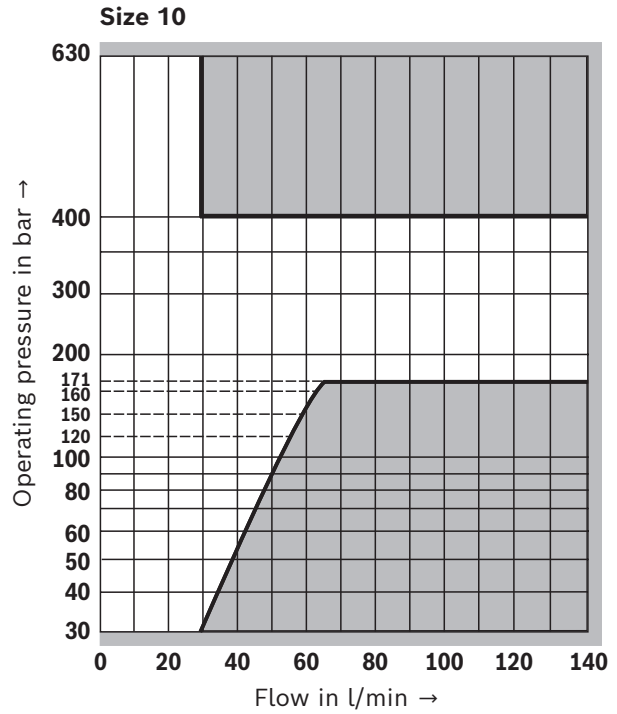
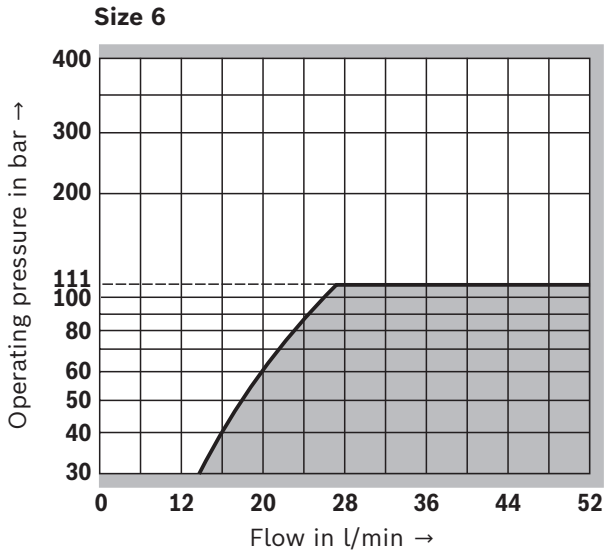

**Notice:**

Value pairs located in the areas of the characteristic curves with gray background cannot be realized with the safety valve. The characteristic curves shown here are only valid for a counter pressure of 0 bar in the discharge line.

**Deviating dimensions:** Screw-in cartridge valve as type-examination tested safety valve  
Version "DBD...E" according to Pressure Equipment Directive 2014/68/EU  
(dimensions in mm)

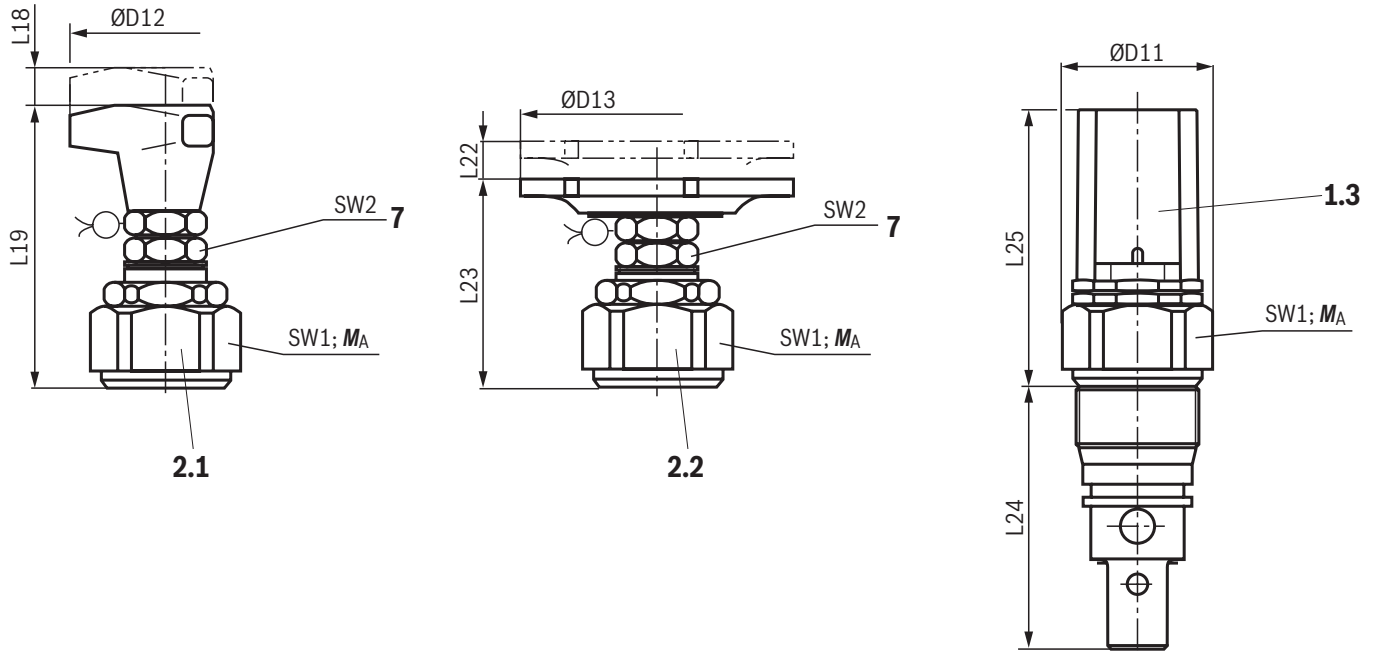

NG	ØD11	ØD12	ØD13	L18	L19	L22	L23	L24	L25
6	34	60	40	11	83	11	63	64.5	80
10	38	60	40	11	79	11	59	78.5	76.5
20	48	60	40	11	77	11	57	107	72.5
30	63	–	80	–	–	11	87	134	93

NG	SW1	SW2	Tightening torques $M_A$ in Nm for screw-in cartridge valves <sup>1)</sup>			Weight, approx. in kg
			Pressure rating in bar			
			up to 200	up to 400	up to 630	
6	32	19	50±5	80±5	–	0.4
10	36	19	100±5	150±10	200±10	0.5
20	46	19	150±10	300±15	–	1
30	60	19	350±20	500±30	–	2.2

- 1.3 Adjustment type "S" – hexagon with safety cap
- 2.1 Adjustment type "H" – rotary knob (see table below)
- 2.2 Adjustment type "H" – hand wheel (see table below)
- 7 Lock nut, tightening torque  $M_A = 10^{+5}$  Nm

<sup>1)</sup> The tightening torques are guidelines with a friction coefficient  $\mu_{total} = 0.12$  and when using a manual torque wrench.

**Adjustment type for corrosion resistance**

	NG6	NG10	NG20	NG30
Without corrosion protection	2.1	2.1	2.1	2.2
Version "J3" and "J5"	2.2	2.2	2.2	2.2

**Dimensions:** Sheet cut-out for front panel mounting for type-examination tested safety valves version "DBD...E" according to Pressure Equipment Directive 2014/68/EU (dimensions in mm)

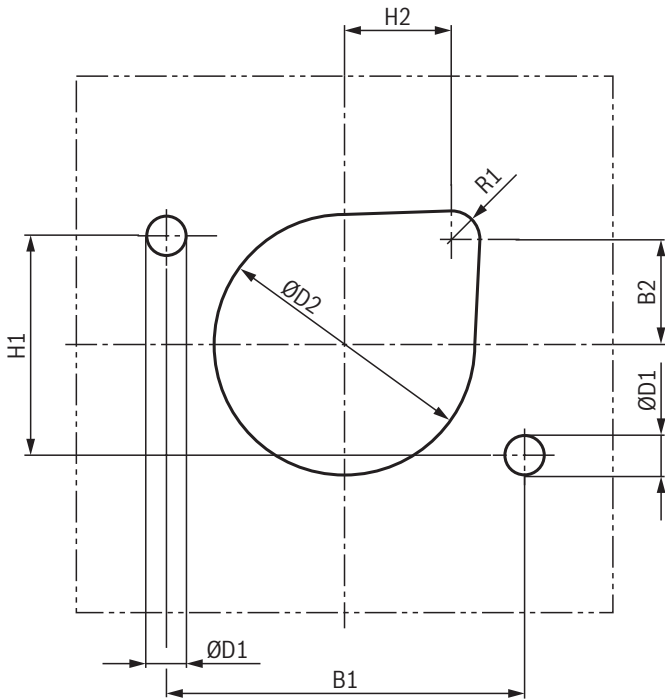

NG	B1	B2	H1	H2
6	45	12.5	25	22.5
10	60	20.5	40	20.5
20	70	24	50	24
30	100	29.5	60	29.5

NG	ØD1H13	ØD2H13	R1
6	7	40	8
10	9	44	8
20	9	55	8
30	11	73	8

**Notice:**

With valves type DBDH.K..1X/..E, the hand wheel must be removed before the front panel assembly of the screw-in cartridge valve and reinstalled afterwards.

## Safety instructions: Type-examination tested safety valves, version "DBD...E" according to Pressure Equipment Directive 2014/68/EU

- ▶ Before ordering a type-examination tested safety valve, it must be observed that for the desired **response pressure  $p$** , the maximum admissible **flow  $q_{Vmax}$**  of the safety valve must be larger than the maximum possible flow of the system/accumulator to be secured.
- ▶ According to the **Pressure Equipment Directive 2014/68/EU**, the increase in the system pressure due to the flow must not exceed 10% of the set response pressure (see component marking page 14).
- ▶ The maximum admissible flow  **$q_{Vmax}$**  stated in the component marking must not be exceeded.
- ▶ Discharge lines of safety valves must end in a risk-free manner. It must not be possible for fluids to accumulate in the discharge system (see data sheet AD2000 A2).



### Application notes must always be observed

- ▶ In the plant, the response pressure specified in the component marking is set at a flow of 2 l/min.
- ▶ The maximum flow stated in the component marking applies for applications without counter pressure in the discharge line (port T).
- ▶ Removal of the lead seal at the safety valve renders the approval according to the Pressure Equipment Directive void!
- ▶ The requirements of the Pressure Equipment Directive and of data sheet AD 2000 A 2 generally have to be observed.
- ▶ It is recommended to secure type-examination tested safety valves against inadmissible disassembly by means of wiring and sealing with the housing/block (bore available in the adjustment type).



### Notice:

The system pressure increases by the counter pressure in the discharge line (port T) due to the increasing flow. (Observe the data sheet AD 2000 A 2, point 6.3).  
To ensure that this increase in system pressure caused by the flow does not exceed the value of 10% of the set response pressure, the admissible flow has to be reduced dependent on the counter pressure in the discharge line (port T) (see characteristic curves page 19 ... 23).

## Characteristic curves: Counter pressure in the discharge line

In principle, the valve should be operated without counter pressure in the discharge line, if possible. In case of counter pressure in the discharge line, the maximum possible flow is reduced. There is a relationship between maximum counter pressure  $p_T$  in the discharge line and flow  $q_V$ , which can be seen from the following characteristic curve. Characteristic curves for intermediate values of the response pressure which are not listed must be determined by means of interpolation.  
When the flow approaches zero, the maximum counter pressure  $p_T$  is in each case 10% of the response pressure. As the flow increases, the maximum counter pressure  $p_T$  decreases.

### Interpolation of intermediate values from the diagram

1. At the axis  $p_T$ , mark 1/10 of the value of  $p_A$ .
2. Determine the next lower and the next higher characteristic curve for this point. The point marked at  $p_T$  divides the section between lower and higher characteristic curve on the  $p_T$  axis with a certain percentage.
3. At the  $q_{Vmax}$  axis, divide the section between the next lower and next higher characteristic curve in the same percentage as the section at the  $p_T$  axis. From the zero position flow on the  $q_{Vmax}$  axis determined in that way, draw a straight line to the value on the  $p_T$  axis marked before.
4. Mark the system flow to be secured at the  $q_{Vmax}$  axis.
5. Read the maximum counter pressure for this value using the line at the  $p_T$  axis drawn before.

### Characteristic curves: Counter pressure in the discharge line – size 6

Maximum counter pressure  $p_T$  in the discharge line (port T) as a function of the flow  $q_V$  with different response pressures  $p_A$ .

Version "DBD 6 ...E"

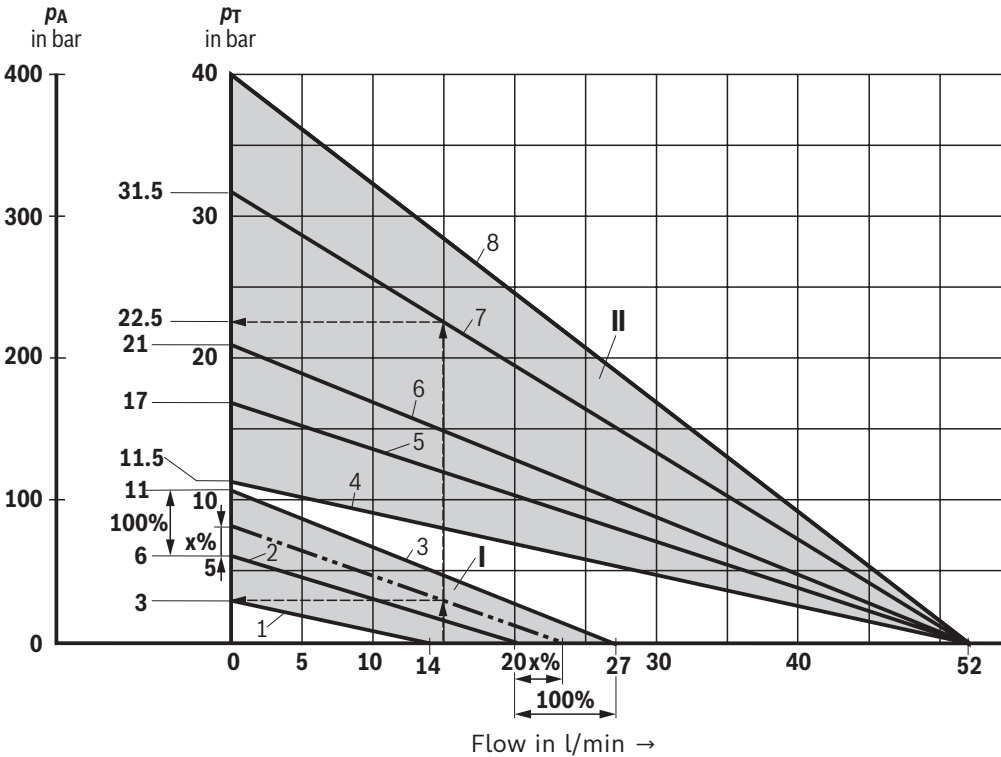

Characteristic curves	Response pressure $p_A$ in bar
1	30
2	60
3	110
4	115
5	170
6	210
7	315
8	400

Characteristic curves for intermediate values can be generated by interpolation. Further explanations can be found on page 19.

- $p_A$  Response pressure in bar
- $p_T$  Maximum counter pressure in the discharge line (port T) in bar
- $q_{Vmax}$  Maximum flow in l/min
- I Interpolation area I, for valves with  $p_A = 30 \dots 110$  bar and  $q_{Vmax} = 14 \dots 27$  l/min
- II Interpolation area II, for valves with  $p_A = 115 \dots 400$  bar and  $q_{Vmax} = 52$  l/min

#### Determination of the maximum counter pressure

##### Example 1 (with already existing characteristic curve):

Flow of the system/accumulator to be secured:

$q_{Vmax} = 15$  l/min

Safety valve set to:  $p_A = 315$  bar.

Read the maximum counter pressure  $p_T$  of approx. 22.5 bar from the diagram (see arrows, characteristic curve 7).

##### Example 2 (with interpolated characteristic curve):

Flow of the system/accumulator to be secured:

$q_{Vmax} = 15$  l/min

Safety valve set to:  $p_A = 80$  bar.

Value to be marked at the axis referred to as  $p_T$ :

$1/10 \times 80$  bar = 8 bar.

Read the maximum counter pressure  $p_T$  of approx. 3 bar from the diagram (see arrows, dashed characteristic curve).

### Characteristic curves: Counter pressure in the discharge line – size 10

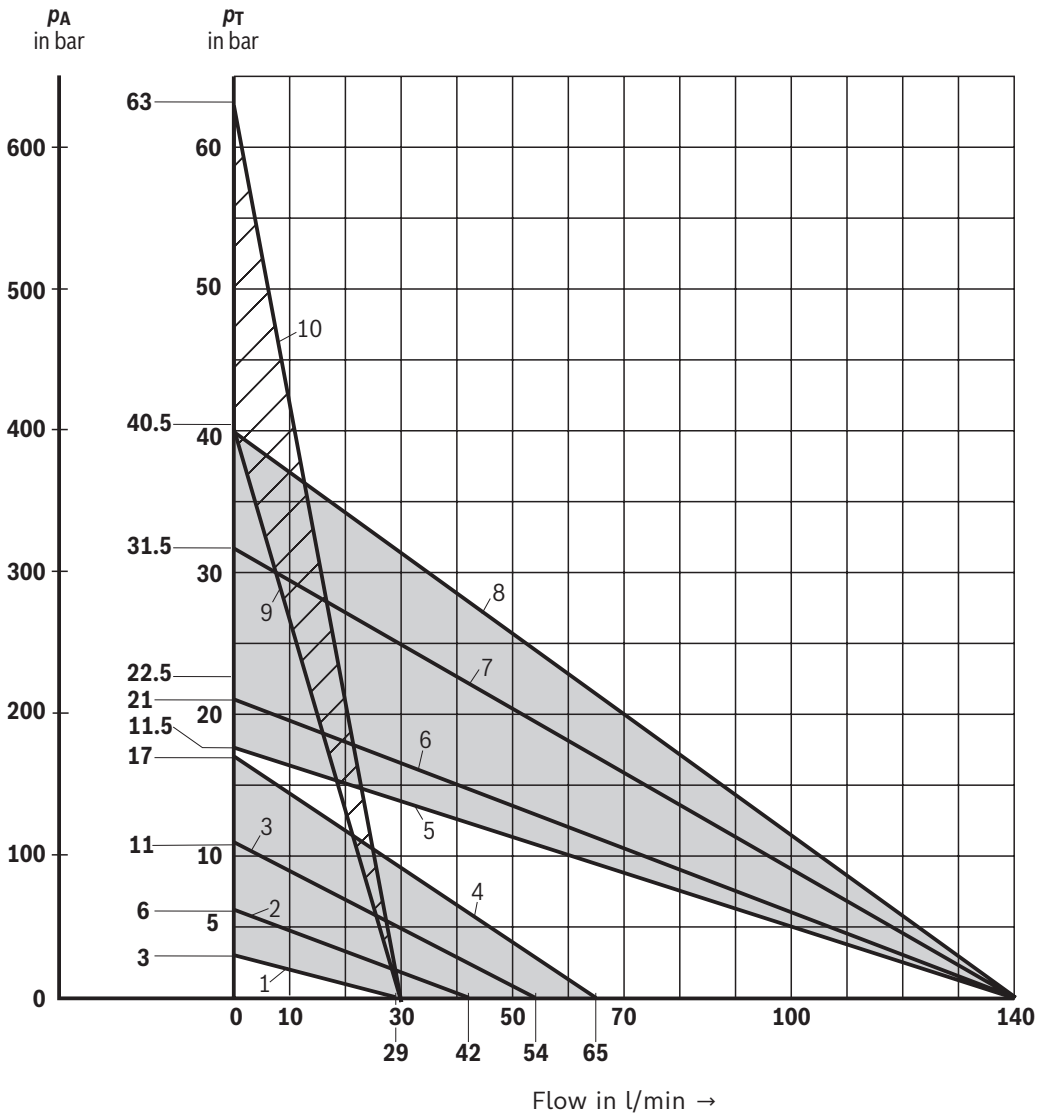

Maximum counter pressure  $p_T$  in the discharge line (port T) as a function of the flow  $q_V$  with different response pressures  $p_A$ .

Version "DBD 10 ...E"



Characteristic curves	Response pressure $p_A$ in bar
1	30
2	60
3	110
4	170
5	175
6	210
7	315
8	400
9	405
10	630

Characteristic curves for intermediate values can be generated by interpolation. Further explanations can be found on page 19.

- $p_A$  Response pressure in bar
- $p_T$  Maximum counter pressure in the discharge line (port T) in bar
- $q_{Vmax}$  Maximum flow in l/min
-  Interpolation areas
- 

### Characteristic curves: Counter pressure in the discharge line – size 20

Maximum counter pressure  $p_T$  in the discharge line (port T) as a function of the flow  $q_V$  with different response pressures  $p_A$ .

Version "DBD 20 ...E"

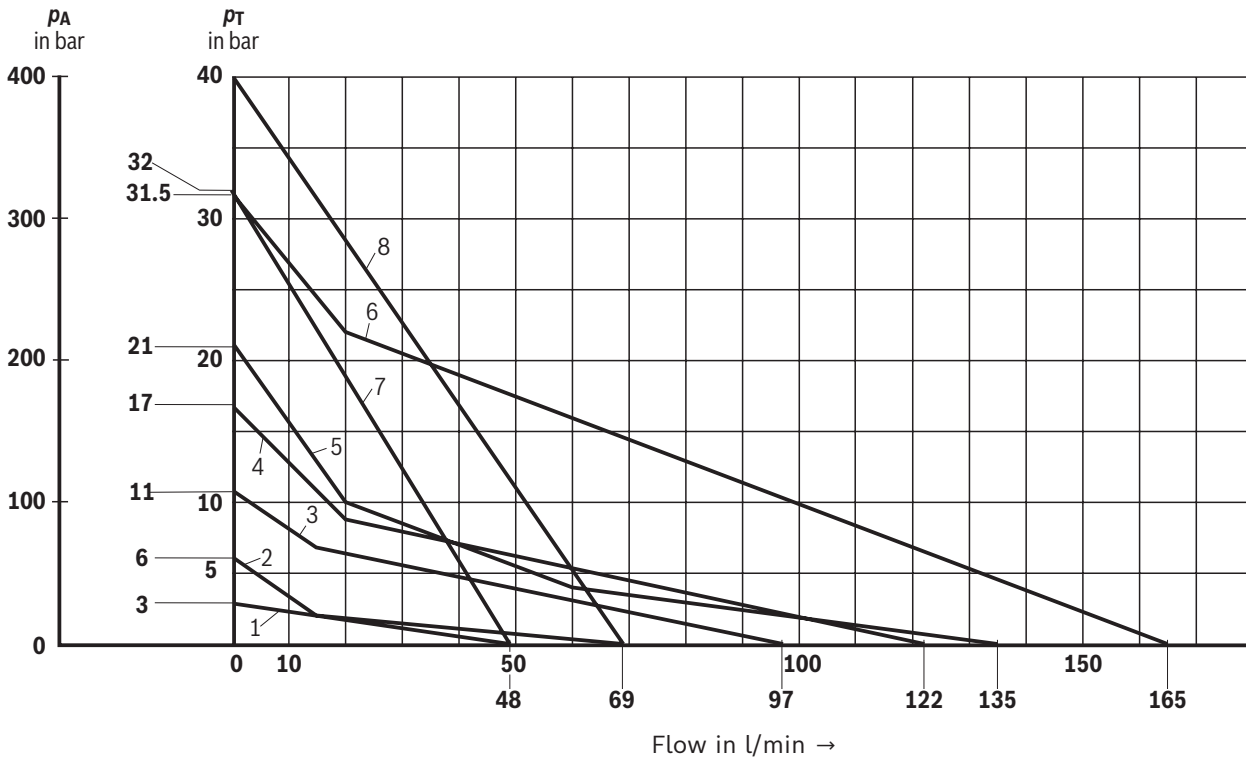

- $p_A$  Response pressure in bar
- $p_T$  Maximum counter pressure in the discharge line (port T) in bar
- $q_{Vmax}$  Maximum flow in l/min

Characteristic curves	Response pressure $p_A$ in bar
1	30
2	60
3	110
4	170
5	210
6	315
7	320
8	400

Characteristic curves for intermediate values can be generated by interpolation. Further explanations can be found on page 19.

### Characteristic curves: Counter pressure in the discharge line – size 30

Maximum counter pressure  $p_T$  in the discharge line (port T) as a function of the flow  $q_v$  with different response pressures  $p_A$ .

Version "DBD 30 ...E"

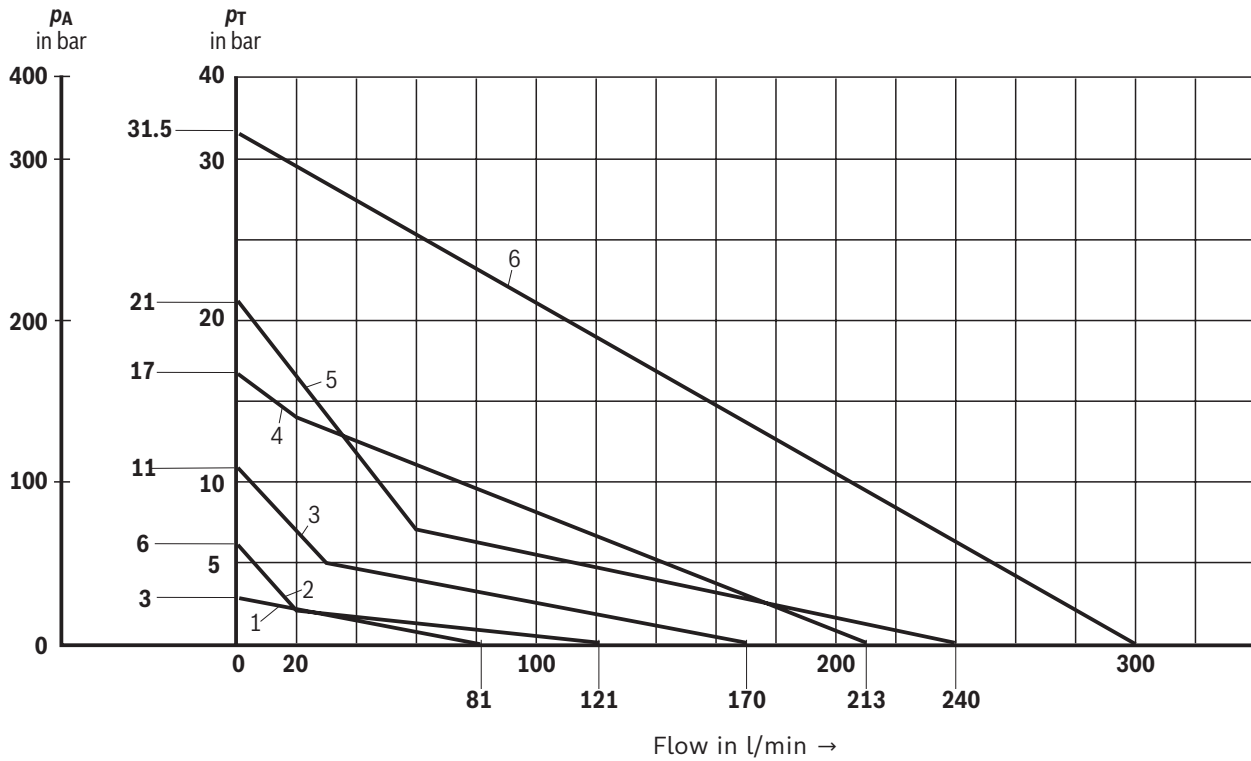

- $p_A$  Response pressure in bar
- $p_T$  Maximum counter pressure in the discharge line (port T) in bar
- $q_{vmax}$  Maximum flow in l/min

Characteristic curves	Response pressure $p_A$ in bar
1	30
2	60
3	110
4	170
5	210
6	315

Characteristic curves for intermediate values can be generated by interpolation. Further explanations can be found on page 19.

## Further information

- ▶ Safety equipment against excessive pressure – safety valves
  - ▶ Subplates
  - ▶ Hydraulic fluids on mineral oil basis
  - ▶ Environmentally compatible hydraulic fluids
  - ▶ Flame-resistant, water-free hydraulic fluids
  - ▶ Flame-resistant hydraulic fluids – containing water (HFAE, HFAS, HFB, HFC)
  - ▶ Reliability characteristics according to EN ISO 13849
  - ▶ Use of non-electrical hydraulic components in an explosive environment (ATEX)
  - ▶ Hydraulic valves for industrial applications
  - ▶ Pressure relief valve, pilot-operated
- Data sheet AD 2000 A 2  
Data sheet 45100  
Data sheet 90220  
Data sheet 90221  
Data sheet 90222  
Data sheet 90223  
Data sheet 08012  
Data sheet 07011  
Operating instructions 07600-B  
Operating instructions 25802-B

Bosch Rexroth AG  
Industrial Hydraulics  
Zum Eisengießer 1  
97816 Lohr am Main, Germany  
Phone +49 (0) 93 52/40 30 20  
my.support@boschrexroth.com  
www.boschrexroth.com

Evolution Motion Solutions 13835  
Senlac Dr, Farmers Branch, TX 75234  
800-569-9801  
info@evolutionmotion.com  
www.evolutionmotion.com

© All rights reserved to Bosch Rexroth AG, also regarding any disposal, exploitation, reproduction, editing, distribution, as well as in the event of applications for industrial property rights.  
The data specified above only serve to describe the product. As our products are constantly being further developed, no statements concerning a certain condition or suitability for a certain application can be derived from our information. The information given does not release the user from the obligation of own judgment and verification. It must be remembered that our products are subject to a natural process of wear and aging.