



Modular belt conveyor

VarioFlow belt

1/8

BOOST YOUR PRODUCTION

Higher flexibility and more efficient realization of transport solutions for sensitive products.



SAFE TRANSPORT AND UNRESTRICTED SECTION PLANNING

Experience maximum reliability and flexibility when transporting unstable and sensitive products. Our new VarioFlow *belt* modular belt conveyor combines the smooth running characteristics and safety of a fine-meshed conveyor belt with the modular design of a chain conveyor system. This allows faster, safer and more versatile transport of bulk and film-wrapped products as well as oversize packages.



SAFER TRANSPORT

Smooth material flow of packaged fast moving consumer goods.

VarioFlow belt adapts to your requirements and ensures that your products are safely transported, distributed and joined.



VARIABLE IN USE

Thanks to its very close-meshed and flat surface, the VarioFlow *belt* modular belt conveyor is suitable for a variety of applications. The special features of the system offer numerous benefits:



VarioFlow *belt* is suitable for direct transport of deep-drawn plastic trays with delicate support surfaces.



The special surface structure of the modular belts minimizes the risk of film-wrapped products getting caught in the conveyor medium or even damaged.



The large surface area of the belt allows unstable products such as packages filled with kitchen towel rolls or toilet paper to lie completely flat during transport.



Different sizes and types of secondary and tertiary packaging are also transported gently and reliably with the system.

YOUR BENEFITS

Proven system design with new conveyor medium.

Our new modular belt variant VarioFlow *belt* extends our successful VarioFlow modular conveyor system. The product-friendly belt design offers decisive benefits.



Curving on both sides

Flexible layout design with only one belt type.



Long sections

Up to 30 meters with only one drive.

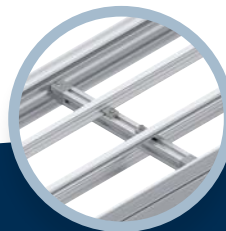

Scalable cross connectors

System widths deviating from the standard can be easily realized.

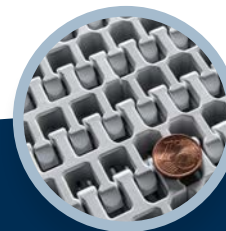

Fine-meshed transport surface

Reliable, smooth transport even of sensitive products.

VarioFlow *belt* includes modular belts in standard widths of 406 and 608 mm. Scalable cross connectors based on aluminum profiles make it possible for integrators to also implement customized belt widths using identical system components. The modular belt conveyor system allows conveyor lengths of up to 30 m, layouts with curves on both sides and conveyor speeds of up to 40 m/min to be realized with one drive.

Bosch Rexroth offers all system components for complete VarioFlow *belt* conveyors from a single source. The standardized modular system enables short delivery times and rapid project implementation.

Smart system design

Assembly of conveyor sections requires fewer sliding rails compared to market solutions. The sliding rails are mounted from the side without the use of rivets. This eliminates the need to machine the running surface. This makes VarioFlow *belt* extremely smooth and low-wear.



Small deflection radius

This reduces conveyor trenches and rarely requires additional bridging components.



Large selection of product guides

Optimum adaptation to the conveyed material due to a variety of combination options.



Bosch Rexroth Store

Further details, technical data and product specifications can be found online at the Rexroth Store.

YOUR PLANNING



Easy planning and design with the Planning software MTpro

With the free Engineering Software **MTpro** and the browser-supported **MTpro Online Designer**, Bosch Rexroth offers comprehensive design support.

This allows designers to "make headway with their sections" and validate the created layouts in no time at all.

In addition to quick planning, users benefit from automatic order list generation, the simple exchanging or printing of layout data and direct transfer to the Rexroth Online Shop or a partner company.



More information and downloads for MTpro can be found here:
<https://www.boschrexroth-us.com/mtpro>

QUICK CONFIGURATION AND DESIGN WITH MTPRO

MTPro, the free and intuitive software for planning assembly systems, supports users from selection and configuration through to ordering of Rexroth products. MTPro enables users to plan, calculate and document their modular belt conveyor in just a few steps. The Layout Designer enables even the most complex constructions and system layouts to be created in no time at all.

System integrators and planners simply select the components from the range using drag and drop and then assemble them virtually using the snap function. An integrated evaluation function for the individual

configuration eliminates the need for a third party to check the design and further reduces the engineering times.

The system outputs parts lists directly, and users who are registered in the Rexroth Store will also see the prices. Automatic parts list costing with electronic order links minimizes administrative work. The planning data can be reused in other programs for design, purchasing and service.



PRODUCT OVERVIEW

Customized basic modules – identical system components

Thanks to the comprehensive VarioFlow modular system, you benefit from a reliable, standardized and versatile conveyor system. The universally usable components are suitable for all system widths, which reduces the part variance. The fine-meshed modular belt is available in different versions for horizontal and vertical transport of different products and trays.

The system enables chain tensile forces of up to 1250 N. These allow conveyor lengths of up to 30 m, layouts with curves on both sides and conveyor speeds of up to 40 m/min to be realized with one drive. A wide range of standard system components for product guides, leg sets and drive kits from Bosch Rexroth enables the design-free implementation of individual sections from a single source.

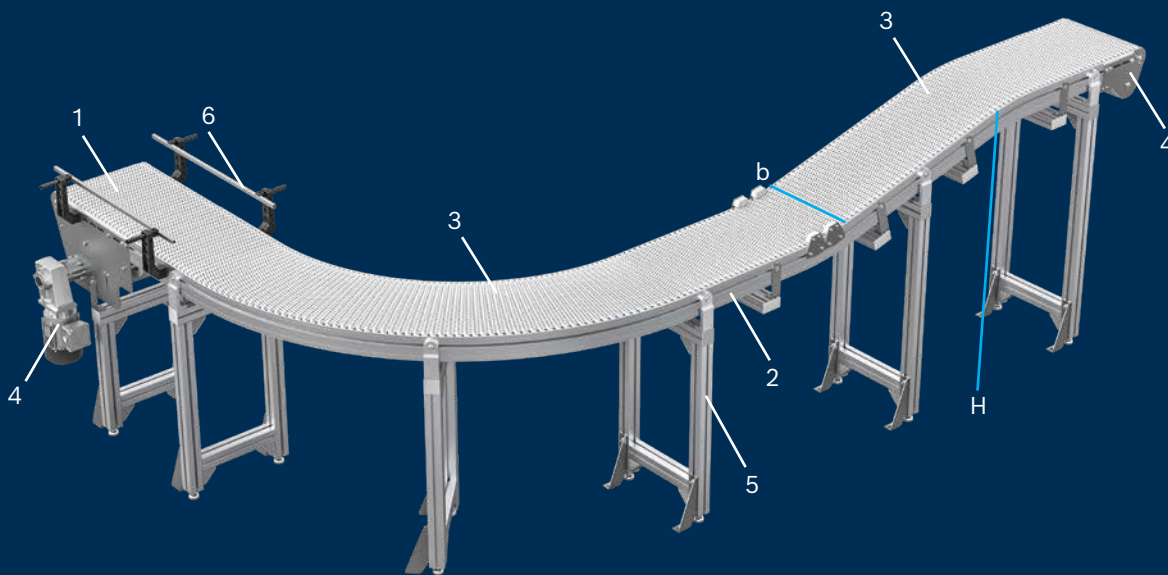

- 1 Modular belt
- 2 Section elements
- 3 Curves
- Drive and return unit
- 5 Leg sets
- 6 Product guide



System dimensions

Conveyor height H

The conveyor height indicates the distance from the leveling foot to the surface of the flat modular belt.

Track width b



The track width characterizes the distance between the outer surfaces of the section profiles.

<p>Modular belts</p>  <p>▶ 12</p>	<p>Section elements</p>  <p>▶ 14</p>	<p>Curves</p>  <p>▶ 24</p>
---	--	---

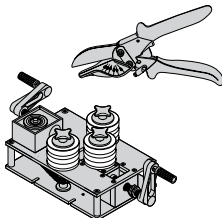
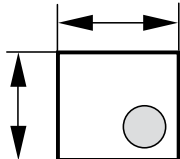
<p>Drive and return unit</p>  <p>▶ 30</p>	<p>Leg sets</p>  <p>▶ 38</p>	<p>Product guide</p>  <p>▶ 42</p>
---	--	--

<p>Tools</p>  <p>▶ 54</p>	<p>Technical data</p>  <p>▶ 56</p>
---	--

Legend

-  Delivery quantity
-  Minimum order quantity

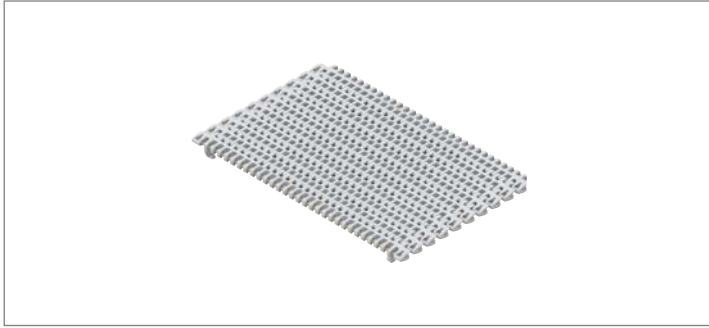

Modular belts

The modular belts are assembled in a brick bond, in which the modules interlock to give the belt special lateral strength. The narrow-meshed belt surface also ensures low-vibration transport of small parts.

The use of the complete modular belt surface is possible, since on the underside, the belt is equipped with integrated holding-down clamps. As a result, even overwide products can be transported on a horizontal section path.

- ▶ Curving on both sides
- ▶ Maximum permissible belt tensile force: 1250 N
- ▶ Materials meet the requirements of EU 10/2011 and FDA CFR 21

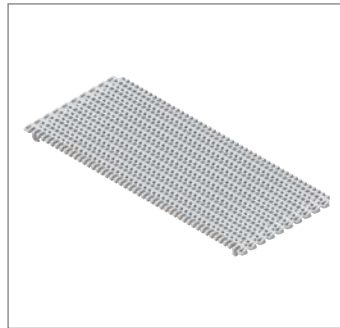

Flat modular belts

The flat modular belt is used for direct transport of products or for indirect transport via customer-owned workpiece pallets / trays.

- ▶ Transport on ascending or descending sections up to about $5\pm 2^\circ$ possible, depending on the product (test required)
- ▶ Accumulation operation permitted, depending on the product

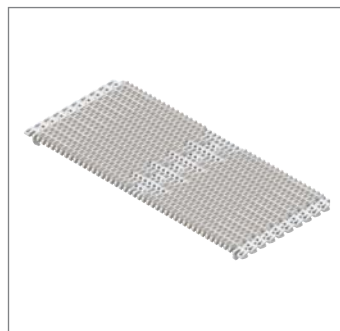
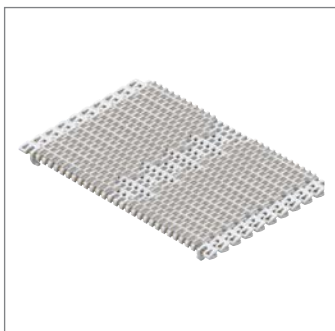

Static friction modular belts

The static friction modular belt is used for transporting products on ascending or descending sections.

All module members are provided with a static friction lining, the grip of which is maintained by regular cleaning. The lining-free edge and central zone of the surface serves to guide the modular belt. The lining is not suitable for transporting sharp-edged objects.

- ▶ Transport on ascending or descending sections up to about 15° possible. Maximum gradient subject to conveyed material properties
- ▶ Accumulation operation not permitted
- ▶ Only suitable for dry operation
- ▶ Do not use static friction coating in direct contact with fatty food

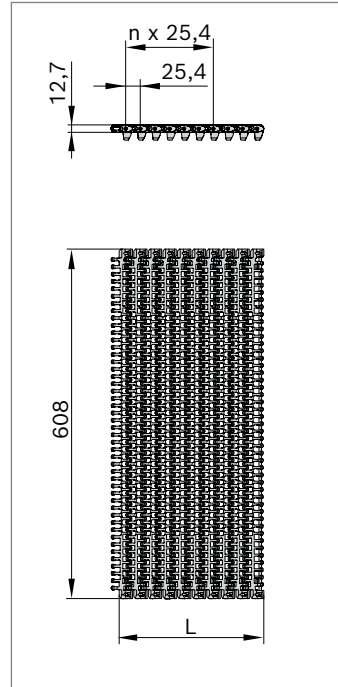
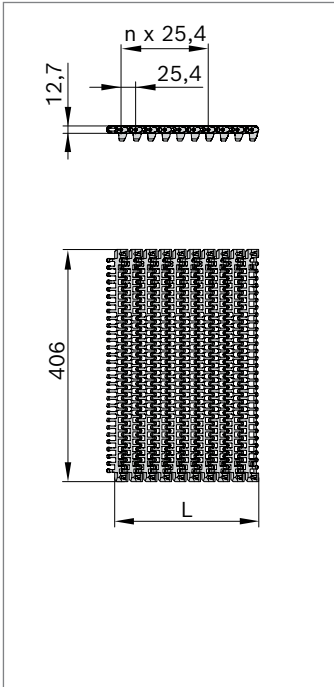

Flat modular belt	b	L (mm)	☒	No.
406	420	2997	1	3842572097
608	622	1981	1	3842572098

Material: Belt element: POM; hinge rod: PA

Scope of delivery: Complete, incl. hinge rod

Condition on delivery: Fully assembled

Additional versions are available on request from our modification department (COS@boschrexroth.de).

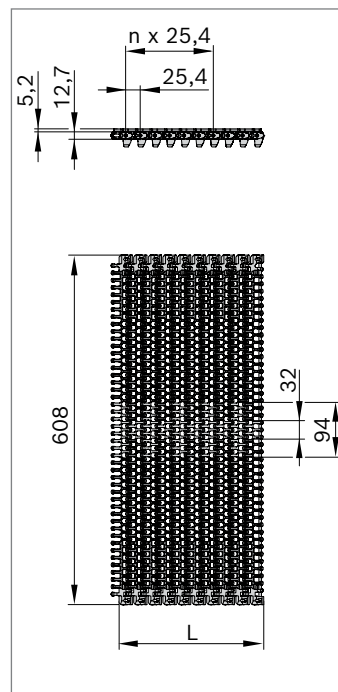
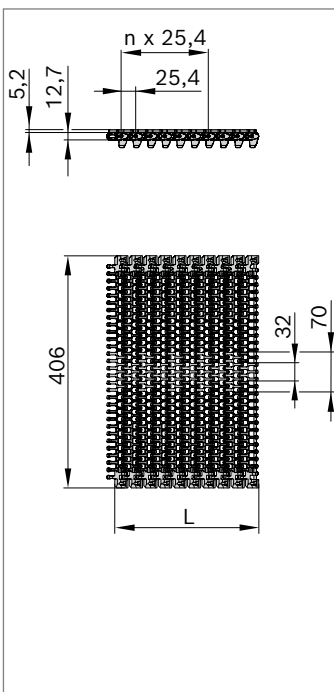

Static friction Modular belt	b	L (mm)	☒	No.
406	420	2997	1	3842572099
608	622	1981	1	3842572100

Material: Belt element: PP; static friction coating: TPE; hinge rod: PA

Scope of delivery: Complete, incl. hinge rod

Condition on delivery: Fully assembled

Additional versions are available on request from our modification department (COS@boschrexroth.de).

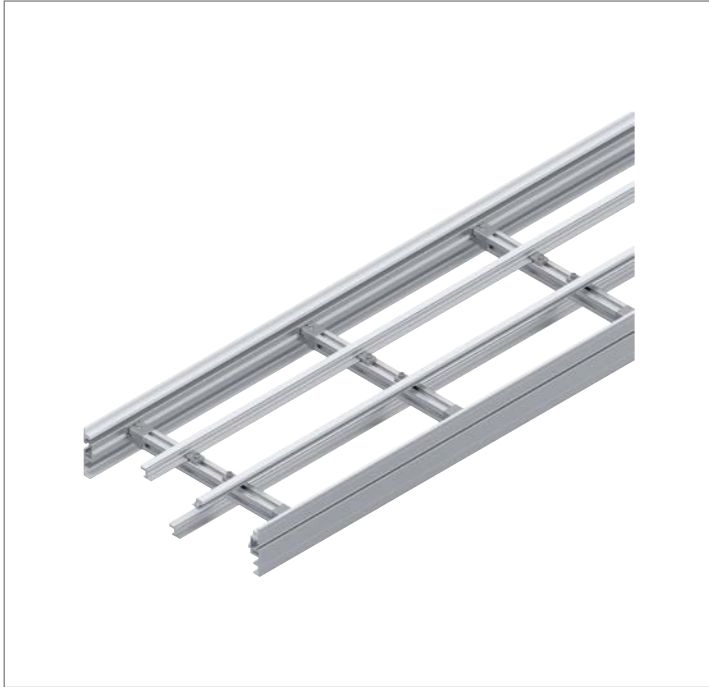

Section elements

To build a conveyor section, two open section profiles are required, which are connected by cross connectors. Two clamping heads are screwed together with a 30x30 strut profile to form a cross connector. The track width is determined by the use of strut profiles of different lengths. In order to support the modular belt in the upper and lower run, the support profile is fastened to the existing cross connectors with the aid of the clamping pieces.

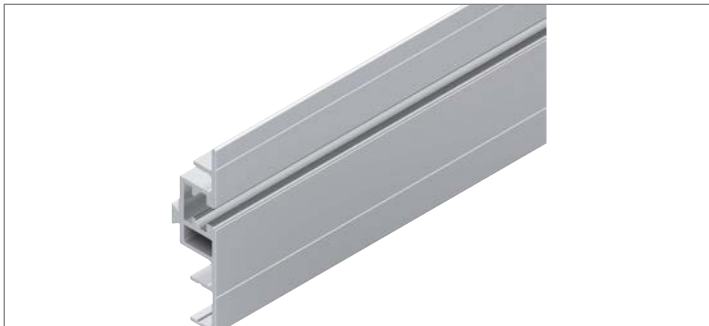

Section profile VFbelt AL

The section profile is the supporting element for the construction of straight conveyor sections and allows for the attachment of all required components. The open construction of the section profile allows dirt or foreign particles to be removed directly.

- ▶ Same profile cross-section across all sizes
- ▶ Slot on the inside for attaching main components such as drive/return unit, curves, etc.
- ▶ A 10 mm outside slot for simple fastening of lateral guides, leg sets, or other accessories
- ▶ If required, lateral mounting of the sliding rail with centering groove as drill guide
- ▶ Special constructions can be attached quickly and simply with components from the modular aluminum framing system through the 10 mm outside slot.

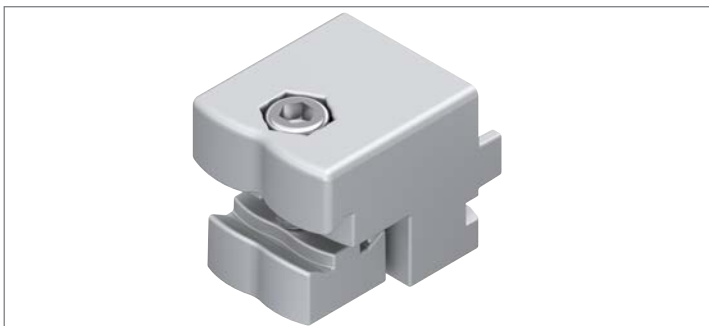

Clamping head VFbelt

Two section profile halves are connected to the clamping heads of the cross connector to form an open conveyor section. The system width b is determined by the length L of the 30x30 strut profile contained in the cross connector.

System width b (mm)	Length L (mm)
420	306
622	508
b	$b - 114$

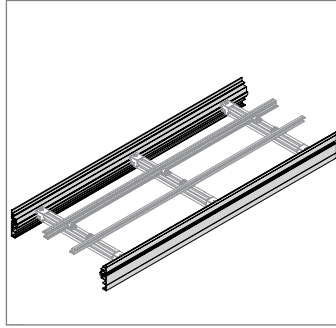
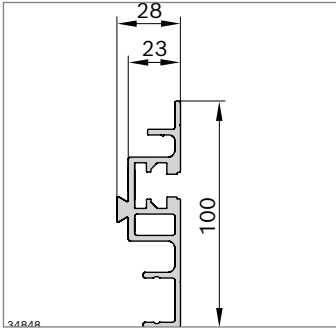

Section profile	L (mm)	No.
VFbelt AL		
1 pc	50 ... 6000	3842997022/L
 16 pcs	6170	3842572101

Material: Aluminum; natural, anodized

Accessories, required:

- ▶ Profile connector (page 20)
- ▶ Clamping head (page 15)
- ▶ Sliding rail, L and C-shaped (page 19)
- ▶ Support profile (page 17)

Accessories, recommended:

- ▶ Cover profile (page 21)
- ▶ Flange nut (page 22)
- ▶ T-bolt (page 22)
- ▶ Collar screw (page 23)
- ▶ T-nut (page 23)

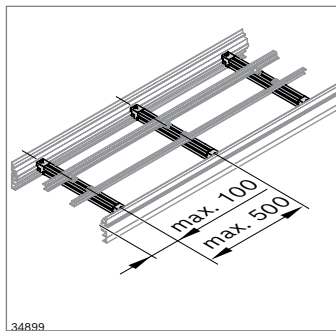
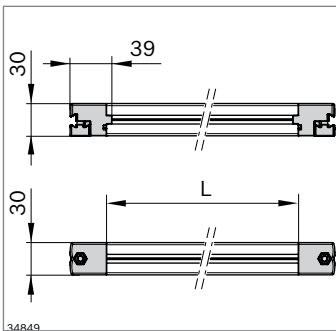

Clamping head		No.
VFbelt		
	20	3842572105

Material: Diecast aluminum

Accessories, required:

- ▶ Central bolt S8x25 (2x) (3842527174)
- ▶ Strut profile 30x30 (3842990720/L)



Support profile VFbelt AL

The main task of the support profile onto which the L-shaped sliding rail is clipped is to provide a running surface with the lowest possible friction and to reduce the wear of the modular belt. The system width determines the necessary number of support profiles. In the upper run, the support profile projects by 490 mm into the drive and by 197 mm into the return unit and must be designed accordingly longer.

In the lower run, the support profile should be about 10 – 20 mm shorter than the section profile.

- ▶ The support profile is fastened to the cross connectors with the clamping piece
- ▶ If required, lateral mounting of the sliding rail with centering groove as drill guide



Clamping piece VFbelt

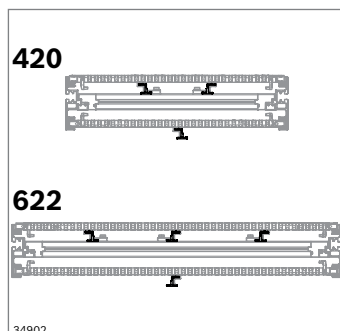
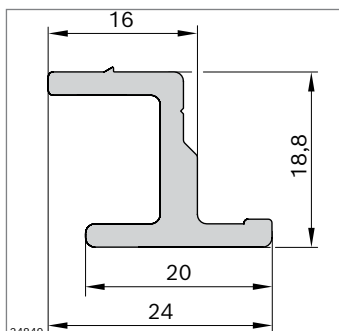

Support profile VFBelt AL	L (mm)	No.
1 pc	50 ... 3000	3842997023
 12 pcs	3000	3842572102

Material: Aluminum; natural, anodized

Accessories, required:

- ▶ Clamping piece (page 17)
- ▶ Sliding rail, L-shaped (page 19)

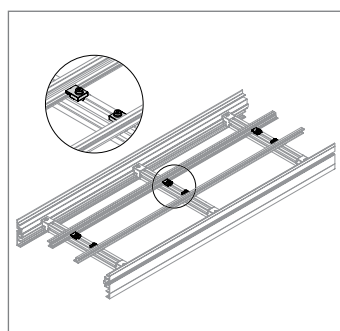
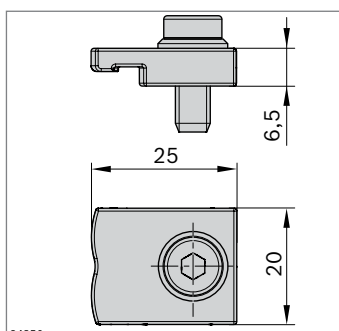

Clamping piece VFBelt		No.
	50	3842572107

Material: Diecast aluminum

Accessories, required:

- ▶ For assembly on cross connector: T-nut 8, M6 (galvanized steel) (3842501753)
- ▶ For installation on support strut in vertical curve: T-nut 10, M6 (galvanized steel) (3842530285)

Notice: Not required when using holder 3842572106.



Sliding rails

Sliding rails guide and support the modular belt. Extend the sliding rails over the component interfaces to ensure minimum wear and noise emissions. Interruptions to the profile or component connections must be avoided. If an interruption is necessary after 10 m, the sliding rails must be attached laterally with a sheet metal screw.

Notice: After the sliding curves, an interruption is provided as an expansion joint in the inner curve area.

- ▶ Secured against axial shifting with lateral screw fittings
- ▶ Lateral securing means the sliding surface does not need to be machined and abrasion and noise level are reduced
- ▶ Materials meet the requirements of EU 10/2011 and FDA CFR 21



Sliding rail VFbelt C-shaped

The C-shaped sliding rail is clipped into the section profile.



Sliding rail VFbelt L-shaped

The L-shaped sliding rail is clipped onto the section and support profile.

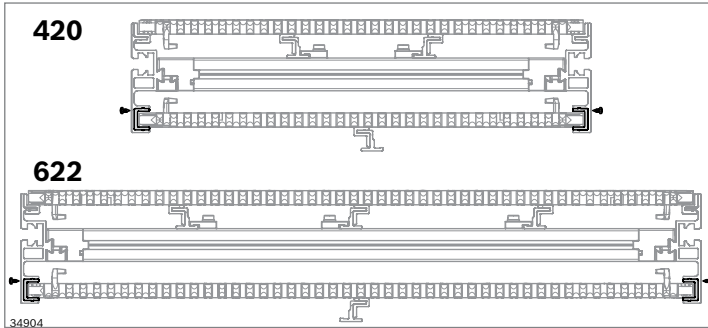



Sliding rail VFbelt C-shaped	L (mm)		No.
	30000	1	3842572104

Material: PE

Accessories, required:

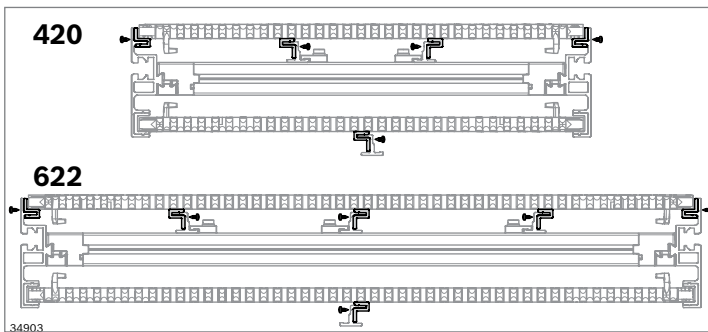
- ▶ Oval-head screw (page 20)



Sliding rail VFbelt L-shaped	L (mm)		No.
	30000	1	3842572103

Material: PE

Accessories, required:

- ▶ Oval-head screw (page 20)



Screw set VFbelt

The oval-head screw 2.9x6.5 is used to secure the sliding rails laterally in order to avoid displacement along the section profile.

Reduction of abrasion and noise level by lateral fixing of the sliding rails, without machining of the track bearing surfaces. Each sliding rail section must be secured with one screw at a time.

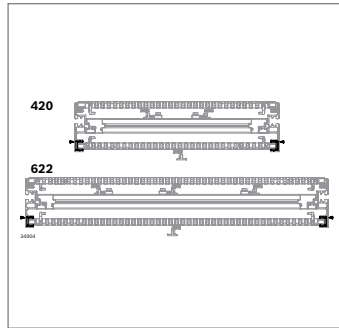
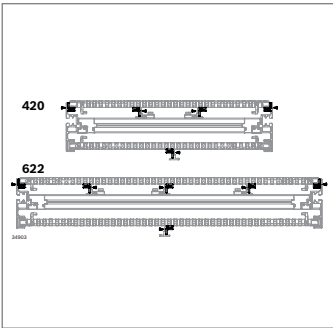

Screw set VFbelt		No.
	100	3842572167

Material: Non-rusting steel



Profile connector AL

Profile connectors are used to connect the end faces of the section profiles. The profile connector is fixed in the interior slot, so that the slot on the outside is available for all kinds of superstructures.

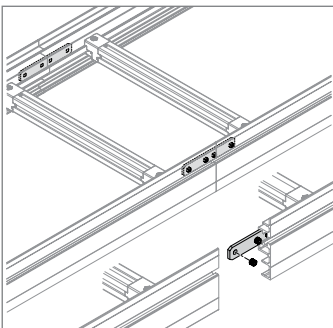

Profile connector AL		No.
	10	3842530277

Material: Steel, galvanized

Scope of delivery: Complete

Condition on delivery: Screws pre-assembled and secured

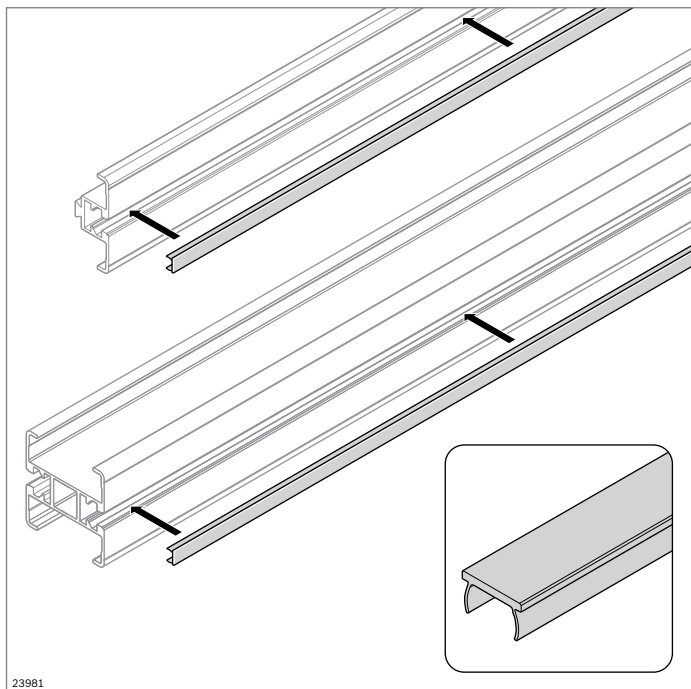

Cover profile

Cover profile to improve system design, to fix cables routed in the profile slot, and to protect the profile slot against contamination.



00109368

Cover profile AL	L (mm)	☒	No.
	2000	10	3842523258

Material: Aluminum; natural, anodized



19502

Cover profile PVC	L (mm)	☒	No.
Signal gray (RAL 7004)	2000	10	3842548876
Black (RAL 9005)	2000	10	3842548877
Light gray (RAL 7035)	2000	10	3842518367
Red (RAL 3020)	2000	10	3842518368
Yellow (RAL 1023)	2000	10	3842518369
Green (RAL 6032)	2000	10	3842549888
Blue (RAL 5010)	2000	10	3842538955
Orange (RAL 2004)	2000	10	3842538957
Colorless, transparent	2000	10	3842191182

Material: Hard PVC; colored

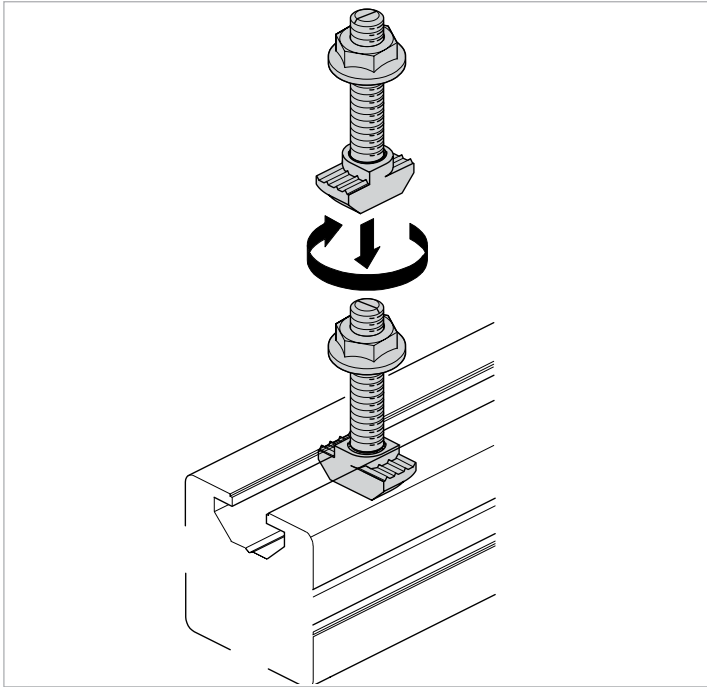

Flange nut

T-bolt

Fastening elements for mounting accessories on the profile slot

- ▶ Secure and conductive connection
- ▶ Notch at bolt end as marker for correct position recognition
- ▶ Profile finishing: Not required

There is a selection of different mounting options in the MGE catalog.

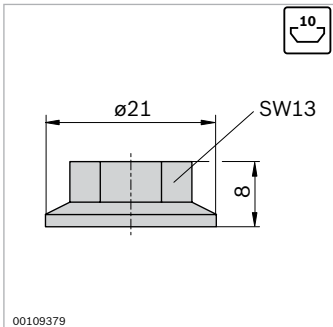

Flange nut	Slot	M		No.
	10	M8	100	3842345081

Material: Steel; galvanized

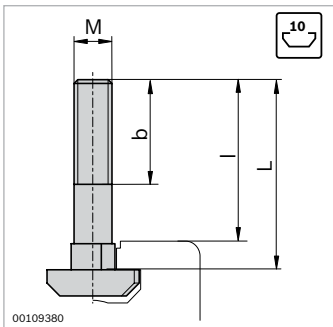

Slot	
10	6000 ... 18000 N ¹⁾

¹⁾ Dependent on the profile (see also "Technical data" in the MGE catalog)

T-bolt	Slot	MxL	b (mm)	L (mm)		No.
	10	M8x20	14	14	100	3842528715
		M8x25	19	19	100	3842528718
		M8x30	24	24	100	3842528721
		M8x40	22	34	100	3842528724
		M8x50	22	44	100	3842528727

Material: Steel; galvanized

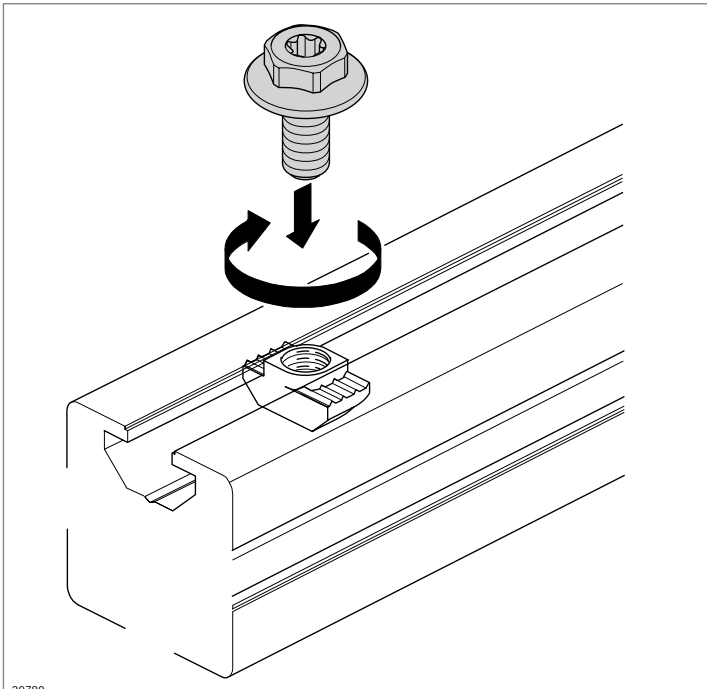

Collar screw

T-nut

- ▶ Collar screw with multi-function head for tightening with ring/open-end wrench (SW 13) or Torx screwdriver (T40)
- ▶ Machine tightening possible
- ▶ Preferably to be used for fastening brackets
- ▶ Quick and simple assembly
- ▶ Excellent force transmission via the wide flange
- ▶ With Polyfleck to secure the T-nut

Collar screw	M	L (mm)	☒	No.
	M8	20	100	3842541409

Material: Steel; galvanized

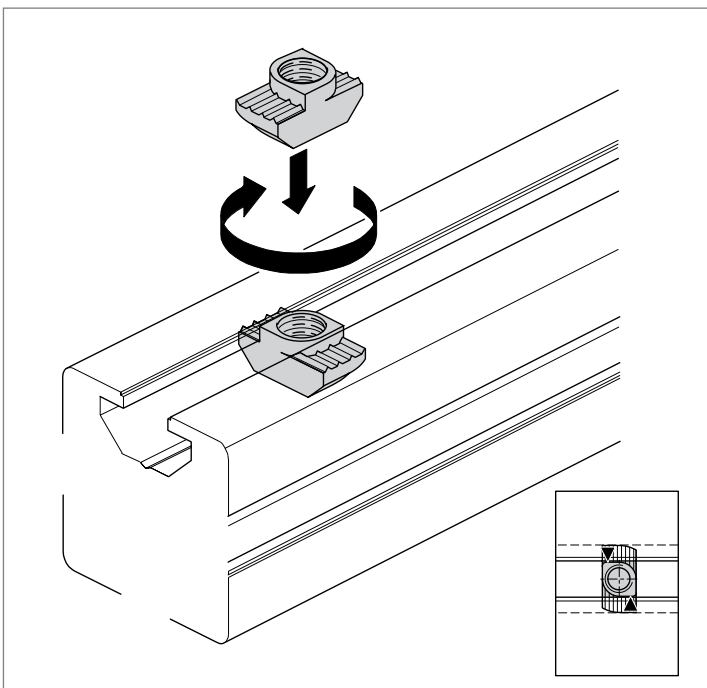

Fastening elements for mounting accessories on the profile slot

- ▶ Standard element for a secure and conductive connection
- ▶ End stop for correct positioning in the profile slot
- ▶ Profile finishing: Not required

T-nut	Slot	M	☒	No.
	10	M4	100	3842530281
		M5	100	3842530283
		M6	100	3842530285
		M8	100	3842530287

Material: Steel; galvanized



Horizontal curves

Horizontal curves are used to horizontally change the direction of the belts. The use of the complete modular belt surface is possible, since on the underside, the belt is equipped with integrated holding-down clamps. As a result, even overwide products can be transported on a horizontal section path. A straight section (L) must be installed in front of and/or behind a horizontal curve.

Modular belt width (mm)	Length L (mm)
406	256
608	458
x	x - 150

Between two horizontal curves in the opposite direction (S curve), a straight section (L) must be installed.

Modular belt width (mm)	Length L (mm)
406	512
608	916
x	2x - 300

► Use in abrasive environments is not permissible



Horizontal curve VFBelt 420 AL



Horizontal curve VFBelt 622 AL

30°

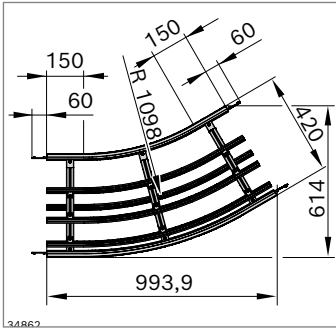

45°

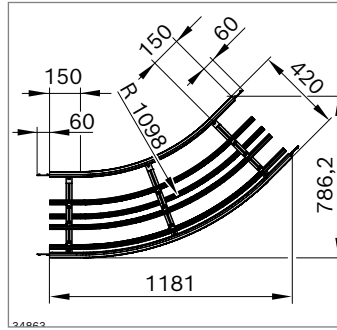

90°

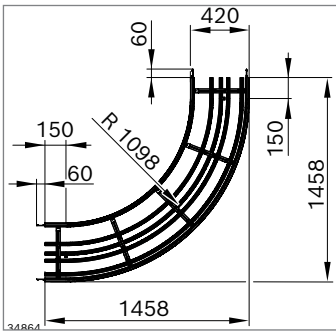

30°

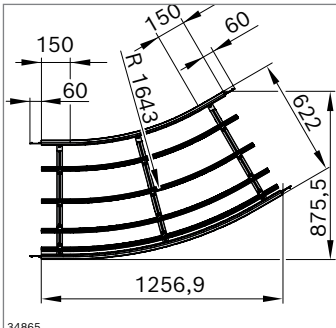

45°

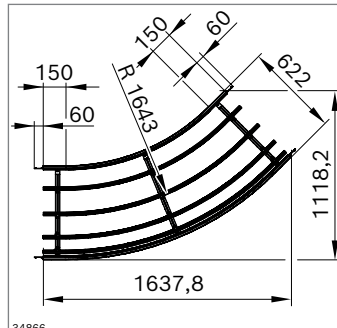

90°

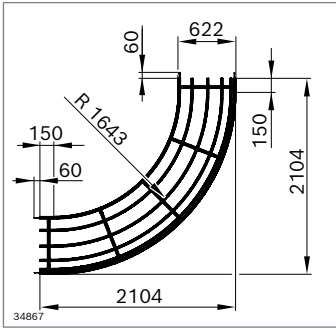

Horizontal curve	b	Bracket	No.
VFbelt 420 AL			
	420	30°	3842572114¹⁾
	420	45°	3842572115¹⁾
	420	90°	3842572116²⁾

1) Accessories, required:

▶ Clamping piece VFbelt (2x) (page 17)

2) Required accessories:

▶ Clamping piece VFbelt (3x) (page 17)

Material: Profile: Aluminum; anodized; profile connector: Steel; galvanized

Condition on delivery: Partly assembled

Additional track widths and deflection angles are available on request from our modification department (COS@boschrexroth.de).

Horizontal curve	b	Bracket	No.
VFbelt 622 AL			
	622	30°	3842572117¹⁾
	622	45°	3842572118¹⁾
	622	90°	3842572119²⁾

1) Accessories, required:

▶ Clamping piece VFbelt (2x) (page 17)

2) Required accessories:

▶ Clamping piece VFbelt (3x) (page 17)

Material: Profile: Aluminum; anodized; profile connector: Steel; galvanized

Condition on delivery: Partly assembled

Additional track widths and deflection angles are available on request from our modification department (COS@boschrexroth.de).

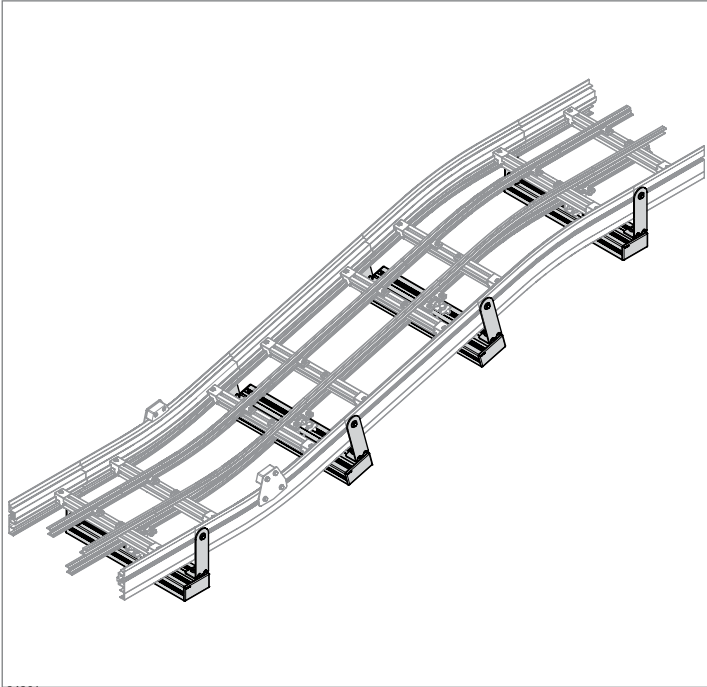

Vertical curves

Vertical curves are used for the transition from a horizontal conveyor section to an ascending section and vice versa. The construction is realized with two different curve segments (one upper and one lower). A straight section (L) must be installed in front of and behind vertical curves. Two additional support struts are required for the assembly of the attached support profile.

Modular belt width (mm)	Length L (mm)
406	256
608	458
x	x - 150

- ▶ Use in abrasive environments is not permissible
- ▶ Maximum belt tensile force: 450 N

Notice: A start ramp is recommended to limit the excessive spring deflection of the modular belt during start-up.



Upper vertical curve



Lower vertical curve

For guiding the modular belt close to the profile in the vertical curve, the usable track width is reduced by the use of lateral holding-down clamps. Despite the use of the holding-down clamps, the modular belt may bulge in the vertical curves. The maximum bulging can be up to 35 mm in the center of the belt, depending on curve angle, chain tensile force and speed.

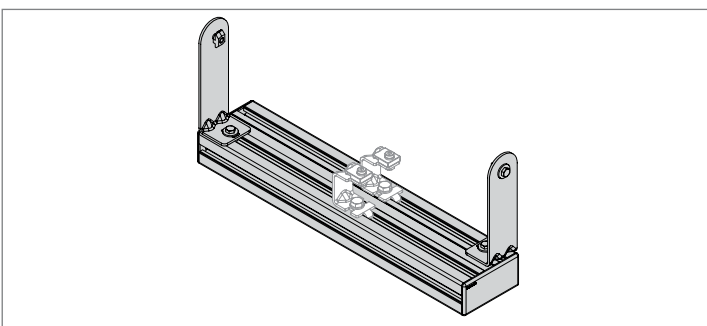

Support strut

The support strut serves to fasten the lower support profile in the vertical curve.

When using the static friction modular belt, the support strut should be constructed identically to the leg set of a static friction modular belt.

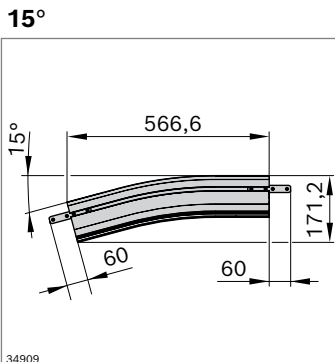
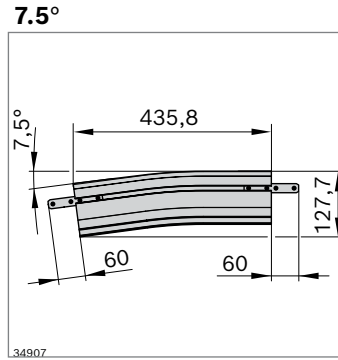
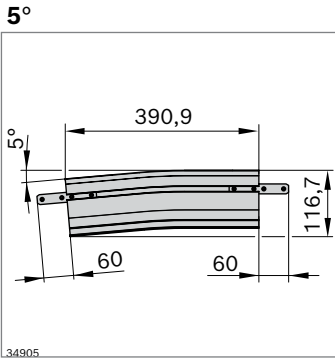

Upper vertical curve	b	Bracket	No.
VFbelt 420 AL			
	420	5°	3842572169
	420	7.5°	3842572170
	420	15°	3842572171

Material: Profile: Aluminum; anodized; profile connector: Steel; galvanized

Scope of delivery: Incl. fastening material

Accessories, required (per support strut):

- ▶ Strut profile 45x90L (1x) (3842992432) (L=b+6 mm)
- ▶ Cover cap 45x90 (2x) (3842548756)
- ▶ 10 mm supporting bracket STS (2x) (3842571257)
- ▶ Holder for modular belt support profile (2x) (3842572106)
- ▶ Clamping piece VFbelt (2x) (page 17)

Additional track widths are available on request from our modification department (COS@boschrexroth.de).

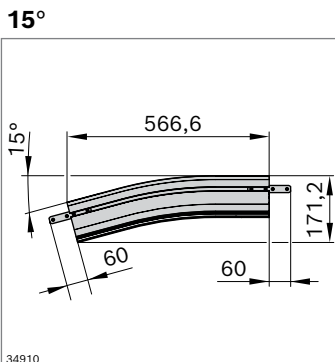
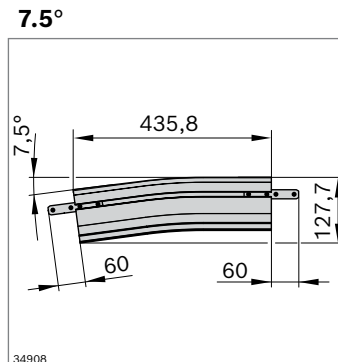
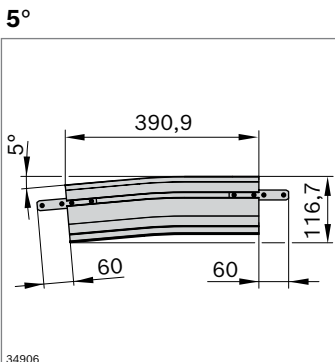

Upper vertical curve	b	Bracket	No.
VFbelt 622 AL			
	622	5°	3842572172
	622	7.5°	3842572173
	622	15°	3842572174

Material: Profile: Aluminum; anodized; profile connector: Steel; galvanized

Scope of delivery: Incl. fastening material

Accessories, required (per support strut):

- ▶ Strut profile 45x90L (1x) (3842992432) (L=b+6 mm)
- ▶ Cover cap 45x90 (2x) (3842548756)
- ▶ 10 mm supporting bracket STS (2x) (3842571257)
- ▶ Holder for modular belt support profile (2x) (3842572106)
- ▶ Clamping piece VFbelt (2x) (page 17)

Additional track widths are available on request from our modification department (COS@boschrexroth.de).

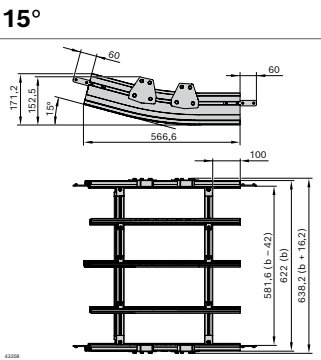
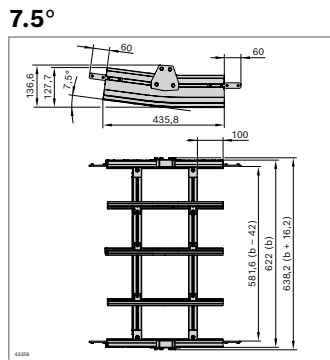
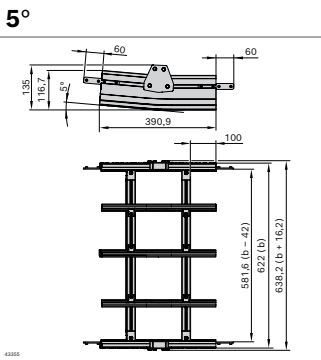
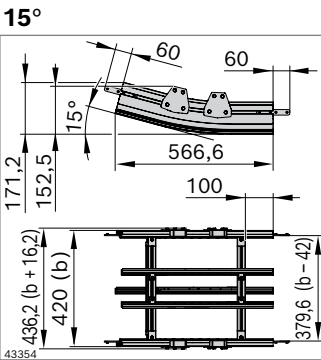
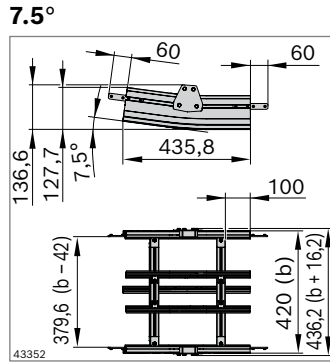
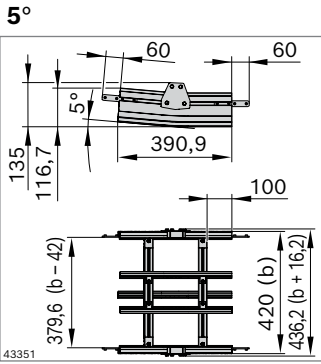

Lower vertical curve VFbelt 420 AL	b	Bracket	No.
	420	5°	3842572120
	420	7.5°	3842572121
	420	15°	3842572122

Material: Profile: Aluminum; anodized; profile connector: Steel; galvanized

Scope of delivery: Incl. fastening material

Accessories, required (per support strut):

- ▶ Strut profile 45x90L (1x) (3842992432) (L=b+6 mm)
- ▶ Cover cap 45x90 (2x) (3842548756)
- ▶ 10 mm supporting bracket STS (2x) (3842571257)
- ▶ Holder for modular belt support profile (2x) (3842572106)
- ▶ Clamping piece VFbelt (2x) (page 17)

Notice: Transport of oversized products is not possible when using the static friction modular belt in vertical curves!

Additional track widths are available on request from our modification department (COS@boschrexroth.de).

Lower vertical curve VFbelt 622 AL	b	Bracket	No.
	622	5°	3842572123
	622	7.5°	3842572124
	622	15°	3842572125

Material: Profile: Aluminum; anodized; profile connector: Steel; galvanized

Scope of delivery: Incl. fastening material

Accessories, required (per support strut):

- ▶ Strut profile 45x90L (1x) (3842992432) (L=b+6 mm)
- ▶ Cover cap 45x90 (2x) (3842548756)
- ▶ 10 mm supporting bracket STS (2x) (3842571257)
- ▶ Holder for modular belt support profile (2x) (3842572106)
- ▶ Clamping piece VFbelt (2x) (page 17)

Notice: Transport of oversized products is not possible when using the static friction modular belt in vertical curves!

Additional track widths are available on request from our modification department (COS@boschrexroth.de).

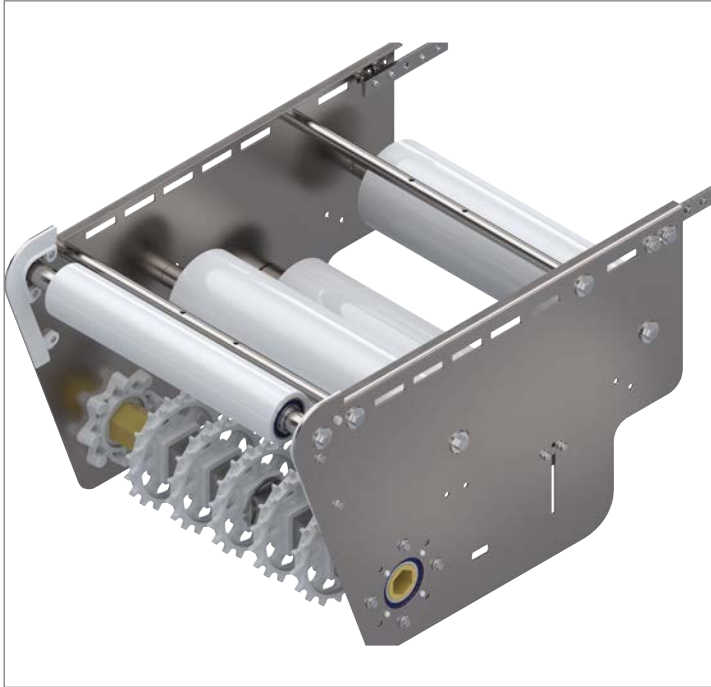

Drive and return unit

The basic unit is quickly turned into a head drive with variable mounting position by adding a drive kit. The two-side interface in the basic unit enables free selection of the motor mounting position on-site. The small diameter of the return rollers at the front also enables linear transfer of shorter products without the need for additional components to bridge the conveyor trench. After the drive and return unit, a straight section must be installed in the belt width (406/608 mm length).



Basic unit VFbelt direct 420/622

- ▶ Free choice of the motor mounting position on site
- ▶ Configurable drive kit (standard gear motor or round shaft)
- ▶ Maximum permissible belt tensile force: 1250 N
- ▶ Section length: $L \leq 30$ m
- ▶ Conveyor speed: v_N up to 40 m/min
- ▶ Not suitable for reversible operation
- ▶ Ball bearing made of non-rusting steel, with seal on both sides and FDA-compliant grease filling
- ▶ Side elements with mounting option to attach holders for lateral guides, or similar
- ▶ Linear transfer possible for conveyed materials from approx. 130 mm in length (depending on the speed, position of the center of gravity, friction)

Notice: If used in an accessible area, the drive must be secured by the customer. A trap guard for the flat modular belt is available on request from our modification department (COS@boschrexroth.de).

420

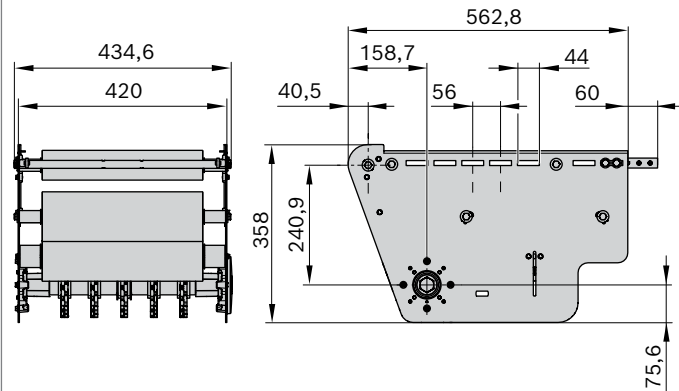

34225

622

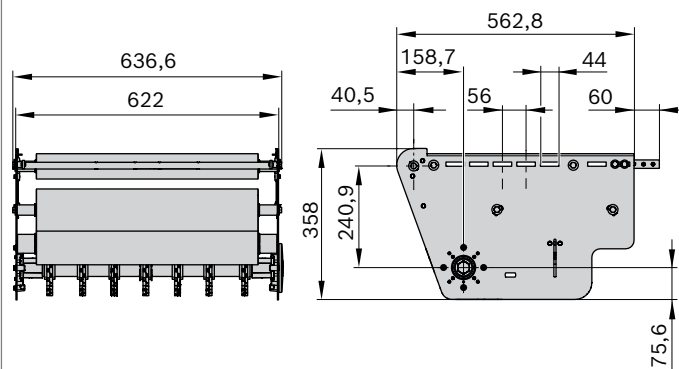

34226

Basic unit	b	No.
VFBelt direct	420	3842572108
	622	3842572109

Material: Side panel, shaft: Non-rusting steel/PA;
rollers: PE; toothed gears: POM

Scope of delivery: Incl. fastening material

Condition on delivery: Fully assembled

Accessories, required:

► VarioFlow belt drive kit (page 33)

Additional track widths are available on request from our modification department (COS@boschrexroth.de).



Return unit VFbelt 420/622

- ▶ Ball bearing made of non-rusting steel, with seal on both sides and FDA-compliant grease filling
- ▶ Side elements with mounting option to attach holders for lateral guides, or similar
- ▶ Linear transfer possible for conveyed materials from approx. 130 mm in length (depending on the speed, position of the center of gravity, friction)



Drive kit

The drive kit contains a flange for attaching the motor to the basic unit, a hexagonal shaft for transmission of force, as well as other optional equipment features.

- ▶ With Lenze gear motor (GM = 1, without surface and corrosion protection) or with an interface for attaching an SEW SA47 gear motor (GM = 2).
An adaptation by the customer is required for attaching other gear motors (GM = 0).
- ▶ Fixed or adjustable speed (v_N). For an adjustable speed, gear motors must be retrofitted with a frequency converter (see p. 34).
- ▶ Connections are made using terminal boxes (AT = K) or plugs (AT = S)

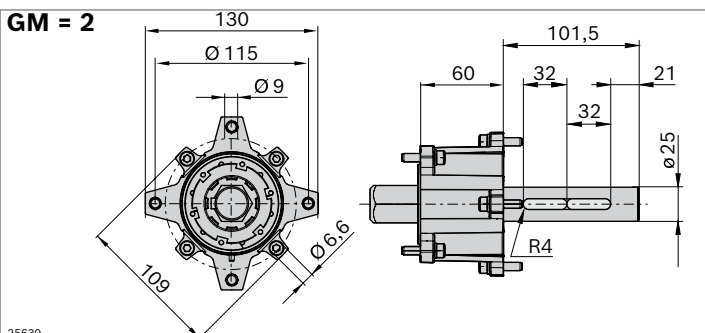
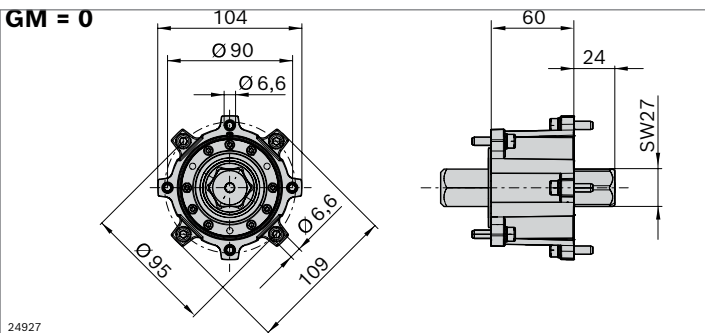
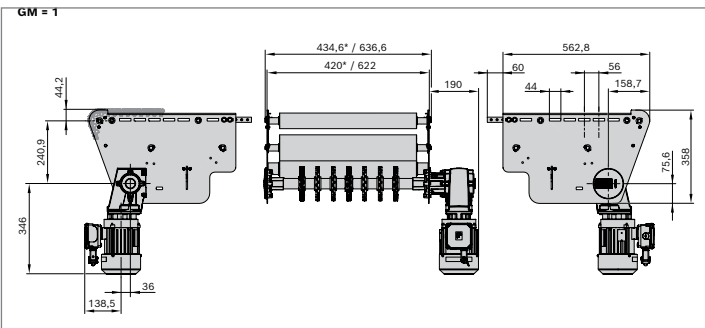
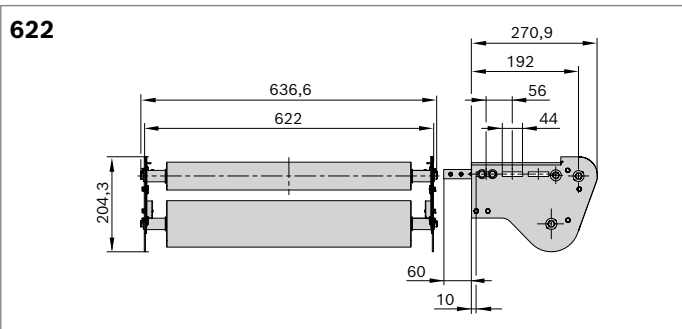
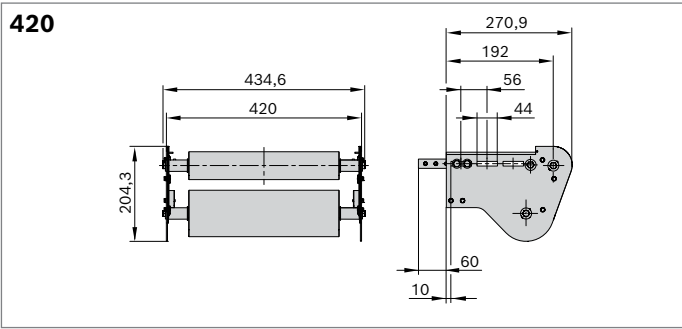

Return unit	b (size)	No.
VFbelt	420	3842572112
	622	3842572113

Material: Side panel, shaft: Non-rusting steel; rollers: PE

Scope of delivery: Incl. fastening material

Condition on delivery: Fully assembled

Additional track widths are available on request from our modification department (COS@boschrexroth.de).

VarioFlow belt drive kit	Nominal speed (m/min)	No.
	5, 10, 12, 15, 20, 25, 30, 38	3842994262

Material: Flange, motor: Die-cast aluminum; shaft: Non-rusting steel/PA

Scope of delivery: Incl. fastening material, flange, shaft and gear motor (GM = 1)

Accessories, recommended:

► Frequency converter (page 34)

Additional versions are available on request from our modification department (COS@boschrexroth.de).

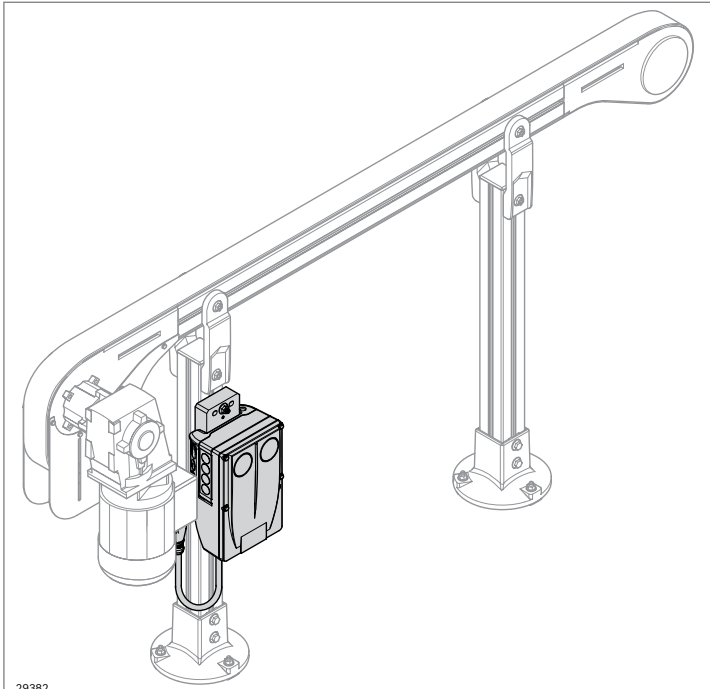

Frequency converter motec 8400

In order to operate a gear motor with adjustable speed, the motor needs to be retrofitted with a frequency converter (FU). The frequency converter has a modular design so that it can be easily mounted on a leg set and connected to the motor by cable.

- ▶ Connection power: 0.55 kW
- ▶ Speed (v_N) depending on the speed range of the gear motor used

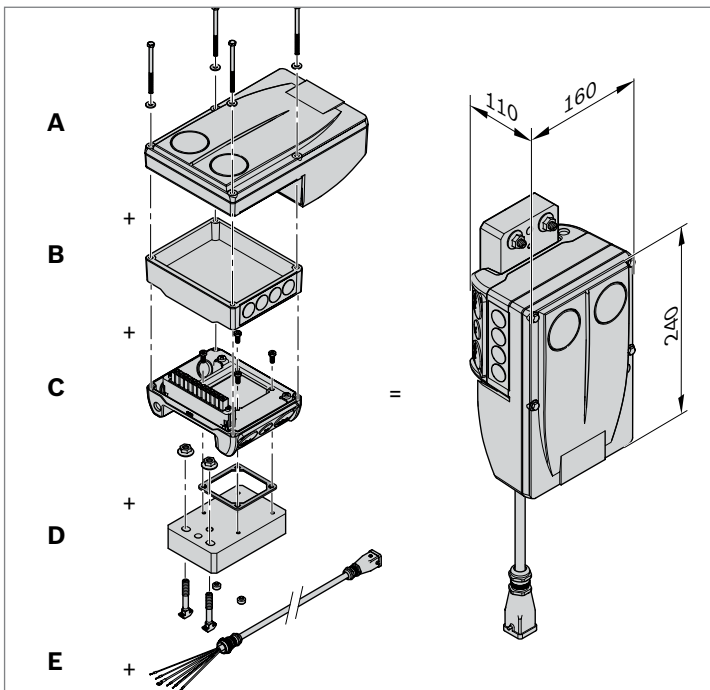

A complete frequency converter must be composed of the following modules

- ▶ Frequency converter power unit (A)
- ▶ Communication module (B)
- ▶ Connection unit (C)
- ▶ Attachment kit (D)
- ▶ Optional: Connection cable (E) for the plug-in connection to the gear motor (AT = S)

A

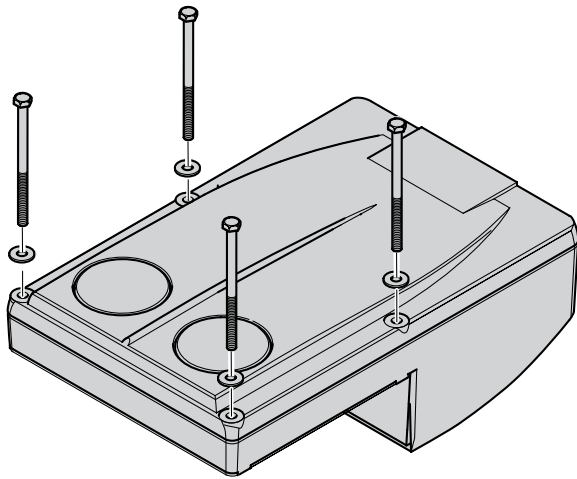

Frequency converter power unit (A)

Power unit: 0.55 kW

3/PE AC 320 V -0 % ... 528 V +0 %, 45 Hz -0 % ... 65 Hz +0 %

- ▶ Easy commissioning via manual control unit
- ▶ Easy-to-replace memory module
- ▶ Large LED status indicator

Frequency converter	No.
0.55 kW power unit	3842553447

The speed range of the frequency converter is based on the base speed of the motor:

Speed range (m/min) 50 Hz	Min ¹⁾ (m/min)	Max ²⁾ (m/min)
5	2	5
10	1	11
12	4	14
15	5	18
20	6	23
25	8	29
30	10	36
38	12	44

¹⁾ Min corresponds to approx. 16 Hz supply frequency

²⁾ Max corresponds to approx. 60 Hz supply frequency
At 460 V/60 Hz max (m/min), approx. 20% higher

B

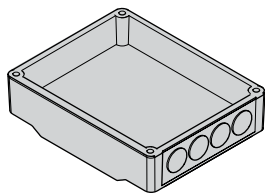

29385

Communication module (B)

- ▶ Used to control the frequency converter
- ▶ Cable connection options
- ▶ Standard version without "integrated safety system STO (safety torque off)" (available on request)

Depending on their function, the individual communication modules are provided with the corresponding connections.

Communication module	No.
Standard I/O	3842553449
AS-i	3842553453
CANopen	3842553454
EtherNet/IP	3842553451
EtherCAT	3842553459
PROFIBUS	3842553452
PROFINET	3842553450

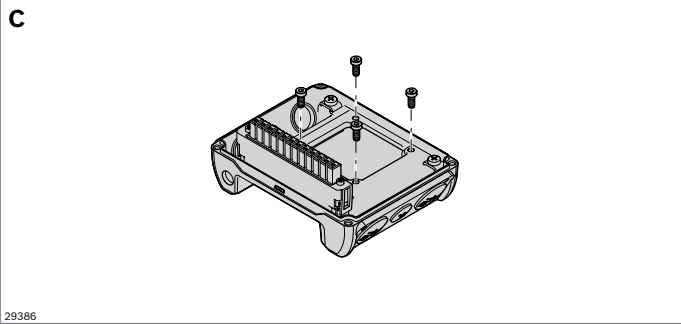

Connection unit (C)

- ▶ Power grid connection options

Connection unit	No.
	3842553445

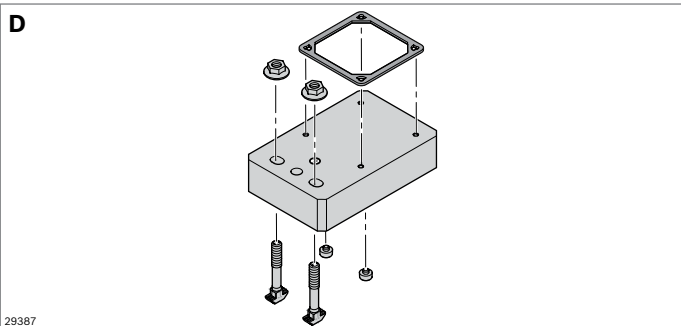

Attachment kit (D)

- ▶ For the simple attachment of the frequency converter (FUs) to the AL leg set (slot/s with a 60 or 80 strut profile)

Attachment kit	No.
	3842553457

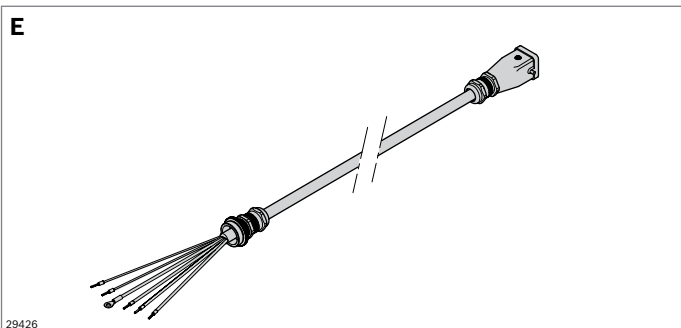

Connection cable (E)

- ▶ For connecting the gear motor to the frequency converter (length: 1 m)
- ▶ For the drive kit AT = S (direct wiring with AT = K)

Connection cable	No.
	3842553512

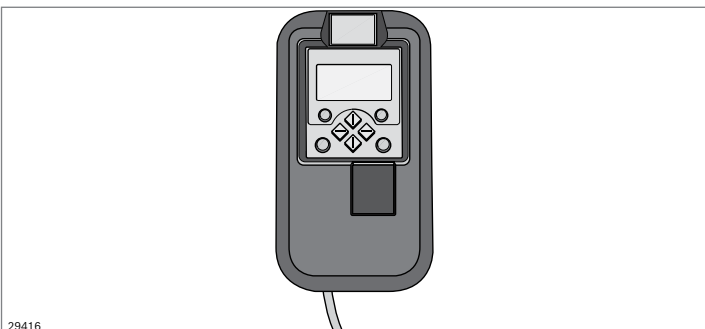

Manual control unit

The manual control unit is required for the parameterization of drives with frequency converters.

In addition, you can:

- ▶ Control (e.g. block and release)
- ▶ Display operating data
- ▶ Infinitely regulate the transport speed
- ▶ Transfer parameter sets to other basic devices

Manual control unit	No.
	3842552821



Leg sets

The modular belt conveyor is set up on the floor and secured by means of leg sets. Leg sets must be mounted on the drive and in close proximity to the return unit, under section joints and in curves. Depending on speed, accumulation behavior and weight, leg sets must be installed at a distance of approx. 2 m.

Notices:

- ▶ When using the static friction modular belt in an accessible area, the standard leg set cannot be used and the distance between the cross profile and the returning modular belt must be increased. The drive must be secured against access by the customer.
- ▶ 90° curves always require 3 leg sets.

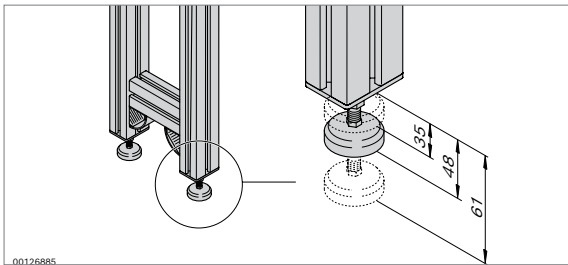

Fastening material

Leg sets must be anchored to the floor with foundation brackets (3842146848, including flange nut M8 (3842345081) and T-bolt M8x20 (3842528715)) and floor dowels (3842526560).

Leveling feet

The specified system height H refers to the mean leveling foot height. The adjustment range of +/- 13 mm enables compensation of unevenness in the floor.

Standard leg set

Accessories		No.
Foot (A)	20	3842352061
Strut profile 60x60 (W) (profile length L = H-277)	1	3842990351
Strut profile 60x60 (C1) (profile length b+40)	1	3842990350
Strut profile 60x60 (C2) (profile length b-80)	1	
Cover cap (D)	100	3842548808
Cover cap (E)	20	3842548852
Bracket (F)	1	3842523553
Support profile holder (G)	1	3842572106
Supporting bracket (H)	Set	3842546632
Cover cap 60x60, with hole	20	3842548810

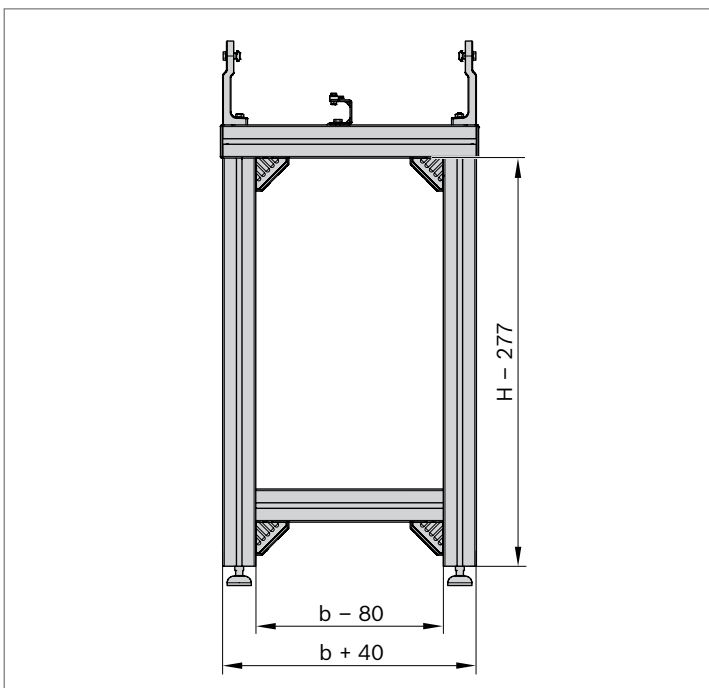

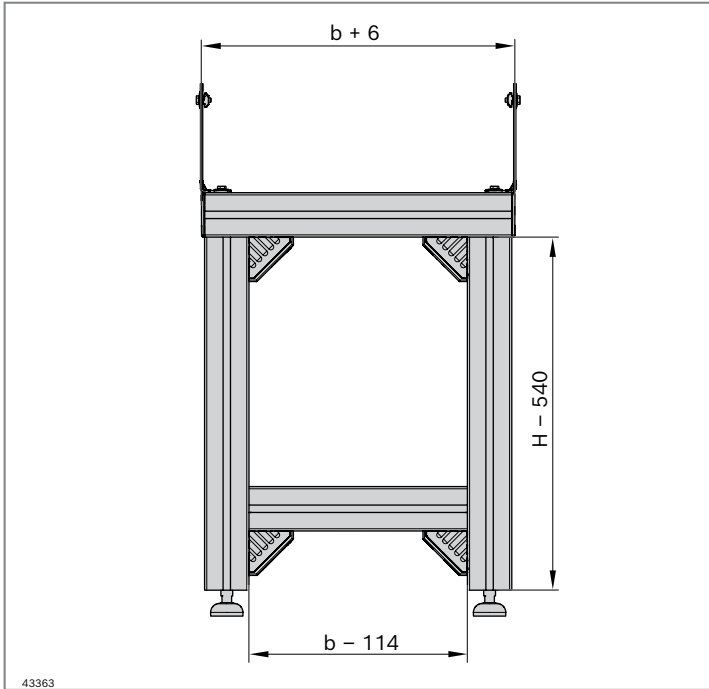

Basic unit leg set

Accessories	No.	
Foot (A)	20	3842352061
Strut profile 60x60 (W) (profile length L = H-540)	1	3842990351
Strut profile 60x60 (C1) (profile length b+6)	1	3842990350
Strut profile 60x60 (C2) (profile length b-114)	1	
Cover cap (D)	100	3842548808
Cover cap (E)	20	3842548852
Bracket (F)	1	3842523553
Supporting bracket (I)	1	3842571257
Cover cap 60x60, with hole	20	3842548810
T-nut 10 M6 STS	20	3842546706

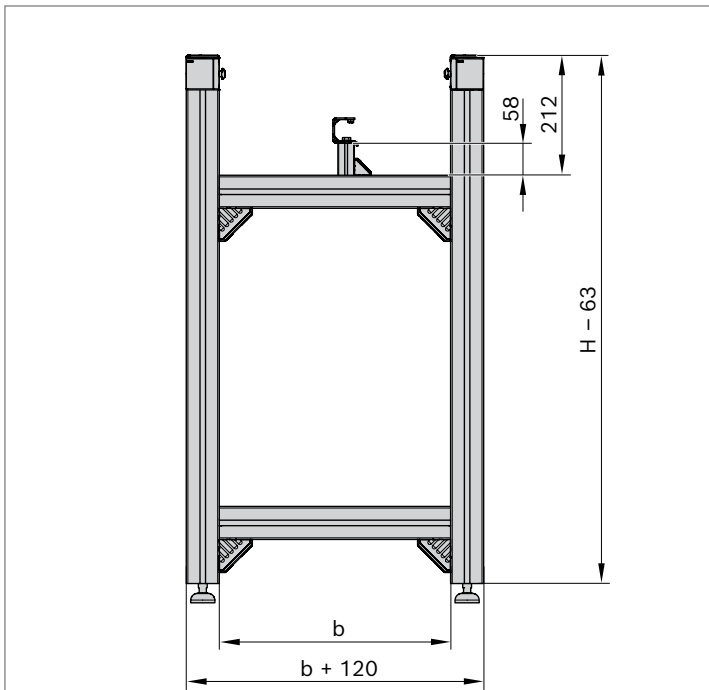

Leg sets static friction modular belt

When using the static friction modular belt in an accessible area, the leg set for the static friction modular belt is to be used due to the increased distance between the cross profile and the returning modular belt and the respectively reduced risk of drawing-in.

Component	No.	
Foot (A)	20	3842352061
Strut profile 60x60 (W) (profile length L = H-63)	1	3842990351
Strut profile 60x60 (C) (profile length b)	1	3842990350
Cover cap (D)	100	3842548808
Cover cap (E)	20	3842548852
Bracket (F)	1	3842523553
Support profile holder (G)	1	3842572106
Strut profile 30x30 M8/- (J)	1	3842990721/58
Bracket 30x30 (K)	1	3842523530
Cover cap (L)	100	3842548846
Cover cap 60x60, with hole	20	3842548810



Supporting bracket Vfbelt AL		No.
	Set	3842546632

- ▶ Supporting bracket is easily centered in the slot thanks to centering lugs
- ▶ Easy-to-clean design with draining surfaces

Material: Diecast aluminum; silver

Scope of delivery: Set (2 pcs) incl. fastening material



Supporting bracket Vfbelt STS 10 mm		No.
	1	3842571257

- ▶ Space-saving supporting bracket for realizing parallel sections with narrow track distances

Material: Non-rusting steel 1.4301

Scope of delivery: (1 pc) incl. fastening material (except for T-nuts)

Accessories, required:

- ▶ T-nut 10 M6 AL (galvanized: 3842530285; STS: 3842536604)
- ▶ T-nut 10 M6 STS (3842546706)



Holder for modular belt support profile

The holder is the connection element between support profile and leg set.

Holder for modular belt support profile	QTY	No.
	1	3842572106

Material: Non-rusting steel

Accessories, required:

- T-nut slot 10 mm, M8 steel, galvanized (page 23) or stainless steel (3842536603)

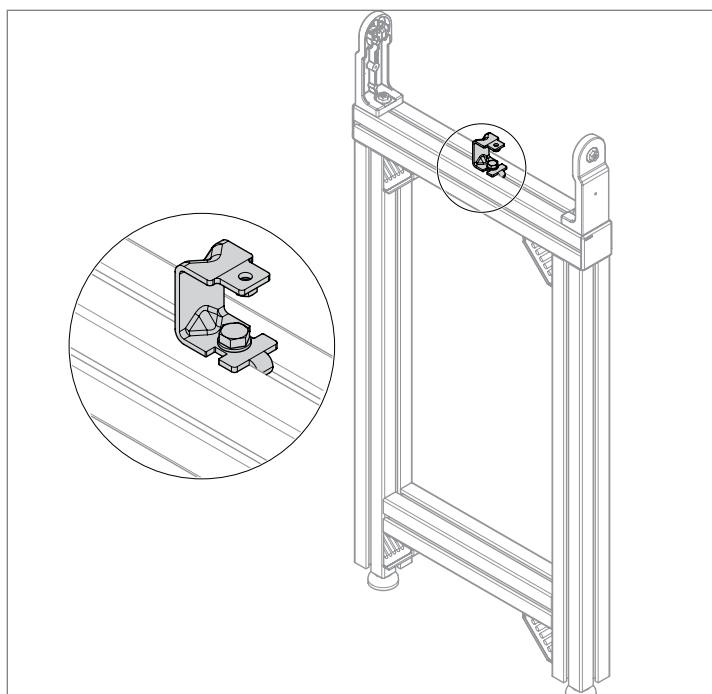
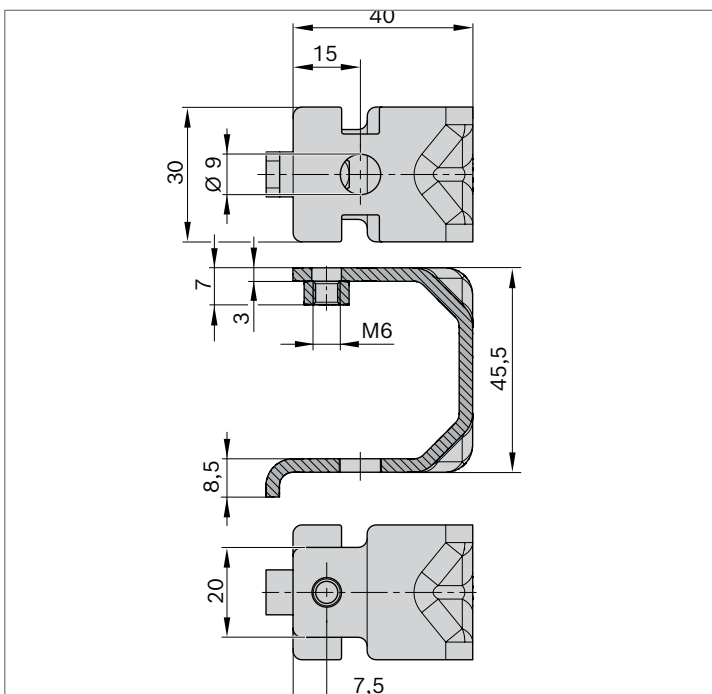



Product guide

- ▶ Wide variety of profile rail and holder combinations for individual solutions
- ▶ Easy to clean thanks to ample draining surfaces
- ▶ Robust
- ▶ Only one tool required for adjustment
- ▶ Interface slot 10 mm
- ▶ Holder and clamping holder allow for the variable adjustment of the guide height and width

Notice: For lateral guide stability, at least two holders must be connected with a continuous profile rail.

System dimensions

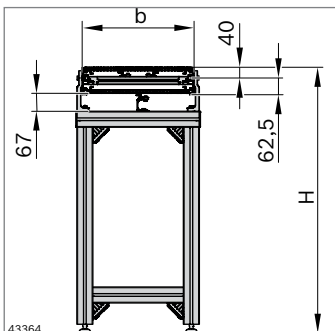

System dimensions: flat modular belt

Notice: Static friction coating 5 mm higher

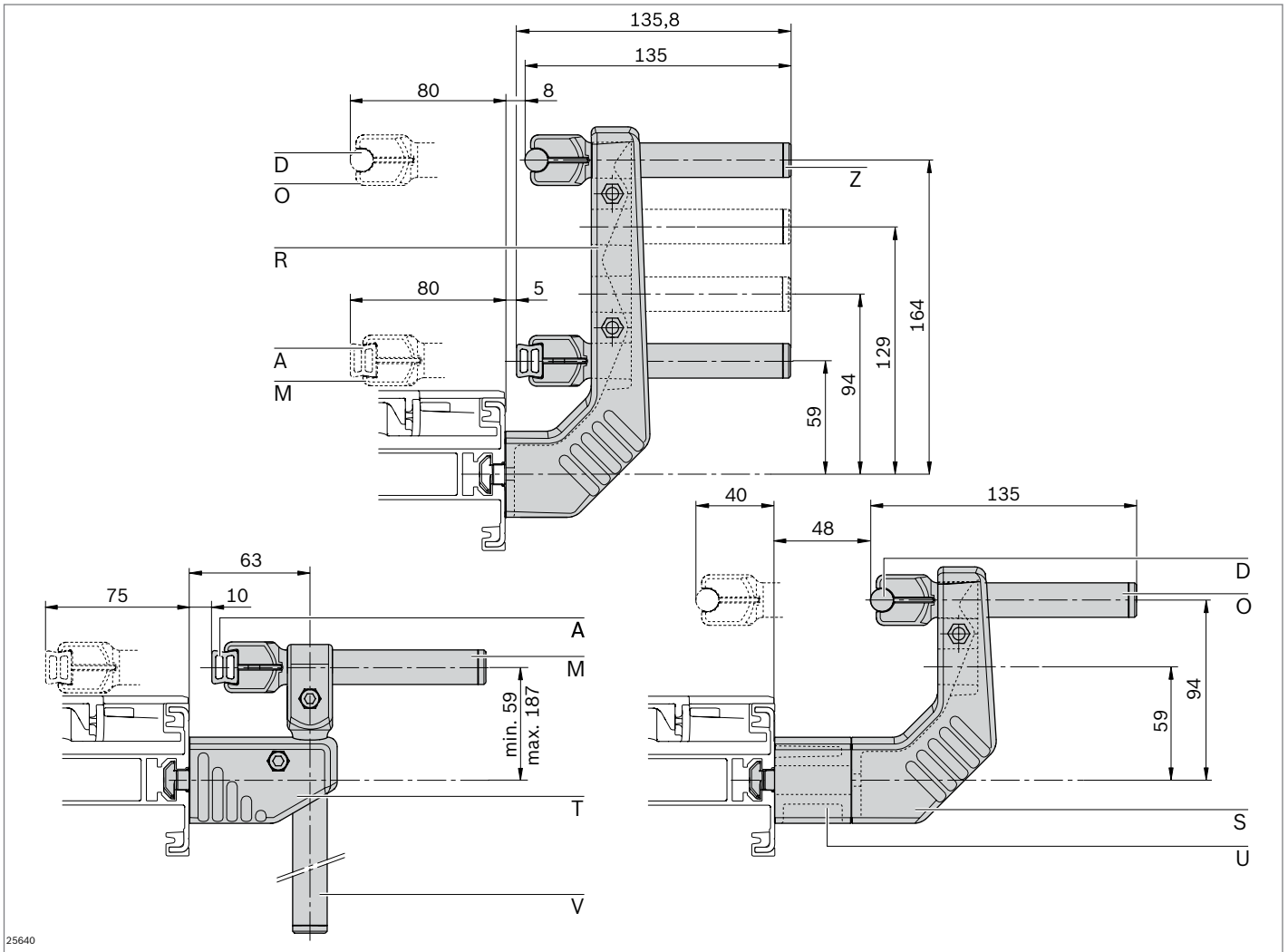

- A:** Aluminum profile rail (page 52)
- D:** Profile rail D12 (page 44)
- M:** Clamping holder C L100 (page 46)
- O:** Clamping holder D12 L100 (page 46)
- R:** Holder L204 (page 47)
- S:** Holder L134 (page 47)
- T:** Holder L45 (page 48)
- U:** Spacer (page 48)
- V:** Vertical clamping holder D18 L160 (page 48)
- Z:** Plug (page 49)

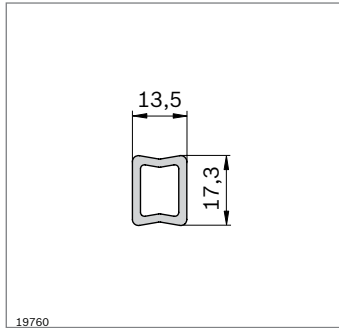
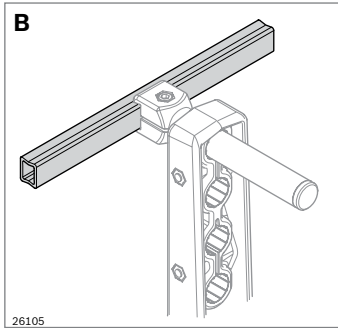

- ▶ HDPE profile rail for light applications
- ▶ Bendable
- ▶ Holder distance: Approx. 300 mm
- ▶ Accessories: Sliding rail narrow (E); sliding rail high (F); outer profile connector (G); inner profile connector (H); cover cap (I); clamping holder C L100 (M); clamping holder C (N); holder (J); clamping head (L); clamping head (Q)

HDPE profile rail		L (mm)	No.
B	1 pc	3000	3842538388

Material: HDPE; gray

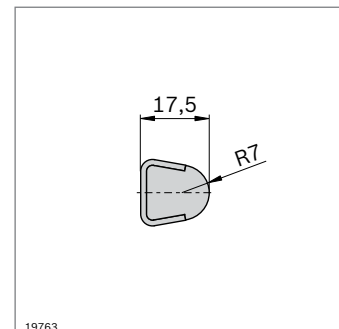
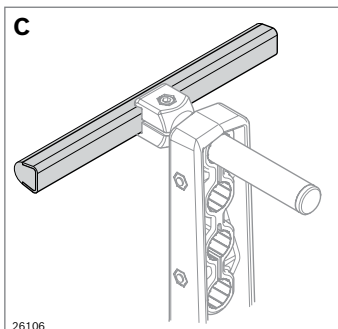

- ▶ Profile rail 17x17.5 in robust design made of non-rusting steel 1.4301 with PE guide protecting the product
- ▶ Holder distance: Max. 750 mm, less with accumulation pressure
- ▶ Accessories: Outer profile connector (G); clamping holder C L100 (M); clamping holder C (N); holder (J); clamping head (L); clamping head (Q)

Profile rail 17x17.5		L (mm)	No.
C	1 pc	200 ... 3000	3842994863
C	20 pcs	3000	3842529850

Material: Steel; non-rusting/PE; natural

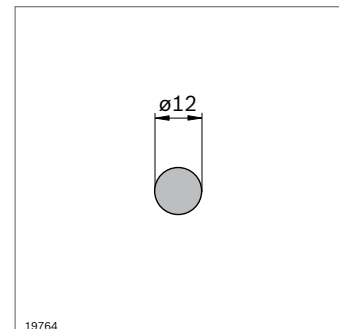
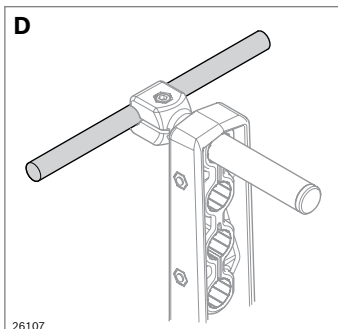

- ▶ Profile rail D12 in robust design made of non-rusting steel 1.4301
- ▶ Holder distance: Max. 750 mm, less with accumulation pressure
- ▶ Accessories: Clamping holder D12 L100 (O); clamping holder D12 (P)

Profile rail D12		L (mm)	No.
D	1 pc	200 ... 3000	3842993306/L
D	6 pcs	3000	3842533841

Material: Steel; non-rusting

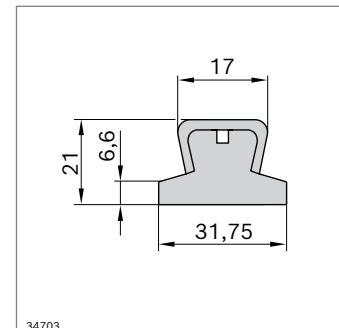
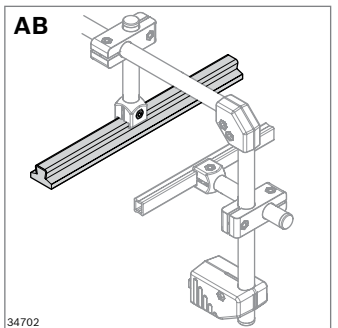

- ▶ T-profile rail for simple section separation or lateral guiding of transported material
- ▶ In robust version made of non-rusting steel with PE guide for gentle product handling
- ▶ Holder distance: Approx. 750 mm, less with accumulation pressure

Profile rail T21x32		L (mm)	No.
AB		3000	3842571233

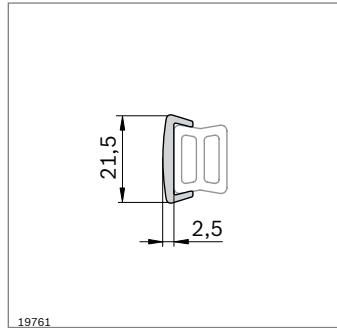
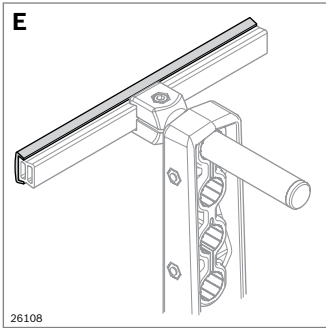

- ▶ Clip-on sliding rail for aluminum or HDPE profile rail
- ▶ For gentle product transport and minimum wear to profile rail HDPE

Sliding rail, narrow	L (mm)	No.
E	3000	3842538209

Material: HPDE; gray

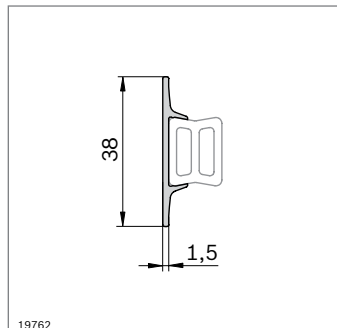
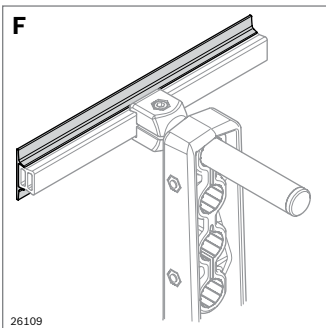

- ▶ Clip-on sliding rail for aluminum or HDPE profile rail
- ▶ Wide guiding surface
- ▶ For gentle product transport and minimum wear to profile rail HDPE

Sliding rail, high	L (mm)	No.
F	3000	3842538389

Material: HDPE; gray

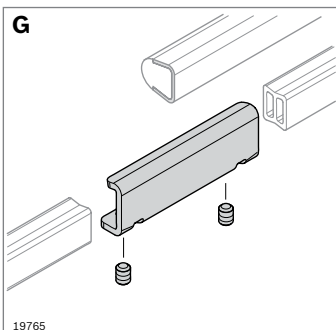

- ▶ Outer profile connector for aluminum profile rails (A), HDPE profile rail (B), 17x17.5 profile rail (C)

Outer profile connector	⊠	No.
G	10	3842539613

Material: Steel; non-rusting

Scope of delivery: Incl. 2x headless setscrews

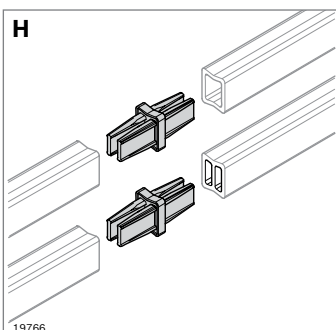

- ▶ Inner profile connector for profile rail in aluminum (A), profile rail HDPE (B)

Internal profile connector	⊠	No.
H	10	3842539345

Material: PA; black, conductive

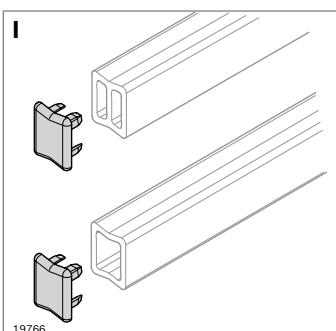

- ▶ Cover cap for aluminum (A) profile rail, HDPE (B) profile rail

Cover cap	⊠	No.
I	10	3842538208

Material: PA; black, conductive

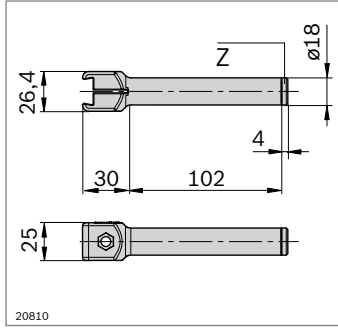
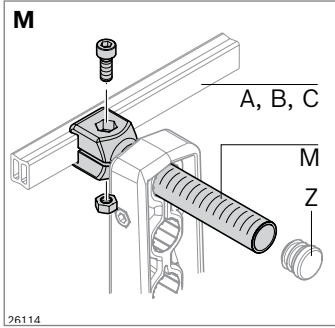

- ▶ Clamping holder C L100 for supporting aluminum (A), HDPE (B) or 17x17.5 (C) profile rail versions
- ▶ Scaling in mm and inch for simple alignment
- ▶ Accessories: Plug (Z)

Clamping holder C L100		No.
M	10	3842539499

Material: Clamping holder: PA; black; nut, screw: Steel; non-rusting

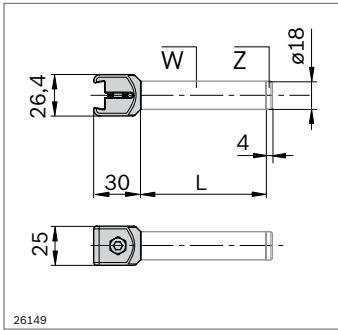
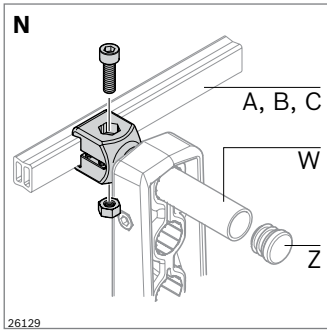

- ▶ Clamping holder C for mounting profile rails aluminum (A), HDPE (B) or 17x17.5 (C) profile rail versions
- ▶ In conjunction with tube 18 (W) for constructing longer clamping holders
- ▶ Accessories: Plug (Z), tube D18 (W)

Clamping holder C		No.
N	10	3842547228

Material: Clamping holder: PA; black; nut, screw: Steel; non-rusting

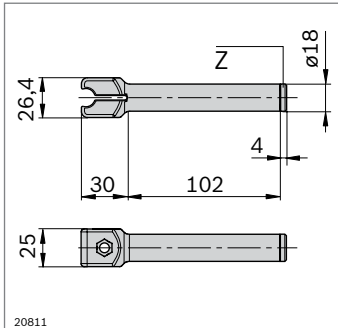
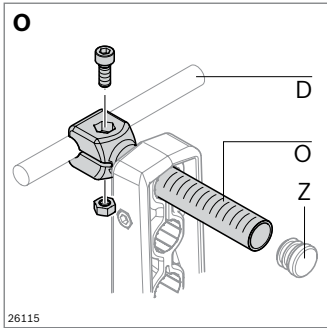

- ▶ Clamping holder D12 L100 for supporting profile rails D12 (D)
- ▶ Scaling in mm and inch for simple alignment
- ▶ Accessories: Plug (Z)

Clamping holder D12 L100		No.
O	10	3842539498

Material: Clamping holder: PA; black; nut, screw: Steel; non-rusting

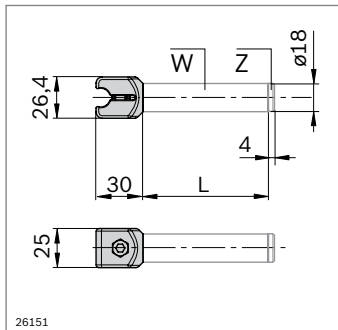
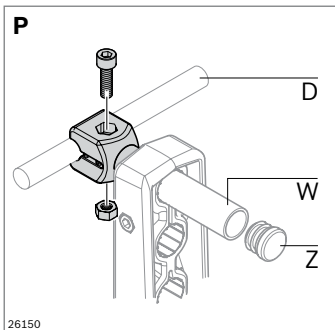

- ▶ Clamping holder D12 for supporting profile rails D12 (D)
- ▶ In conjunction with tube 18 (W) for constructing longer clamping holders
- ▶ Accessories: Plug (Z), tube D18 (W)

Clamping holder D12		No.
P	10	3842547227

Material: Clamping holder: PA; black; nut, screw: Steel; non-rusting

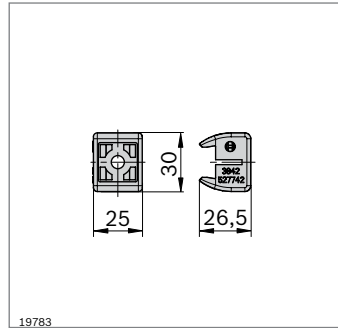
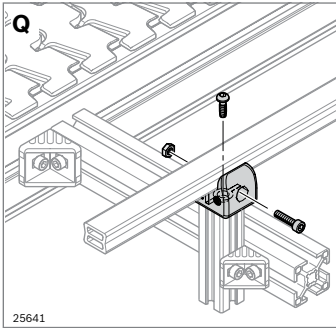

- ▶ Clamping head for supporting aluminum (A), HDPE (B) or non-rusting steel 1.4301 profile rail versions with PE guide (C)
- ▶ Direct mounting on profiles with 10 mm slot

Clamping head			No.
Q	Set	10	3842528009

Material: Clamping holder: PA, black; fastening material: Steel; galvanized

Scope of delivery: Incl. fastening material

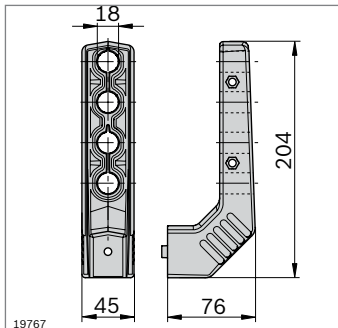
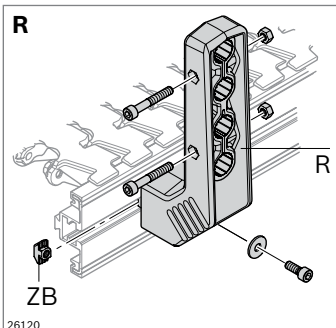

- ▶ Holder for fastening clamping holders C, C L100, D12, or D12 L100
- ▶ Various installation heights possible for clamping holders
- ▶ Variable guide widths possible
- ▶ Spacer (U) for added enlargement of guide width
- ▶ Accessories, required: T-nut for AL or STS
- ▶ Accessories, recommended: Spacer (U)

Holder L204			No.
R	Set		3842539494
ZB	T-nut for AL	100	3842530285
ZC	T-nut for STS	20	3842546706

Material: PA; black

Fastening material: Steel; non-rusting

Scope of delivery: Incl. fastening material (except for T-nuts)

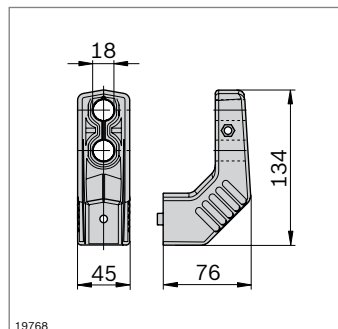
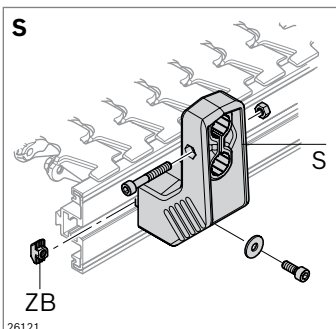
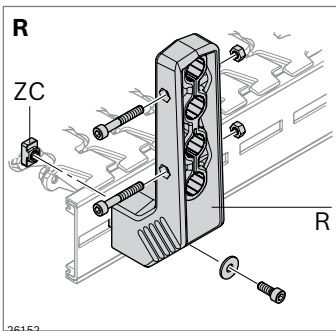

- ▶ Holder for fastening clamping holders C, C L100, D12, or D12 L100
- ▶ Various installation heights possible for clamping holders
- ▶ Variable guide widths possible
- ▶ Spacer (U) for added enlargement of guide width
- ▶ Accessories, required: T-nut for AL or STS
- ▶ Accessories, recommended: Spacer (U)

Holder L134			No.
S	Set		3842539495
ZB	T-nut for AL	100	3842530285
ZC	T-nut for STS	20	3842546706

Material: PA; black

Fastening material: Steel; non-rusting

Scope of delivery: Incl. fastening material (except for T-nuts)

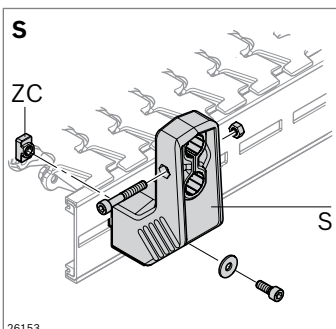

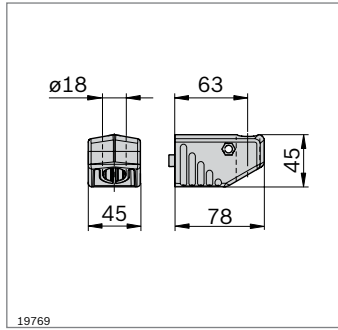
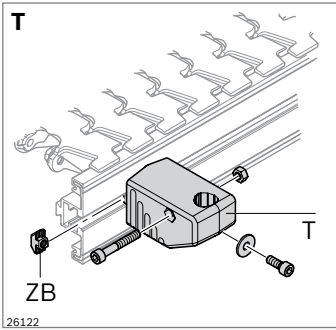

- ▶ Holder L45 for fastening vertical clamping holders or tube D18
- ▶ For infinitely height-adjustable lateral guides
- ▶ Spacer (U) for enlargement of guide width
- ▶ Accessories, required: T-nut for AL or STS
- ▶ Accessories, recommended: Spacer (U)

Holder L45		📦	No.
T	Set	10	3842539496
ZB	T-nut for AL	100	3842530285
ZC	T-nut for STS	20	3842546706

Material: PA; black;
Nut, screw: Steel; non-rusting

Scope of delivery: Incl. fastening material (except for T-nuts)

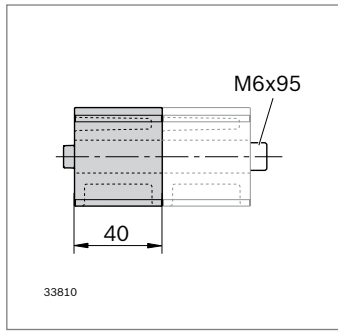
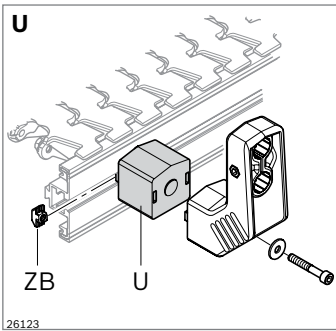
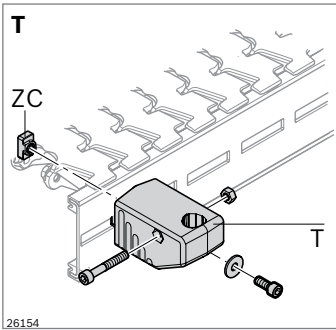

- ▶ Spacer for guide width enlargement
- ▶ 2 versions can be combined as desired, pluggable
- ▶ Centering lug for easy assembly
- ▶ Stable connection thanks to stainless steel core
- ▶ Accessories, required: T-nut for AL or STS

Spacer		📦	No.
U	Set 40 mm	10	3842539497
U	Set 10 mm	10	3842567773
ZB	T-nut for AL	100	3842530285
ZC	T-nut for STS	20	3842546706

Material: PA; black;
Fastening material: Steel; non-rusting

Scope of delivery: Incl. fastening material (except for T-nuts)

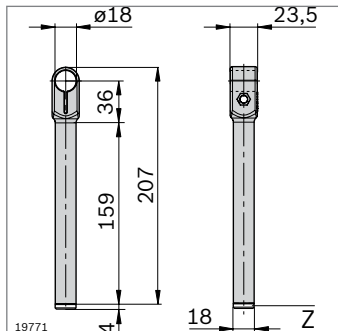
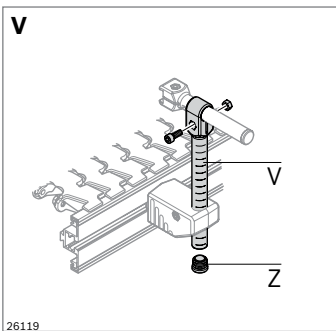
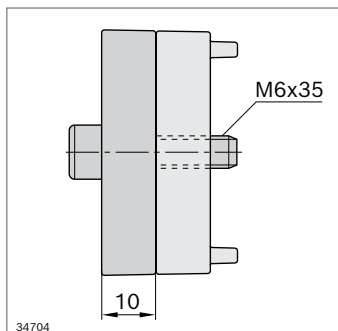
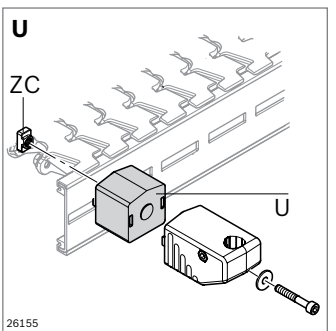

- ▶ Vertical clamping holder for constructing height-adjustable guides
- ▶ Accessories: Plug (Z)

Vertical clamping holder D18 L160		📦	No.
V		10	3842539500

Material: PA; black;
Nut, screw: Steel; non-rusting

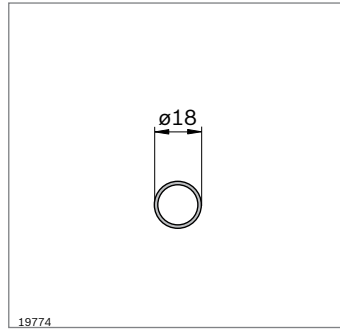
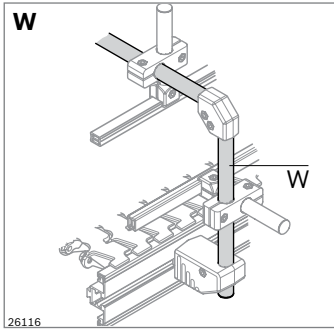

- ▶ Tube D18 for constructing height-adjustable vertical holders or cross members for upper guides
- ▶ Accessories: Plug (Z)

Tube D18	L (mm)	No.
W	3000	3842539339

Material: Non-rusting steel 1.4301

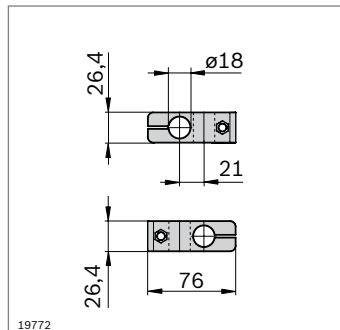
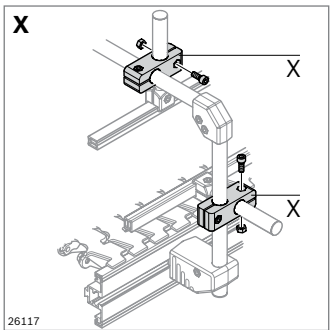

- ▶ Cross piece for the intersecting, right-angled connection of tubes D18 (W) and clamping holders C L100 (M) or D12 L100 (O)

Cross piece	No.
X	10 3842539501

Material: Cross piece: PA; black
Nut, screw: Steel; non-rusting

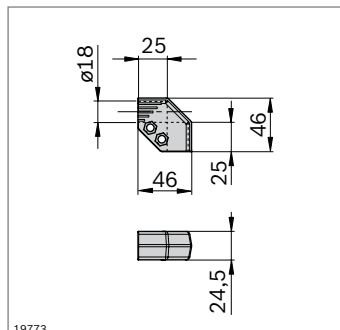
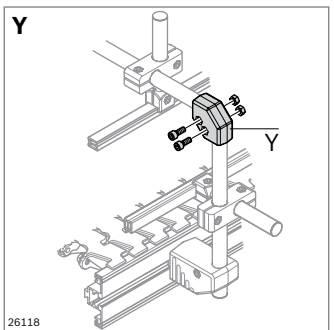

- ▶ Corner piece for end-to-end, perpendicular connections of tubes D18 (W) and clamping holders C L100 (M) or D12 L100 (O)

Corner piece	No.
Y	10 3842539505

Material: Corner piece: PA; black
Nut, screw: Steel; non-rusting

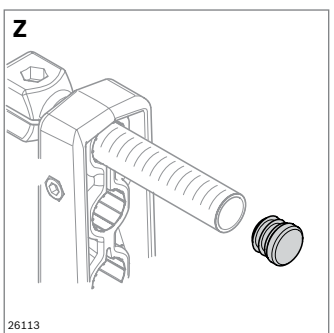

- ▶ Plug for clamping holder C L100 (M), clamping holder D12 L100 (O), vertical clamping holder D18 L160 (V) or tube D18 (W)

Plug	No.
Z	10 3842539826

Material: PA; black

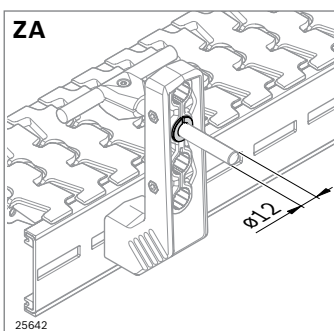

- ▶ Reducing adapter for mounting round profiles Ø12 in attachments D18, e.g. for customer-specific clamping holder

Reducing adapter	No.
ZA	20 3842539344

Material: PA; black

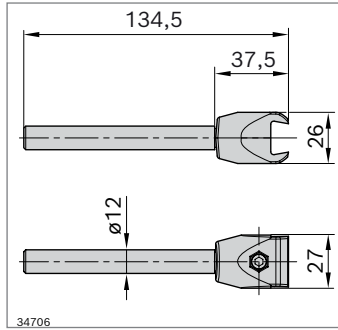
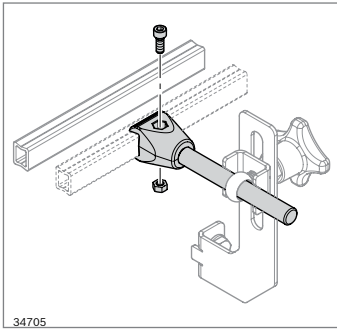

- ▶ Clamping holder C L80 for accommodating aluminum profile rails (A), HDPE (B), 17×17.5 (C) or T 21×32
- ▶ Accessories: Stainless steel holder, clamping bracket, star knob

Clamping holder C L80	No.
	10 3842571168

Material: Clamping head: PA;
Clamping rod, fastening material: Steel; non-rusting

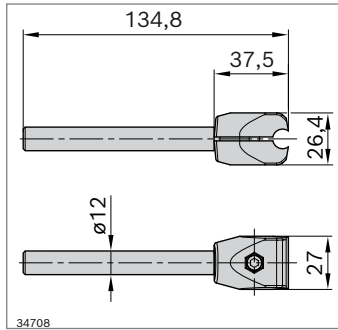
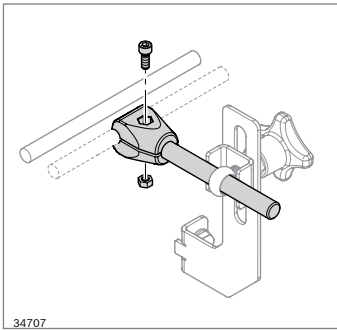

- ▶ Clamping holder C for accommodating profile rails D12
- ▶ Accessories: Stainless steel holder, clamping bracket, star knob

Clamping holder D12 L80	No.
	10 3842571169

Material: Clamping head: PA;
Clamping rod, fastening material: Steel; non-rusting

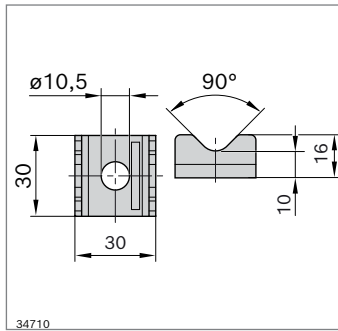
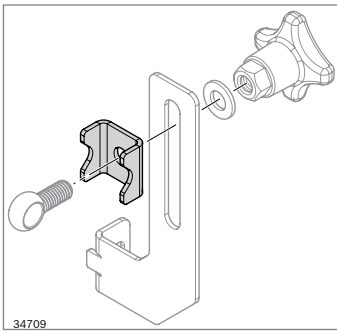

- ▶ Clamping bracket for secure fastening of the clamping holders at the stainless steel holder
- ▶ Accessories: Stainless steel holder, star knob

Clamping bracket	No.
	10 3842571173

Material: Clamping head: PA;
Clamping rod, fastening material: Steel; non-rusting

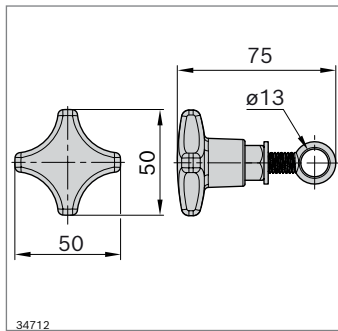
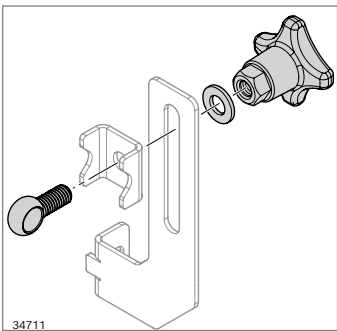

- ▶ Star knob with eye for quick, easy adjustment of the clamping holders L80
- ▶ Accessories: Stainless steel holder, clamping bracket, clamping holder L80

Star knob	No.
M6x25	10 3842571174

Material: Star knob: PA;
Thread, eye: Steel; non-rusting

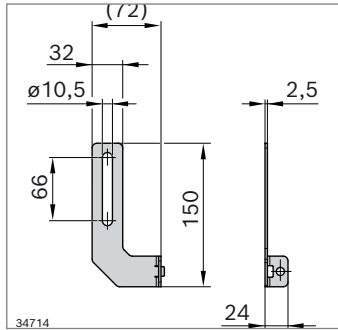
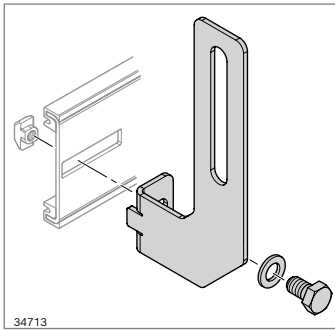

- ▶ Stainless steel holder for increased hygiene requirements with variable height and width adjustment
- ▶ Holder for fastening clamping holders C L80, D12 L80
- ▶ Slot for variable installation heights and use of one or two clamping holders
- ▶ Variable guide widths possible
- ▶ Accessories: T-nut for AL or STS, clamping bracket, star knob, clamping holder L80

Holder STS		No.
Set	10	3842571165
ZB	T-nut for AL	100 3842530285
ZC	T-nut for STS	20 3842546706

Material: Steel; non-rusting

Scope of delivery: Incl. fastening material (except for T-nuts)

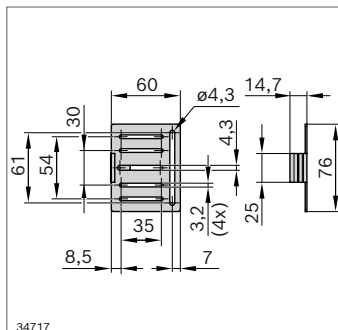
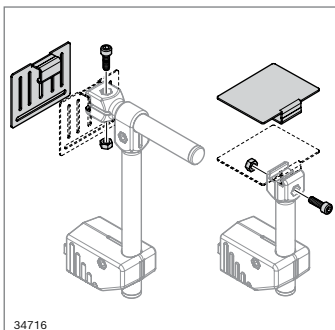
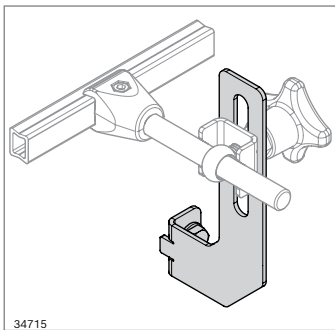

- ▶ Sensor support for mounting common sensors and reflectors with finished hole pattern
- ▶ Accessories: Clamping holder C L100 (**M**); clamping holder C (**N**); clamping head (**Q**), clamping holder C L80

Sensor support	No.
	3842571203

Material: Non-rusting steel 1.4301

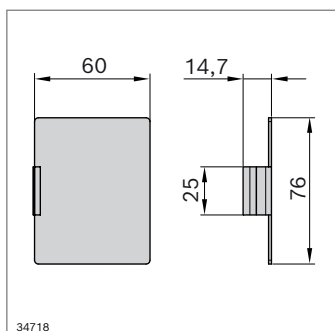

- ▶ Sensor support for fastening customized sensors and reflectors
- ▶ Hole pattern must be made as required
- ▶ Accessories: Clamping holder C L100 (**M**); clamping holder C (**N**); clamping head (**Q**), clamping holder C L80

Sensor support	No.
Variable	3842571204

Material: Non-rusting steel 1.4301

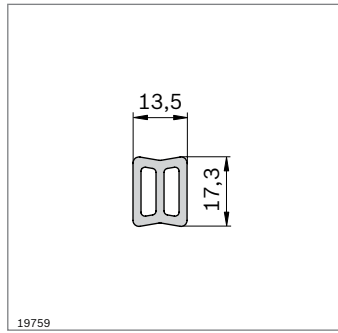
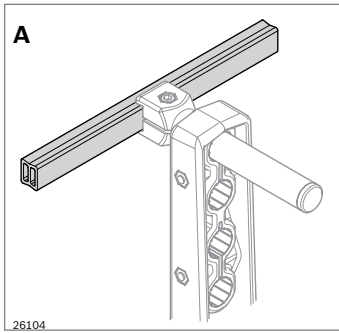

- ▶ Aluminum profile rail for robust lateral guides
- ▶ Holder distance: Max. 750 mm, less with accumulation pressure
- ▶ Accessories: Sliding rail narrow (**E**); sliding rail high (**F**); outer profile connector (**G**); inner profile connector (**H**); cover cap (**I**); clamping holder C L100 (**M**); clamping holder C (**N**); holder (**J**); clamping head (**L**); clamping head (**Q**)

Aluminum profile rail		L (mm)	No.
A	1 pc	200 ... 3000	3842993887/L
A	20 pcs	3000	3842538829

Material: Aluminum; natural, anodized

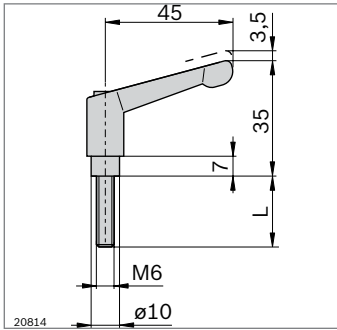

Clamping lever	L (mm)	No.
M6x25	25	3842528540
M6x40	40	3842528539

Material: Lever: Diecast zinc; black plastic coated
Screws: Steel; galvanized and black chromated



Sliding plate

Sliding plate for reliably bridging the conveyor trench between two parallel section profiles

14 mm

Drive	parallel	No
	offset	Yes

- ▶ Simple assembly thanks to pluggable screwed connection
- ▶ Depending on the product geometry, a small height offset of the sections may be necessary for a trouble-free product transfer. For this purpose, the 10 mm supporting brackets (3842572257) can be supported by spring plates (to be produced by the user).

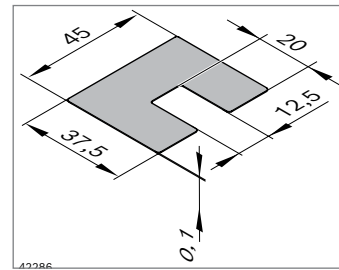

**Spring plate
(to be produced
by the user)**

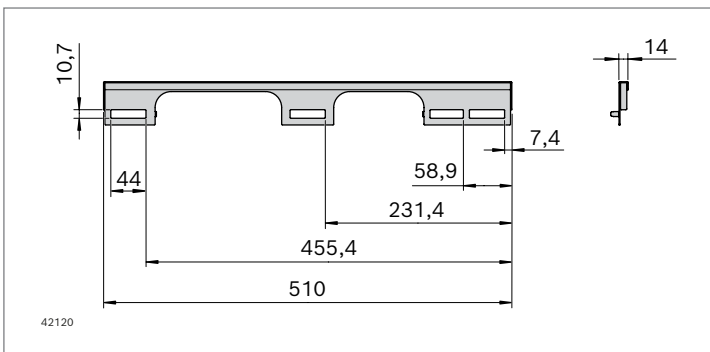

Sliding plate VFbelt

No.

14 mm

3842571248

Material: Non-rusting steel 1.4301

Scope of delivery: Incl. fastening material

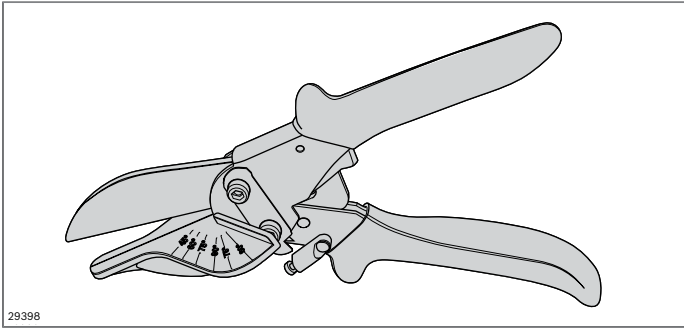

Tools

Miter cutter

The sliding rail can be easily and quickly cut to the correct length and angle with the miter cutter

Miter cutter		No.
	1	3842547982

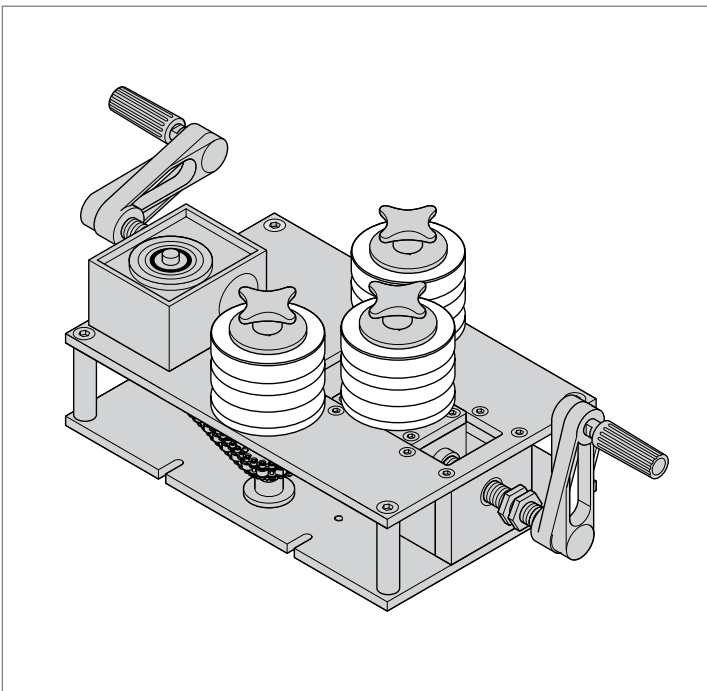

Bending tool for lateral guide

Crank-operated bending tool for bending profiles. Roller set adjusted to fit the profile rail to laterally guide the transported material. We recommend that you let your Bosch Rexroth distribution partner carry out the bending of lateral guides.

Bending tool for lateral guide		No.
A	1	3842528531

Scope of delivery: Bending tool without roller set

Accessories, required:

- Matching roller set (A, B, C)

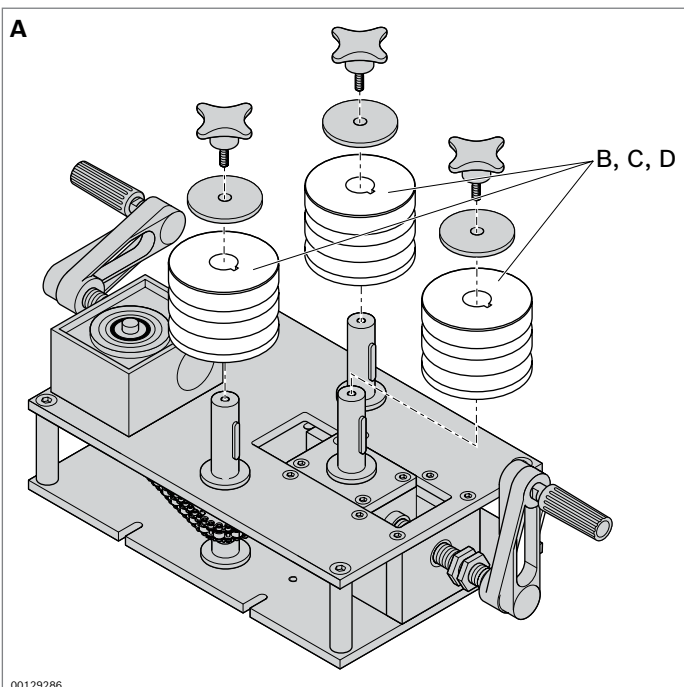

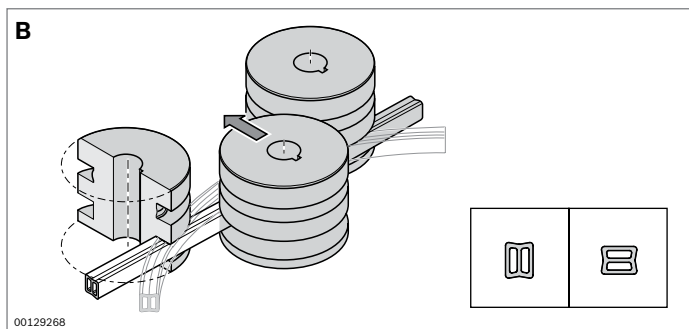

Roller set	☒	No.
B	1	3842538773

Roller set for bending tool for bending of aluminum profile rail 17.3x13.5

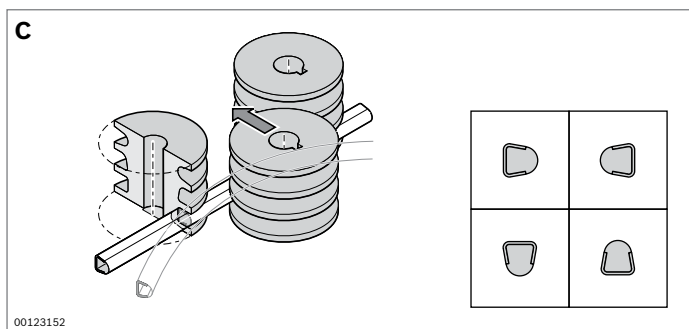

Roller set	☒	No.
C	1	3842529236

Roller set for bending tool for bending of PE profile rails 17x17.5 set in stainless steel

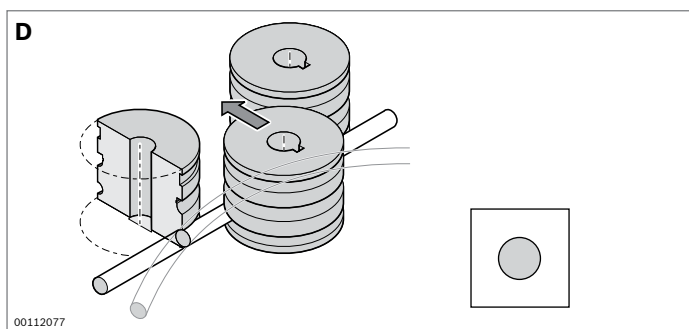

Roller set	☒	No.
D	1	3842533921

Roller set for bending tool for bending of stainless steel profile rail D12

Technical data

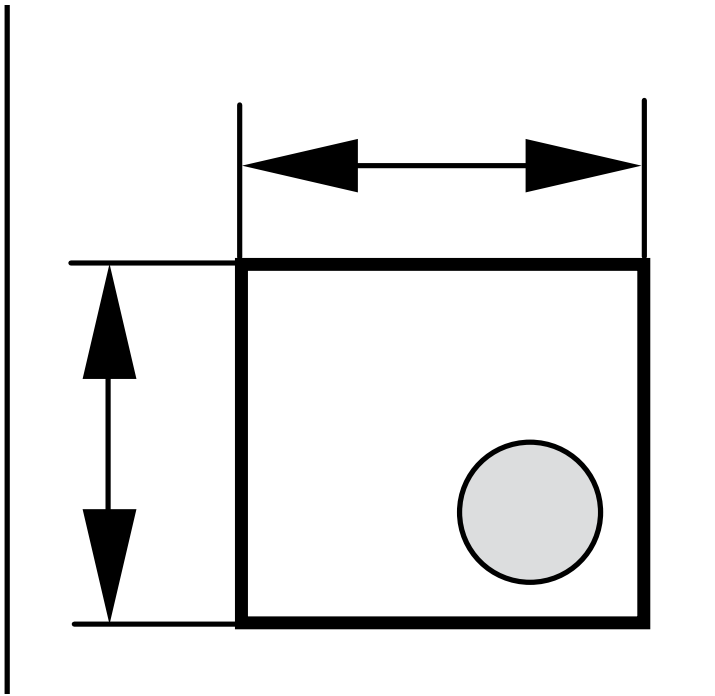

Ambient conditions

Abrasive ambient conditions:

When fitting the modular belt conveyor, pay special attention to the cleanliness of the sliding rails and the section profile. Metal shavings and builder's dust are very abrasive and can cause extreme wear!

During operation, general cleanliness of the system and its environment should be emphasized. This will prolong the service life of the sliding rails and the modular belt.

Dust and dirt particles, as well as chippings, salt, sugar, etc., are also very abrasive.

Using a modular belt conveyor system in critical environments is to be checked in each individual case. Please contact your Rexroth representative.

Temperature:

The application range for VarioFlow *belt* is 1°C to <60°C. At temperatures >40°C, the power of drive motors is decreased and the friction coefficients of plastic pairings increased. This results in a reduced tensile force of the modular belt.

Media resistance:

The materials used are resistant to most chemicals used in industrial applications, even in case of longer contact.

If in doubt, it is recommended that you ask the manufacturer of the cleaning agent whether the VF material (see material use) is resistant to the cleaning agent.

Due to resin in the lubricant, the modular belt may stick to the sliding rail after extended standstill. This can be avoided by continued (empty) running or by thorough end cleaning.

Humidity:

Operating the VarioFlow *belt* in dry rooms is not permitted; the relative air humidity must be at least 5%.

High-pressure cleaning:

High-pressure cleaning of the ball bearing areas of the modular belt conveyor (e.g. in the drive ...) is not permitted.

Loading and modular belt tensile force

The *BKBsoft* calculation software, included in the *MTpro* planning tool, assists you when designing and making the necessary calculations for your VarioFlow modular belt conveyor system.



MTpro with BKBsoft – the software for modular belt calculation

The *BKBsoft* calculation program that is integrated into the *MTpro* planning software allows quick and efficient calculation of the modular belt tensile force and the corresponding drive torque.

If the permissible modular belt tensile force or the drive torque of the gear motor is exceeded then the conveyor section must be examined to determine if the layout can be adjusted accordingly.

The required **tensile force on the modular belt** depends on the transport speed, the conveying length, the ambient and the operating conditions and is composed of several individual forces:

- ▶ Sliding friction force between unloaded modular belt and sliding rail
- ▶ Sliding friction force between loaded modular belt and sliding rail
- ▶ Sliding friction force between accumulated goods and modular belt
- ▶ Tangential components of the goods' and chain's force due to weight in inclining sections
- ▶ Sliding friction force in curves, between the chain and the inner sliding rail in the curve

The permissible drive torque of a gear motor is dependent on the transport speed (v), the operating mode (with/without FU), the ambient temperature and the line frequency.

If the permissible modular belt tensile force is exceeded during calculation, or if the drive torque calculated as necessary exceeds that of the selected gear motor, the following options are available:

- ▶ Dividing of the section into several modular belt conveyors.
- ▶ Shortening of the accumulation sections.
- ▶ Reduction of the speed (v) and use of a gear motor with a higher drive torque.
- ▶ Changing the operating conditions (e. g. the ambient temperature).

Modular belts

The technical data of the modular belt are included as basic data in the tensile force calculation.

Permissible section load of the conveyed goods q_{Fi} :

40 N/module series (25.4 mm)

Section load of the modular belt (own weight N/m)		
	Flat modular belt	Static friction modular belt
VFbelt 420	31.5	25.6
VFbelt 622	47.2	38.3

Permissible tensile force of the modular belt conveyor depending on the speed $F_{(v)}$ (N); max. 1250 N

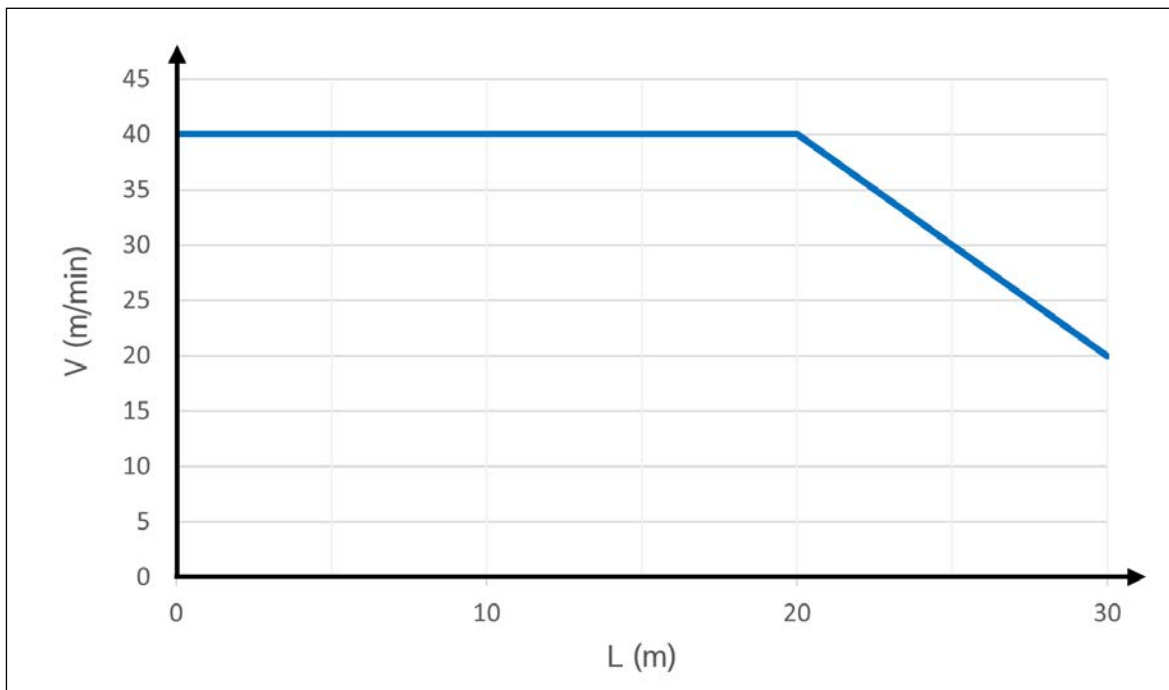

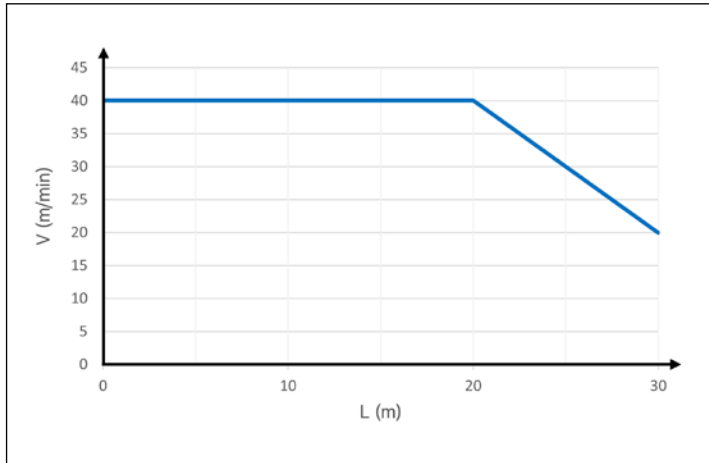

Dependence of the permitted velocity on the length of the conveyor section; $V_{(L)}$ (m/min); max. 40 m/min

Breaking force and modular belt elongation depending on the ambient temperature

The chain material (POM, PP) displays viscoelastic behavior just as every polymer does. As a result, the modular belt stretches during operation and it is necessary to check the modular belt length regularly and to shorten the modular belt if necessary.

Stick-slip effect

On conveyor systems with plastic chains, slipping known as the stick-slip effect (modular belt movement against the running direction) may occur in the rear transport area (before the return unit). This is the effect whereby belt sections on different running speeds in certain areas, ranging through to a brief standstill.

The effect is more pronounced the larger the distance from the drive. There is no stick-slip effect on the drive unit, as the modular belt is kept under optimal tension by the chain sprocket.

As a general rule, the stick-slip effect is mostly a visual and not a functional impediment for the continuous material flow. For certain applications, it is important to ensure that sections that may be susceptible to slipping are not used at points in the system with part positioning (e.g. printing).

Curve factor

Additional sliding friction forces occur in curves. These depend on the curve angle and are included in the *MT_{pro}* calculation of the required modular belt tensile force. Positioning of the curve has a direct effect on the tensile force. Therefore, the curve should be placed as close to the return unit as possible.

For design, the following restrictions must be taken into account:

▶ Horizontal curves

Maximum permissible total of all angles: 180°

Maximum permissible tensile force of the modular belt conveyor: 1250 N

▶ Vertical curves

Maximum permissible total of all angles: 30°

Maximum permissible tensile force of the modular belt conveyor: 450 N

▶ Combination

Maximum permissible total of all curves and angles: 2 vertical curves plus max. 90° horizontal curves

Maximum permissible tensile force of the modular belt conveyor: 450 N

Operating factor

The permissible modular belt tensile force depends on the number of start-up procedures per time unit.

Clocked operation leads to increased stress on the modular belt. The application factor is reduced when using a motor control such as a frequency converter. Intermediate values should be interpolated.

Start-up procedures/h	Operating factor c_B
0 ... 1	1.0
>2	0.83

Friction coefficient

Condition of contact surfaces	Flat modular belt (POM)	Static friction modular belt (PP)
Dry, clean = * No build-up of particles * Regular cleaning	0.2	0.25

Sliding friction factor between sliding rail and Modular belt Average value, based on the total runtime of the modular belt. With increasing runtime, the coefficient of sliding friction can increase.

Material	Condition of contact surfaces	POM
Plastic	Dry	0.25
	Water	0.25
	Refrigerant	0.12
	Oil	0.12
Paper	Dry	0.30
Glass	Dry	0.18
	Water	0.18
	Refrigerant	0.17
	Oil	0.17
Metal	Dry	0.26
	Water	0.26
	Refrigerant	0.11
	Oil	0.11

Sliding friction factors between material conveyed and flat modular belt Sliding friction factors typical for a product type. The actual factors must be determined by experimentation for a precise result.

³⁾ With sharp-edged parts, the value must be experimentally determined.

Effective modular belt and sliding rail lengths of components

For rough calculation of modular belt and sliding rail length

		Effective modular belt length (m)		Effective sliding rail length (m)			
		Size		Size		Size	
				L sliding rail		C sliding rail	
		420	622	420	622	420	622
Head drive		Σ: 1.8		Σ: 2.0	Σ: 2.5		
Return unit		Σ: 0.7		Σ: 0.8	Σ: 1.0		
Horizontal curve	30°	Σ: 1.8	Σ: 2.4	Σ: 5.4	Σ: 8.3	Σ: 1.8	Σ: 2.3
	45°	Σ: 2.4	Σ: 3.2	Σ: 7.1	Σ: 11.4	Σ: 2.3	Σ: 3.2
	90°	Σ: 4.0	Σ: 5.8	Σ: 12.5	Σ: 20.6	Σ: 4.1	Σ: 5.8
Vertical curve	5°	Σ: 0.7		Σ: 1.9	Σ: 2.3	Σ: 0.8	
	7.5°	Σ: 0.8		Σ: 2.1	Σ: 2.6	Σ: 0.9	
	15°	Σ: 0.9		Σ: 2.8	Σ: 3.3	Σ: 1.1	

Drive data

Definition of the basic principles of motor specifications

The specified performances, torques and revolutions per minute are rounded values and apply to:

- ▶ Operating time/day = 8 h (100% duty cycle)
- ▶ Uniform operation (continual), no, or very light, impacts in a rotational direction at 10 switching cycles/hour
- ▶ Installation positions and designs described in the catalog
- ▶ Maintenance-free gears with life-long lubrication,
- ▶ Ambient operating temperature 0 ... 60 °C. Gear unit with life-long lubrication for ambient operating temperature $\leq 0^\circ\text{C}$ available on request
- ▶ Protection class IP 55
- ▶ $f_{\text{mains}} = 50 \text{ Hz}$ constant
- ▶ $T_{\text{U}} = 20 \text{ }^\circ\text{C}$ for gearbox
40 °C for motors
- ▶ Installation altitude $\leq 1000 \text{ m}$ above sea level (NN)

- ▶ If the drive is overloaded, the service life is reduced.
10% overloading = 75% service life
20% overloading = 50% service life
- ▶ The gear motor (GM = 1) corresponds to the operating mode S1 (continuous operation)

In the case of other operating conditions, the achievable values may differ from those stated.

In the case of extreme operating conditions, please consult your distribution partner.

Motor data

Electrical connection requirements:

Connection to a 3-phase, 5-wire system (L1, L2, L3, N, PE); a connection plan is included in the terminal box.

All motors are equipped with a thermal contact*, which has to be connected to an overload switch-off.

All of the motors comply with protection class IP 55.

*) Bi-metal thermal contact, opening, tripping at $150\text{ °C} \pm 5\text{ °C}$.

Motor for push-on gearbox (with plug AT=S)



Gear motor (with plug AT=S)

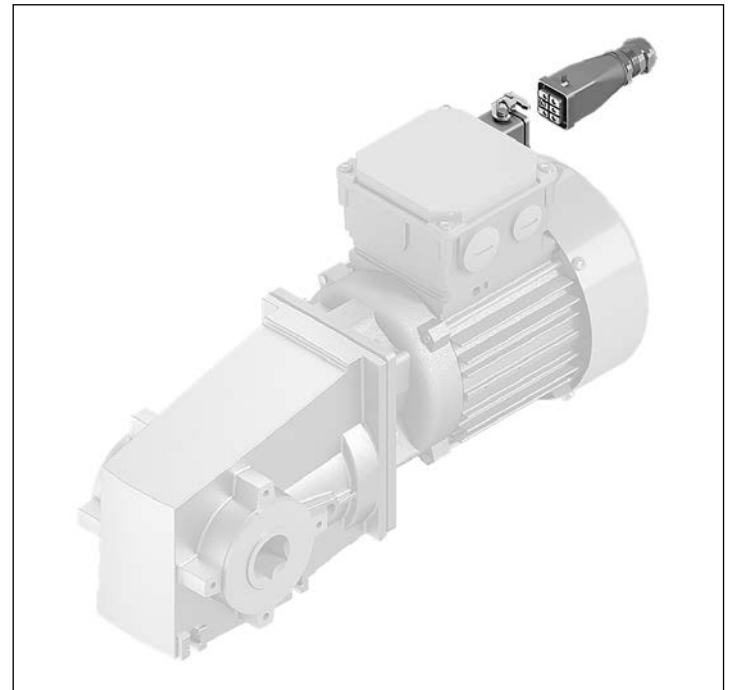

Country classification

	Europe	Switzerland	USA	Canada	Brazil	Australia	New Zealand	South Korea	China	India
Line voltage (3x....)	400 V	400 V	480 V ¹⁾	480 V ¹⁾ 575 V	220 V 380 V ³⁾ 440 V ¹⁾	400 V 415 V ²⁾	400 V 415 V ²⁾	220 V 380 V ³⁾ 440 V ¹⁾	380 V ²⁾	415 V ²⁾
Line voltage tolerance	±10%	±10%	±10%	±10%	±10%	±5%	±5%			±5%
Line frequency	50 Hz	50 Hz	60 Hz	60 Hz	60 Hz	50 Hz	50 Hz	60 Hz	50 Hz	50 Hz

¹⁾ ~ 460 V / 60 Hz

²⁾ ~ 400 V / 50 Hz

³⁾ ~ 400 V / 60 Hz

Motor data (GM = 1.3)

Performance data

Notice: Values are typical. Subject to change. See motor type plate for official data.

Please note the country assignment.

Voltage class	A	A	B	D
Circuit	Δ	Y	Y	Y
Voltage U at f = 50 Hz	200 V ±10%		400 V +10...-12 %	
Voltage U at f = 60 Hz	220 V ±10%	400 V ±10%	460 V +10...-12%	575 V ±10%

Motor type	IE3	Current consumption at rated power				Power factor cos φ	Power output at	
		I _N (A)	I _N (A)	I _N (A)	I _N (A)		(50 Hz) P (kW)	(60 Hz) P (kW)
524	x	0.65	0.35	0.32	0.24	0.6	0.09	0.1
624	x	1.15	0.65	0.55	0.45	0.66	0.18	0.22
634	x	1.65	0.9	0.85	0.65	0.6	0.25	0.29
714b	x	1.9	1.1	0.95	0.75	0.73	0.37	0.42
804a	x	3.1	1.8	1.45	1.15	0.65	0.55	0.63
716	x	1.3	0.75	0.6	0.62	0.68	0.18	0.22
734	x	1.9	1.05	0.95	0.72	0.74	0.37	0.42
734a	x	2.5	1.4	1.3	1	0.66	0.45	0.52
714a	x	1.65	0.95	0.85	0.65	0.60	0.25	0.29
716a	x	1.3	0.75	0.6	0.52	0.61	0.18	0.22
718b	x	0.95	0.55	0.48	0.38	0.6	0.12	0.14
814	x	3.1	1.7	1.45	1.1	0.69	0.55	0.63
824	x	4.1	2.25	2	1.6	0.66	0.75	0.86

Duty cycle ED:

All motors comply with S1 operation (continuous operation) and S3 operation (start-stop operation at 70%/10s) and are suitable for frequency converter operation.

Certification for the motor, cable and plug components:

IE3 motors: CE, cURUS, CCC

 Gear motor

3-phase motors

T _u (°C)	P _v / P _N
< 40	1 ¹⁾
45	0.95
50	0.90
55	0.85
60	0.8

¹⁾ Rated motor power (0.37; 0.25; 0.12 kW)

Rated motor power

The ambient operating temperature T_u influences the rated power P_N of the gear motors.

Transport and nominal speed v_N (GM = 1)

The transport speed v_N is specified for the rated power and frequencies of 50 Hz or 60 Hz.

The actual values v vary depending on:

- ▶ Tolerance of the standard motors
- ▶ Performance range of the motors
- ▶ Load on the conveyor section

Modular unit	50 Hz					Motor type	60 Hz					Motor type
	v_N (m/min)	$v^{1)}$ (m/min)	i	$n^{2)}$ (min ⁻¹)	M_N (Nm)		$v^{1)}$ (m/min)	i	$n^{2)}$ (min ⁻¹)	M_N (Nm)		
Head drive	5	4.7	60	11.5	94	718b	5.7	60	14	92	718b	
	10	9.7	60	23.3	97	714a	7.5	60	18.3	108	716a	
	12	12.2	47	29.2	114	714b	11.4	60	28.5	92	714a	
	15	15.5	37	37.1	91	714b	14.6	47	35.0	108	714b	
	20	19.7	29	47.7	71	714b	18.5	37	44.5	87	714b	
	25	24.9	23	60.0	57	714b	23.7	29	57.3	67	714b	
	30	30.1	19	73.5	46	714b	29.8	23	72.0	53	714b	
	38	38.1	15	90.0	38	714b	36.1	19	88.2	44	714b	

¹⁾ Transport speeds at other voltages/frequencies available on request

²⁾ Torque limited to 60 Nm by coupling

³⁾ Gear unit output speed

Motor connection

Motor connection with plug (AT = S), circuit diagram

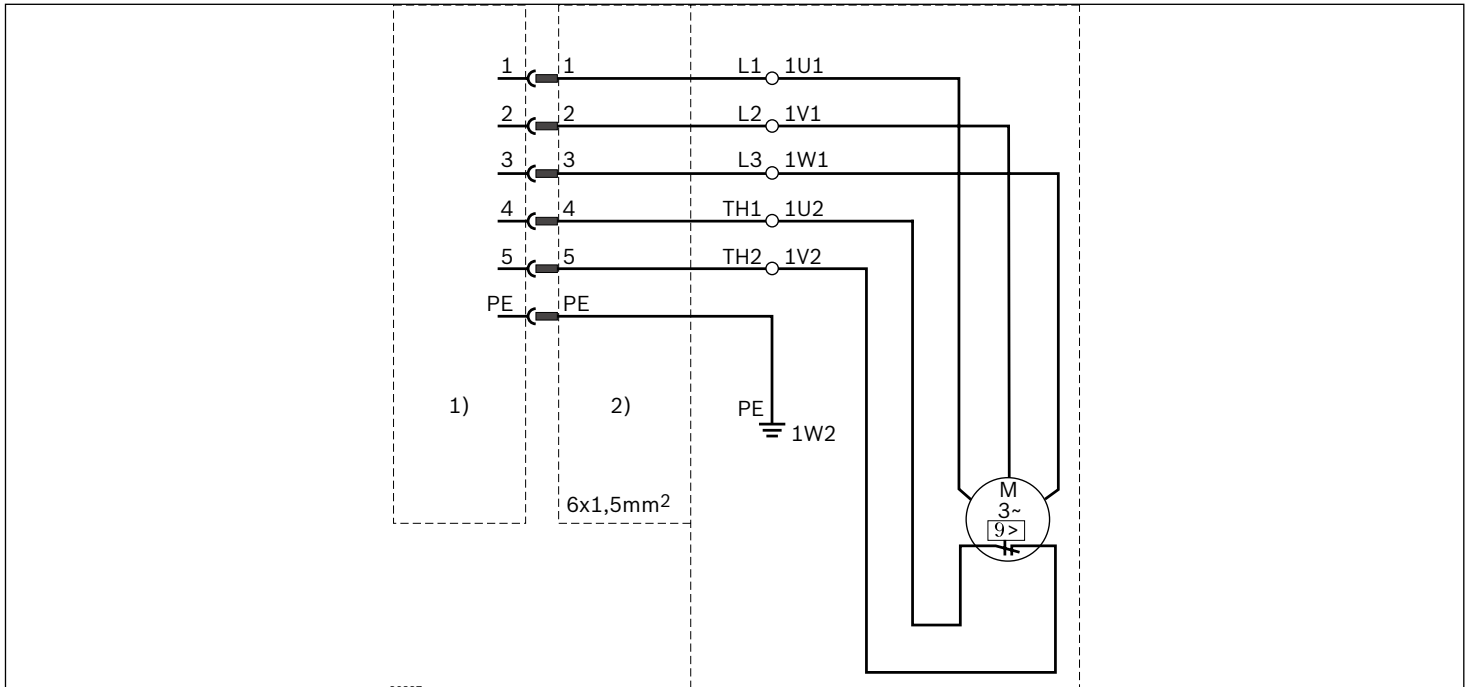

1) Connection cable side

2) Motor side

The push-in fitting consists of UL components.

Connection list

3~ motor connection terminals	Pin no.	Code
U1	1	L1
V1	2	L2
W1	3	L3
TW1	4	Th1
TW2	5	Th2
	PE	PE

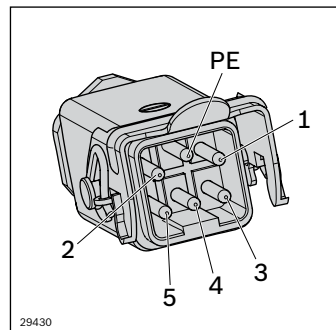

Motor side

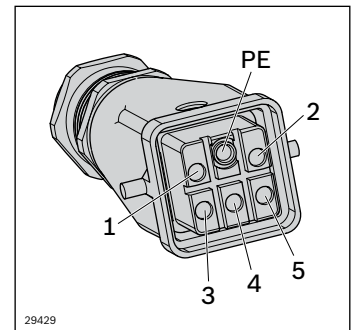

Connection cable side

Frequency converter motec 8400 (FU)

Drive spectrum of motors with frequency converters (FU)

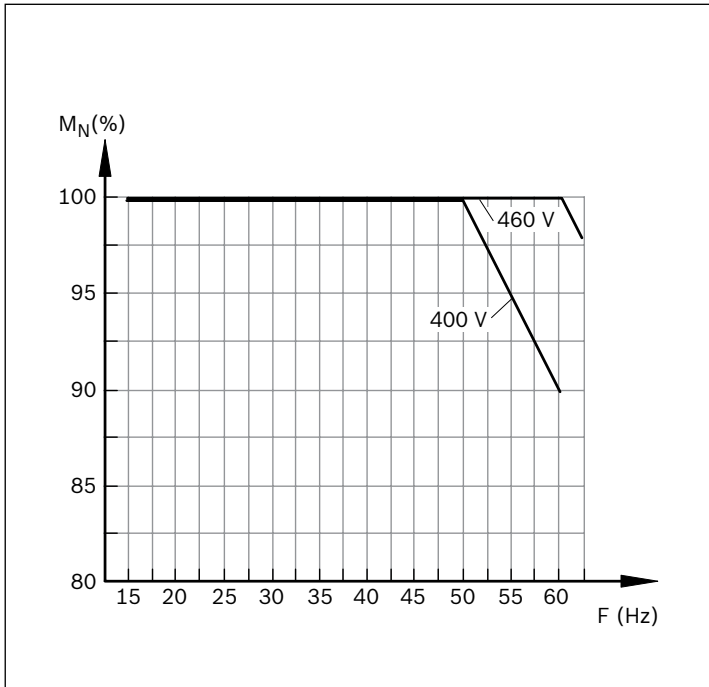

Technical information:

At rotating field frequencies of ≥ 16 Hz, the motor can be operated under normal operating conditions without an external fan. The motor's thermal conditions should be considered at rotating field frequencies of ≤ 16 Hz. In the range 16 ... 50 Hz or 60 Hz, the full torque is available. At rotating field frequencies of up to 10% above the nominal frequency, higher speeds with corresponding torque loss can also be realized.

Motor speed range (m/min) at 50 Hz	Min ¹⁾ (m/min)	Max ²⁾ (m/min)
5	2	5
10	3	11
12	4	14
15	5	18
20	6	23
25	8	29
30	10	36
38	12	44

¹⁾ Min corresponds to approx. 16 Hz supply frequency

²⁾ Max corresponds to approx. 60 Hz supply frequency

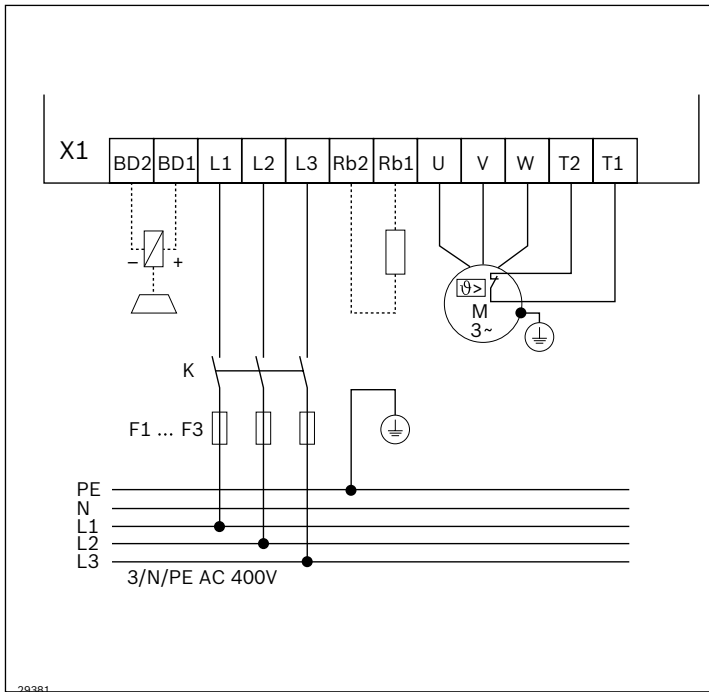

Frequency converter (FU) accessories

In order to operate a drive with a frequency converter (FU), the user needs to work out the minimum wiring for the internal and external voltage supply (see terminal assignment plan left).

Minimum wiring required for operation
 ----*)---- Additional wiring to change rotational direction

Ordering parameters for SEW motors (GM = 2)

The following ordering information is required if using gear motors from SEW-Eurodrive GmbH & Co, Bruchsal:

- ▶ Motor type
- ▶ Ratio
- ▶ Installation position
- ▶ Drive output position
- ▶ Terminal box position
- ▶ Cable entry (fig. 4)
- ▶ Motor voltage/frequency^{*)}
- ▶ Thermal class^{*)}
- ▶ Motor protection class^{*)}

^{*)} www.seweurodrive.com

Gear motors for line frequency $f = 50$ Hz

v_N (m/min)	Actual v_N (m/min)	Motor type	Ratio	Drive speed gear motor	N (kW)	M_{max} (Nm)
5	5.3	SA47 DRN71MS4/TF	128.10	13.00	0.25	90
7	7.3	SA47 DRN71MS4/TF	94.08	18.00	0.25	90
10	11	SA47 DRN71M4/TH	63.80	27.00	0.37	90
12	13.1	SA47 DRN80MK4/TH	54.59	32.00	0.55	90
15	15.9	SA47 DRN71M4/TH	44.22	39.00	0.37	90
20	21.6	SA47 DRN71M4/TH	32.48	53.00	0.37	67 / 60
25	28.6	SA47 DRN71M4/TH	24.77	70.00	0.37	52
30	34.7	SA47 DRN71M4/TH	20.33	85.00	0.37	46
38	43.2	SA47 DRN80MK4/TH	16.47	106.00	0.55	37
3 ... 21	2.2 ... 21.6	SA47 DRN71M4/MM05	54.59	5.3 ... 53.0	0.055 ... 0.55	69 ... 81

Gear motors for line frequency $f = 60$ Hz

v_N (m/min)	Actual v_N (m/min)	Motor type	Ratio	Drive speed gear motor	N (kW)	M_{max} (Nm)
5	5.3	SA47 DRN71MS4/TF	128.10	13.00	0.25	90
7	7.3	SA47 DRN71MS4/TF	94.08	18.00	0.25	90
10	11	SA47 DRN71M4/TH	63.80	27.00	0.37	90
12	13.1	SA47 DRN80MK4/TH	54.59	32.00	0.55	90
15	15.9	SA47 DRN71M4/TH	44.22	39.00	0.37	90
20	21.6	SA47 DRN71M4/TH	32.48	53.00	0.37	67 / 60
25	28.6	SA47 DRN71M4/TH	24.77	70.00	0.37	52
30	34.7	SA47 DRN71M4/TH	20.33	85.00	0.37	46
38	43.2	SA47 DRN80MK4/TH	16.47	106.00	0.55	37
3 ... 21	2.2 ... 21.6	SA47 DRN71M4/MM05	54.59	5.3 ... 53.0	0.055 ... 0.55	69 ... 81

Head drive, direct

Motor mounting	Installation position	Drive output	Terminal box
R	M2 (M1)	B	0°
L	M2 (M1)	A	180°

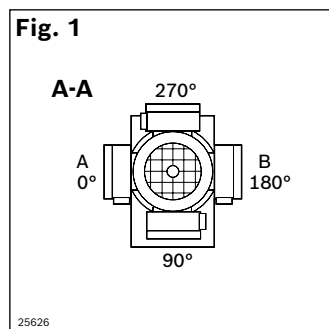
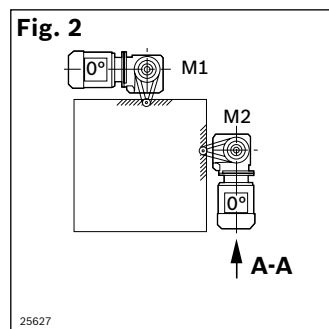
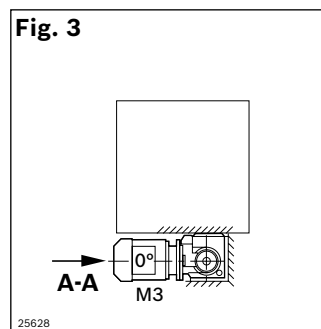
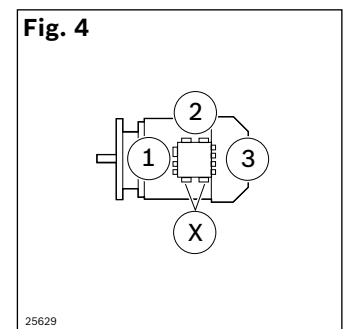
Position of terminal box**Installation position horizontal top/vertical****Installation position horizontal (above top edge chain)****Cable entry point**

Modular belt conveyor noise level

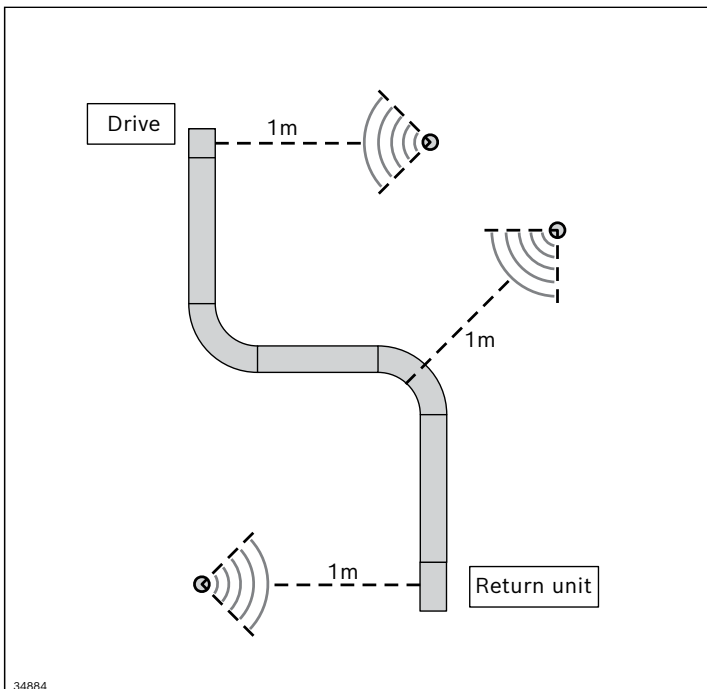

Generally, a higher speed will result in a higher noise level. The actual noise level depends on several factors:

- ▶ the product on the conveyor medium
- ▶ the modular belt type
- ▶ the installation location and fastening of the system (floor, ceiling, wall)
- ▶ the ambient conditions (vibrating objects, hard reflective walls, integrated systems of other makes, hall structures)
- ▶ the quality of system assembly and layout in accordance with the assembly instructions (sliding rail transitions, joints)
- ▶ the surrounding equipment
- ▶ conveyor layout and dimensions

Typical noise levels are shown in the illustration.

The noise level was measured with a distance of 1 m from the conveyor.

The measurement was taken in an industrial hall (ambient noise from approx. 50 dB (A) to 63 dB (A)).

Notice: Sound measurements carried out in an acoustic laboratory can be significantly lower. However, the sound levels determined in this case cannot be achieved under common production conditions.

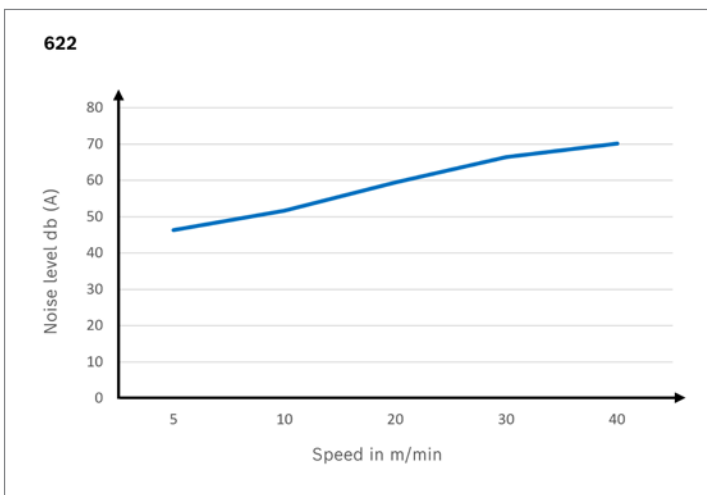

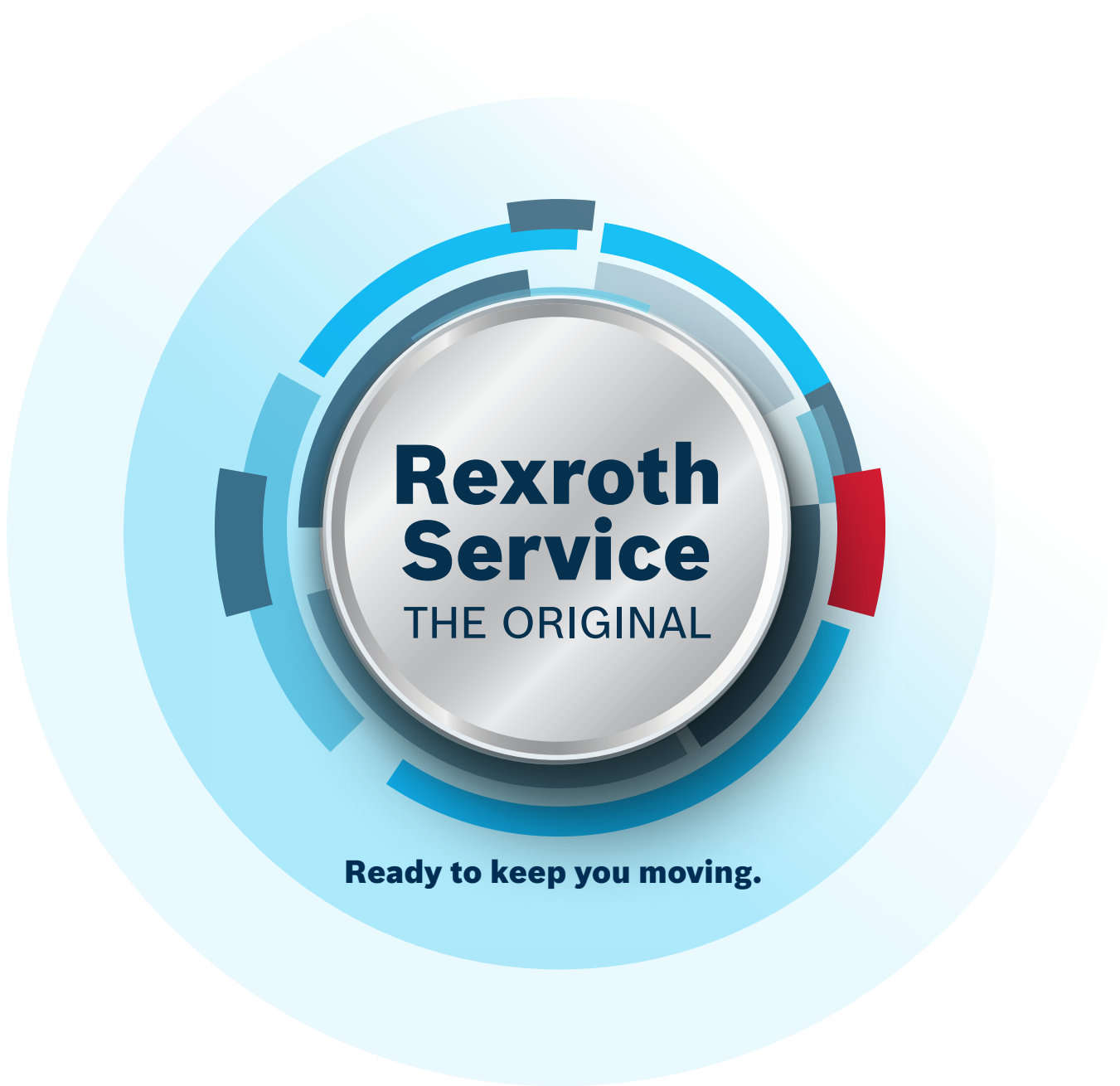

**IT'S ALL ABOUT
THE SERVICE**

Long service life. Rapid response.

Our goal is for you to benefit from your Bosch Rexroth solutions for as long and efficiently as possible. For all products in our current portfolio, but also for a period of up to ten years beyond the active sales phase, the availability of spare parts, repairs and technical support is guaranteed in our standard. Thereafter, we offer further support during an extended service phase. In many cases, this enables machine running times of more than 25 years, which are also secured through service agreements.

Our extensive service network comprising over 200 locations in 80 countries ensures a rapid response at all times.

Original quality. Maximum durability.

The Bosch Rexroth repair service analyzes, repairs and optimizes Bosch Rexroth components in guaranteed OEM quality. We use only new, original spare parts for repairs. As a result, the average lifespan of our repaired products is 5 times longer than with other workshops. In addition, our scalable material warranty can be extended up to 60 months.

You simply inform us about the urgency of the repair and provide the product type or serial number. You can then choose between a repair, REMAN or replacement service.

Emergency support. 24/7.

We know our technologies inside out. That is why we find the right solution as quickly as possible. Our repair service and hotline are available to you round the clock. They offer free technical support – from initial troubleshooting to dispatching a service specialist. You have the choice between standard, priority or emergency rush repair service.

Predictive.

To ensure that you can act instead of react, we offer you predictive services, such as preventive maintenance based on the product-specific history. And not just for our current product range: We have all global repair and delivery data to hand so that your system can continue to perform at its best, year after year. We support you by:

- ▶ Analyzing product availability
- ▶ Defining the best time for preventive maintenance
- ▶ And many more!



The data specified within only serve to describe the product. As our products are constantly being further developed, no statements concerning a certain condition or suitability for a certain application can be derived from our information. The information given does not release the user from the obligation of own judgment and verification. It must be remembered that our products are subject to a natural process of wear and aging.

Bosch Rexroth Corporation

Corporate Headquarters
14001 South Lakes Drive
Charlotte, NC 28273
Telephone (800) REXROTH
(800) 739-7684
info@boschrexroth-us.com
www.boschrexroth-us.com

Evolution Motion Solutions

13835 Senlac Dr, Farmers Branch, TX 75234
800-569-9801
info@evolutionmotion.com
www.evolutionmotion.com

Find your local contact person here:

www.boschrexroth-us.com/contactus

USA00192 (2025-02)
© Bosch Rexroth Corporation 2024
Subject to change without notice!

