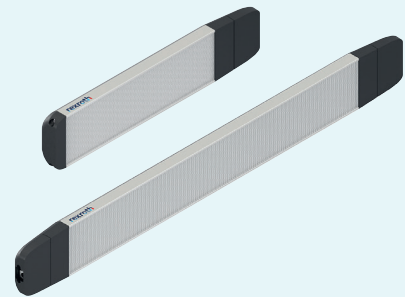


# Manual

# Production Systems

8.0



# System lamp LED basic – redesigned ergonomic lighting

**In comparison with the previous generation of LED system lamps: 50 % brighter. 20 % less energy consumption. And 50 % less investment thanks to the innovative tri-light configuration**



## DIMMABLE SYSTEM LAMPS – VERSATILE, COMPACT, SIMPLE

- +** **Universal:** Versatile thanks to the combined CE and UL/CSA certification
- +** **Flexible:** Dimmable – for packing stations to precision assembly to test workstations with requirements of more than 1000 lux
- +** **Compact:** New, attractive design for smaller interfering surfaces and greater employee acceptance
- +** **Safe:** Fastening via clips for quick and reliable assembly
- +** **Simple:** Reduced cabling effort thanks to a new plug-in system
- +** **Connected:** A DIM box centrally supplies and dims several lamps via a cable



**More details on page 2-32**



2

**Workstations**



3

**Grab containers**



4

**Swivel work chairs**



5

**Flow rack systems**



6

**EcoShape**



7

**EcoFlow**



8

**Material shuttles  
FiFo station**



9

**Case lifters**



10

**Infoboards**



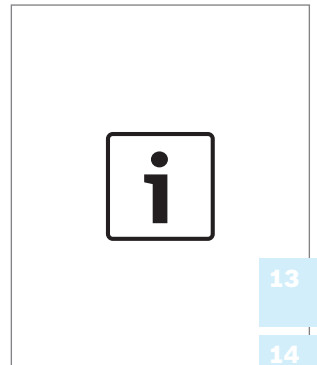
11

**ActiveCockpit**



12

**Components**



13  
14  
15

**Technical data  
Material numbers  
Index**



## SYMBOLS



You can easily configure customized products using the *MTpro* software



Delivered as individual components (not pre-assembled)



Delivered as components (pre-assembled)



Delivered assembled



Width of profile slot; accessories suitable for attaching in profile slot



Profile used in the frame



Conductive material version in accordance with DIN EN 61340-5-1, suitable for ESD-sensitive areas

## ORDERING INFORMATION

Slide rail	L (mm)	No.
	2000      10	3 842 554 750

<b>Packing unit</b>	= minimum order quantity – here: 10 pcs
Order:	1 x 3 842 554 750
Delivery:	10 x 3 842 554 750 (rounded up)
Order:	15 x 3 842 554 750
Delivery:	20 x 3 842 554 750 (rounded up)

D28L round tube	L (mm)	No.
50 pcs	6070	3 842 557 243

<b>Delivery unit</b>	= delivery quantity – here: 50 pcs
Order:	1 x 3 842 557 243
Delivery:	50 x D28L round tube
Order:	15 x 3 842 557 243
Delivery:	750 x D28L round tube



# Ergonomics, Lean Production and Connected Industry – the pillars of your success!

## OVERVIEW

<b>Manual Production Systems</b>	<b>1</b>
<b>Workstations</b>	<b>2</b>
<b>Grab containers</b>	<b>3</b>
<b>Swivel work chairs</b>	<b>4</b>
<b>Flow rack systems</b>	<b>5</b>
<b>EcoShape tubular framing system</b>	<b>6</b>
<b>EcoFlow linking elements</b>	<b>7</b>
<b>Material shuttles and FiFo station</b>	<b>8</b>
<b>Case lifters</b>	<b>9</b>
<b>Infoboards</b>	<b>10</b>
<b>ActiveCockpit digital communication platform</b>	<b>11</b>
<b>Components</b>	<b>12</b>
<b>Technical data</b>	<b>13</b>
<b>Overview of material numbers</b>	<b>14</b>
<b>Index</b>	<b>15</b>

Any company's economic success is built on top-quality products and services that result in the highest level of customer satisfaction. Given this fact, it is only logical that companies strive for continuous improvement across all levels of their operations.

Comprehensive success relies not only on lean, waste-free processes, but also on ergonomically designed work systems that allow workers to do their jobs with no waste. Good ergonomics serves to support the value chain and increase employee motivation.

The fusion of production IT and company IT, the synchronization of processes and machines that autonomously make decisions in real time all allow for efficient and customized manufacturing.

With MPS by Bosch Rexroth, you have a production system that places equal importance on ergonomics, lean production and networking. **WE MOVE. YOU WIN.**

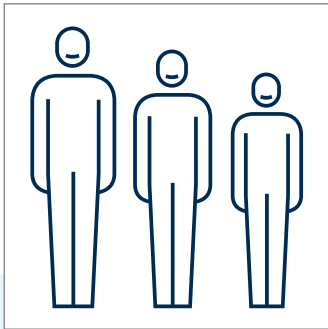
# For highly motivated employees, higher productivity and better quality

## Ergonomic workstation systems make work easier and keep workers healthier.

The benefits of ergonomically designed workstations: Increased motivation and satisfaction, higher performance, efficiency and work quality, as well as fewer absences due to illness. The bottom line: Ergonomics provides you with valuable benefits in the form of higher productivity, increased efficiency, and a decisive edge over the competition – thus ensuring lasting success for your company.



## 8 ERGONOMIC GROUND RULES FOR WORK SYSTEMS



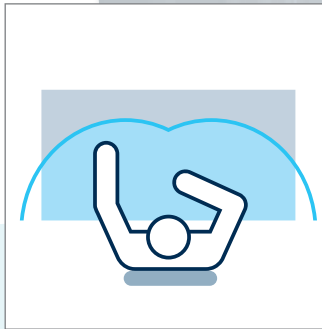
### Body height and working height

The optimum working height is based on the worker's body height and the type of activity to be performed. The average optimum working height for average requirements is 1125 mm for sit-down/stand-up workstations.



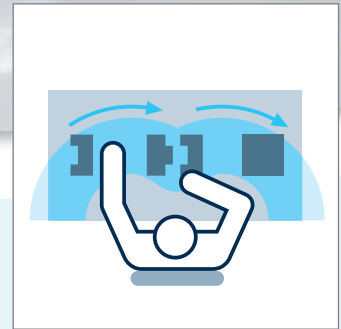
### Work area

The work area should always be between 800 mm and 1500 mm high. Working positions above heart height should be avoided, as should any work below 800 mm, as bending places an undue strain on the worker's body. Ideally, workers should perform dynamic activities with frequent shifts of exertion, such as switching between standing and sitting.



### Grab area

All containers, equipment, and operating elements must be easily accessible and located in the anatomical/physiological range of movement for the employee. Torso rotations and shoulder movements, particularly when under exertion should be avoided whenever possible.

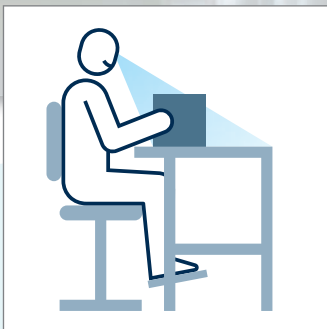


### Parts supply

All grab distances should be as short as possible. Grab containers and parts containers placed in direct reach of the employee are therefore ideal.

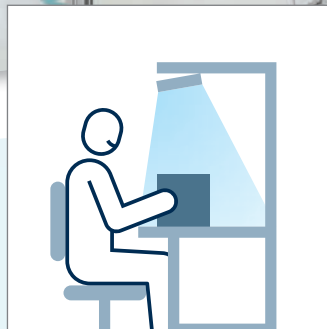


1



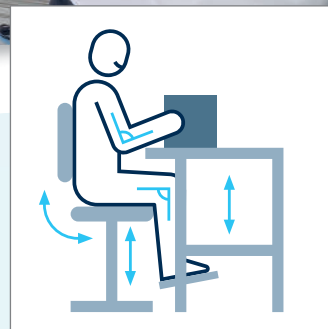
#### Vision areas

Unnecessary head and eye movements should be avoided. Maintaining objects at a uniform distance to the worker's eyes eliminates the need for refocusing. Avoid joining points that are not visible to the worker.



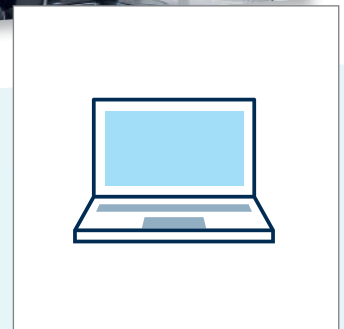
#### Lighting

Ideal lighting conditions prevent early onset fatigue, improve concentration and reduce the risk of errors. High contrasts, glare, and reflections should be avoided.



#### Adjustment of work equipment

Correct adjustment of the equipment serves to minimize required movements, thus reducing physical exertion and employee absences.



#### Planning aids

The ergonomic workplace design starts with planning. Available planning aids include the Ergonomics Checklist (3 842 523 943), the Planning Templates (3 842 542 286 /...287) as well as the MTpro software.

#### MTpro

Software for designing and planning workstations. For detailed information, see pages 1-9/10 or [www.boschrexroth.com](http://www.boschrexroth.com)

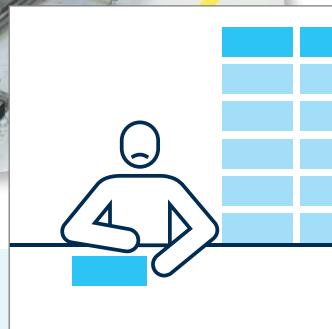
# Lean Production for greater productivity and shorter throughput times



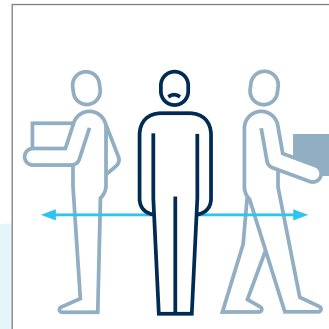
**Constantly growing cost pressure makes it necessary to permanently increase productivity in manufacturing. One central aspect is the detection and avoidance of waste (Muda).**

Waste refers to all process steps that do not directly contribute to adding value. Waste must be constantly avoided. In order to achieve this, the causes of waste must be identified and eliminated.

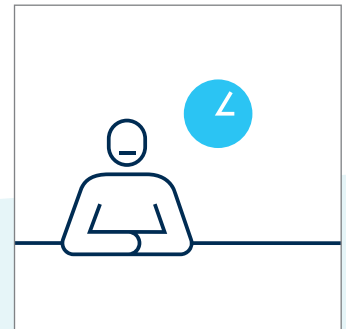
When analyzing processes, there is a difference between waste and added value. Next, waste is separated into two categories: Avoidable waste and unavoidable waste. Waste reduction, once initiated, is a continuous improvement process (Kaizen) that impacts all levels of the company.



**Overproduction**  
Overproduction occurs whenever more is produced than the customer ordered – or more than was planned. Overproduction requires additional storage and thus ties up capital.



**Superfluous movements**  
Superfluous movements occur whenever a worker needs to travel considerable distance to pick up materials or tools. Unnecessary travel costs valuable production time.



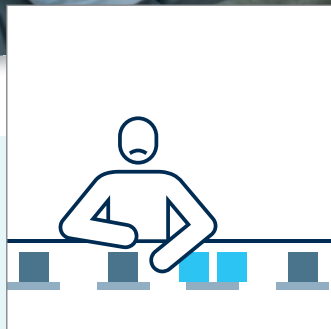
**Waiting times**  
Waiting times occur whenever the worker needs to wait for materials or for a process to end. During this time, the worker is tied up and does not contribute to adding value.

## 7 TYPES OF WASTE



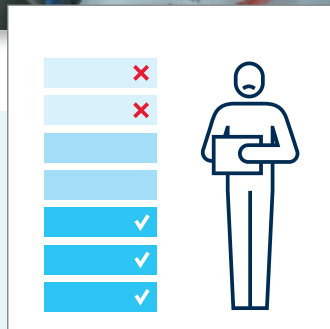
**Transports**

Transports occur whenever a forklift or lifting truck/crane is used to transport materials through production. Transports change the position of the product, but not its value.



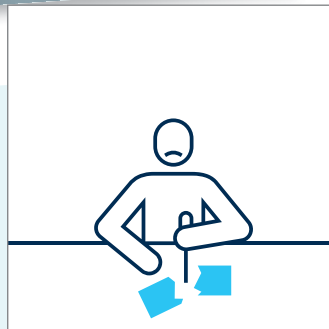
**Overprocessing**

Overprocessing occurs whenever production exceeds the required standard. More is invested in the process than is required to fulfill the function.



**Stocks**

High stocks in production, as well as in the raw material and finished goods warehouses, cost money. The stocks provide a feeling of security, but they also make the product more expensive.



**Faults**

If parts are not in the proper condition, they are classified as faulty. Faults require reworking and sorting, which results in increased costs.

# Connected Industry: The Factory of the Future is here!

It is a world of new possibilities – with more intelligence, flexibility, and cost efficiency.

Our aim is to take into account all aspects of a modern, lean and scalable production design. This results in holistic solutions that not only meet your current requirements – they open the door to the Factory of the Future too. With smart solutions and a global network, we are there for you anywhere in the world. Reliable, sustainable and highly mobile. **Now. Next. Beyond.**



<https://apps.boschrexroth.com/rexroth/en/factory-of-the-future/>



## Lean from pre-assembly to packaging – using Manual Production Systems (MPS)

- ▶ Ergonomic workstations for greater productivity
- ▶ Quicker assembly thanks to short grab distances
- ▶ Effective material supply for reduced stocks
- ▶ Case lifters reduce sickness rates
- ▶ Better employee information for increased transparency and quality

## Easily combining technologies with your production

- ▶ Networking of assembly stations and intelligent automatic Rexroth production assistants
- ▶ Standardized interfaces and web-based software
- ▶ Direct connection of back-end systems (ERP/MES) with ActiveCockpit for transmitting quality and cost values, for example
- ▶ More transparency thanks to status display of orders, deviations, personnel capacity or material flow

## From customer-specific solution to turnkey project

- ▶ Consulting, overall acceptance, training – around the world
- ▶ Comprehensive project planning and management, IT conception and integration
- ▶ Value stream-optimized layout based on extensive production experience
- ▶ Quality management/documentation incl. safety assessment of the overall system
- ▶ Project-specific warranty and service agreements

# Factory of the Future

Now. Next. Beyond.

1

## YOUR ADVANTAGES WITH REXROTH

- +** **Everything from a single source:**  
One automation partner, optimally tailored components
- +** **Shorter time to market:**  
Significantly reduced engineering outlay from the planning phase to commissioning
- +** **High flexibility:**  
Smart system solutions allow modular machine concepts which can be adapted quickly
- +** **Digital excellence:**  
A key user and supplier for Industry 4.0 – unique know-how in the Bosch Group
- +** **Global on-site service:**  
A presence in over 80 countries
- +** **Proven Rexroth quality:**  
Maximum precision and reliability for maximum system availability



### Rexroth Service – the key to productivity, maximum system availability and efficiency

- ▶ Throughout the entire life cycle of systems & machines
- ▶ Field service on site
- ▶ Spare parts & repairs: On-time delivery of proven quality
- ▶ Individual service contracts
- ▶ Training courses for set-up, maintenance and repair
- ▶ Technical support with fast, reliable handling



### Easy and user-friendly planning of assembly systems with MTpro

- ▶ Intuitive software – from planning to selection and configuration through to component ordering
- ▶ Simple creation and CAD export of layouts
- ▶ Direct insertion and linking via the snap function
- ▶ Comprehensive rules for assembly and configuration
- ▶ Automatically generated parts lists with order information

# MPS – a complete, ESD-protected system



**ESD is caused by electric charges that are generated by friction between various materials or by the influence of electric fields. These charges can generate up to 10,000 V.**

### Protection of ESD-sensitive components

Components sensitive to electrostatic discharge are known as ESDs (electronic static discharge-sensitive devices). Damage to these components generates considerable cost. Damage leads to an irreversible change in the device and a reduction in the ESDs' service life. Dangerous component voltages have an effect on ESDs sensitivity.

The most effective way to reduce ESD is to simply avoid electric charges or to conduct carried charges safely. Rexroth's ESD program, with ergonomically designed components, will assist you in designing a production system that avoids electrostatic discharge. With suitable materials and connection technology, the components in the ESD program are either electrostatically conductive or deflective and create a fully protected system.

To ensure and maintain the ESD-conductive properties, we recommend checking conduction resistance (R) at regular intervals after assembly.

Rexroth components fulfill the requirements for the protection of ESDs (DIN EN 61340-5-1). The individual national personal safety regulations must be observed during assembly and connection.

- **Defined grounding to an ESD-safe structure serves to make the entire system both safe and economical.**



# Plan assembly lines that are ergonomic, lean, fast, and safe with MTpro

## Careful and comprehensive planning is the only way to cost-effectively integrate ergonomics and lean production into the production system.

Ergonomic workplace systems help to keep workers both healthy and productive. What's more, they create the foundation for implementing lean production concepts and for improving the economic efficiency of companies.

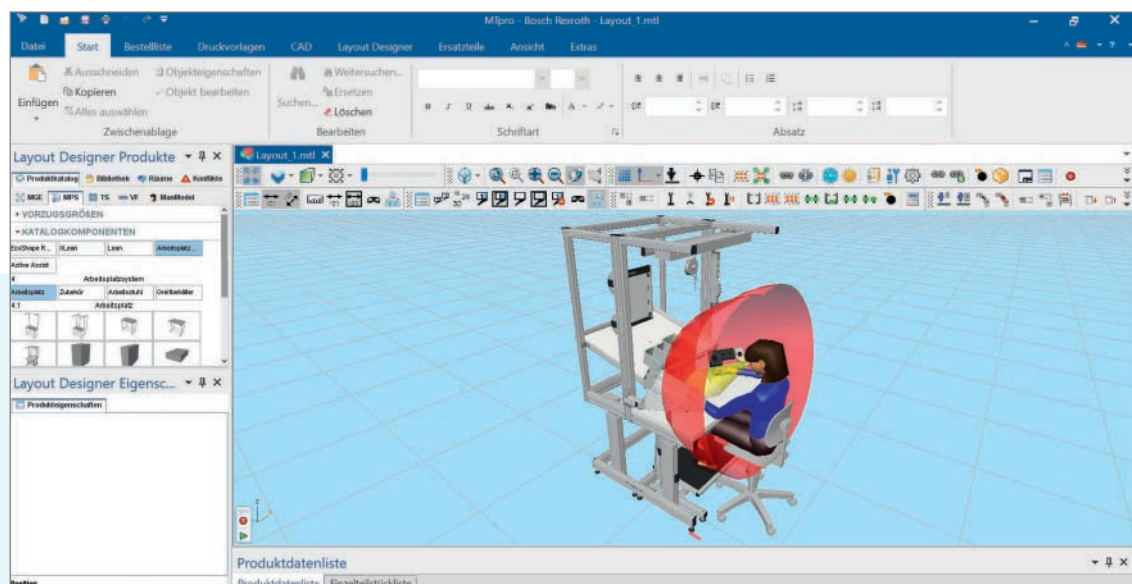
Adapting production systems to ergonomic and lean production requirements after the fact is cost-intensive. As product life cycles and unit production numbers continue to shrink, so does the time left for planning. This is where MTpro can provide valuable support. This planning software is designed with both needs in mind and offers good visualization as well as a CAD interface.

Users without CAD experience can use this software to design workstations, flow rack systems, manual linking sections and material shuttles with a click of the mouse. The user-friendly system allows users to create their designs by either using a guided parameter selection system for configurable products or by assembling various discrete components. A comprehensive set of rules covers the design logic, all product dimensions and the necessary information on accessories.

The "ManModel" is yet another ergonomic highlight. With this feature, MTpro can optimize designs for human use. Based on the dimensions of the human body, the ideal grab area, the proper distance from work equipment, and the proper angle of vision can be easily visualized and the production systems then designed.

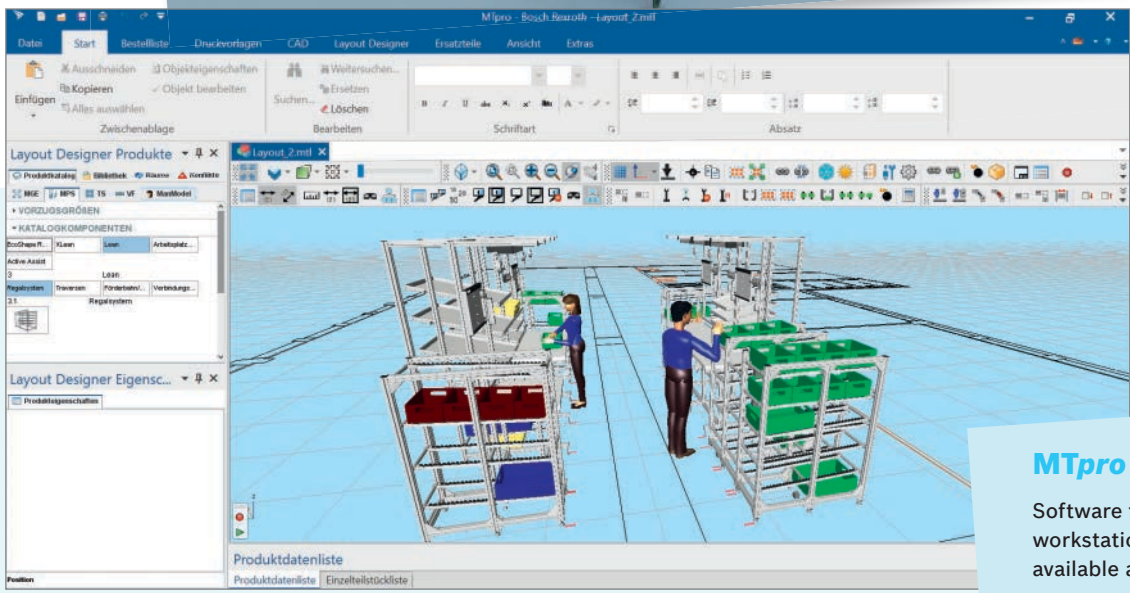
Users can then rapidly retrieve complete parts and order lists, price calculations and CAD data.

- **MTpro ManModels make it possible to integrate workstation ergonomics as early as the planning stage**





1



◀ **Multiple workstations are linked to form a production line that follows lean production principles**

**MTpro**

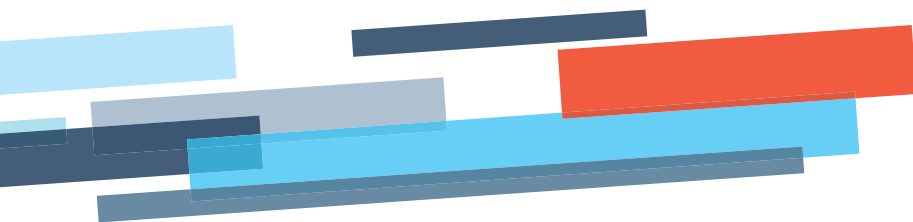
Software for designing and planning workstations. Detailed information is available at [www.boschrexroth.com](http://www.boschrexroth.com)



## Ergonomic workstations for greater productivity

**Workstation design must focus equally on the worker and on the product being manufactured – this is the only way to maximize productivity and profitability.**

Incorrect posture at the workplace can result in a waste of up to 40 % of a person's potential performance. The price paid for deficiencies in workstation design is measured in the high physical input needed to compensate for them. And such input is power and energy that would better be dedicated to the actual job at hand.



Add to this the fact that our society is steadily aging and it becomes clear that early investment in proper workplace equipment is essential for maintaining productivity and competitiveness over the long term. This is the only way to help prevent chronic conditions, such as back pain, from arising in the first place.

The first step is to examine the product and what is needed to assemble it and from there to define the work table dimensions and how material is to be supplied to the worker. Once this is done, the focus shifts to the worker and ergonomic design of the workstation begins. This will include looking at optimum tool positioning and information provision, but also at accessories such as footrests and proper lighting, key elements for an ergonomic, and hence efficient, workstation. In order to maintain a well-organized workstation and to securely stow small parts that are not always needed, the last step is to complement the 5S elements with storage cabinets.

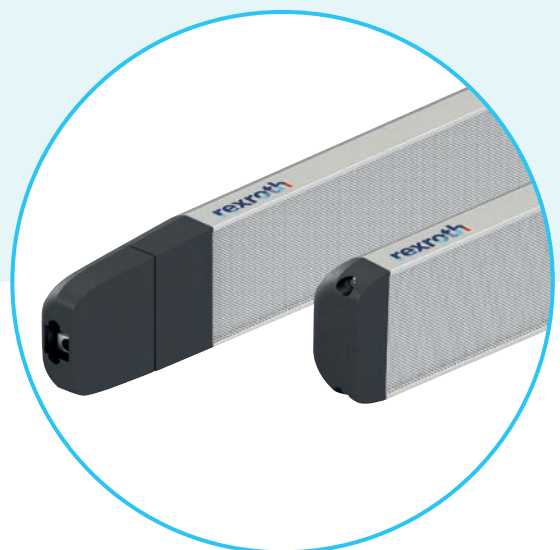
Rexroth's height-adjustable workstations go a step further than the competition by making the height of the material supply area and that of the working surface independently adjustable. The height of the workstation is determined by the worker's height and the product height, i.e., the work area. The height of the material supply area, on the other hand, is primarily determined by the worker's height, since their optimal grab area must be taken into account.

All workstations and workstation accessories are available in an ESD-conductive version.

Rexroth workstations are available as complete systems, as modules or as individual components. Variable dimensions and equipment features allow for customization and adaption to your specific requirements.

## WORKSTATION OVERVIEW

- 2-5** Height-adjustable workstation
- 2-13** Workstation
- 2-15** Table frames
- 2-16** Table tops
- 2-17** Material shelves
- 2-19** Rubber profile, footrests
- 2-22** Tool and parts supply
- 2-32** Lighting
- 2-42** Information provision
- 2-45** Cabinet systems
- 2-48** Accessories
- 2-53** ESD accessories
- 2-55** Ergonomic mat



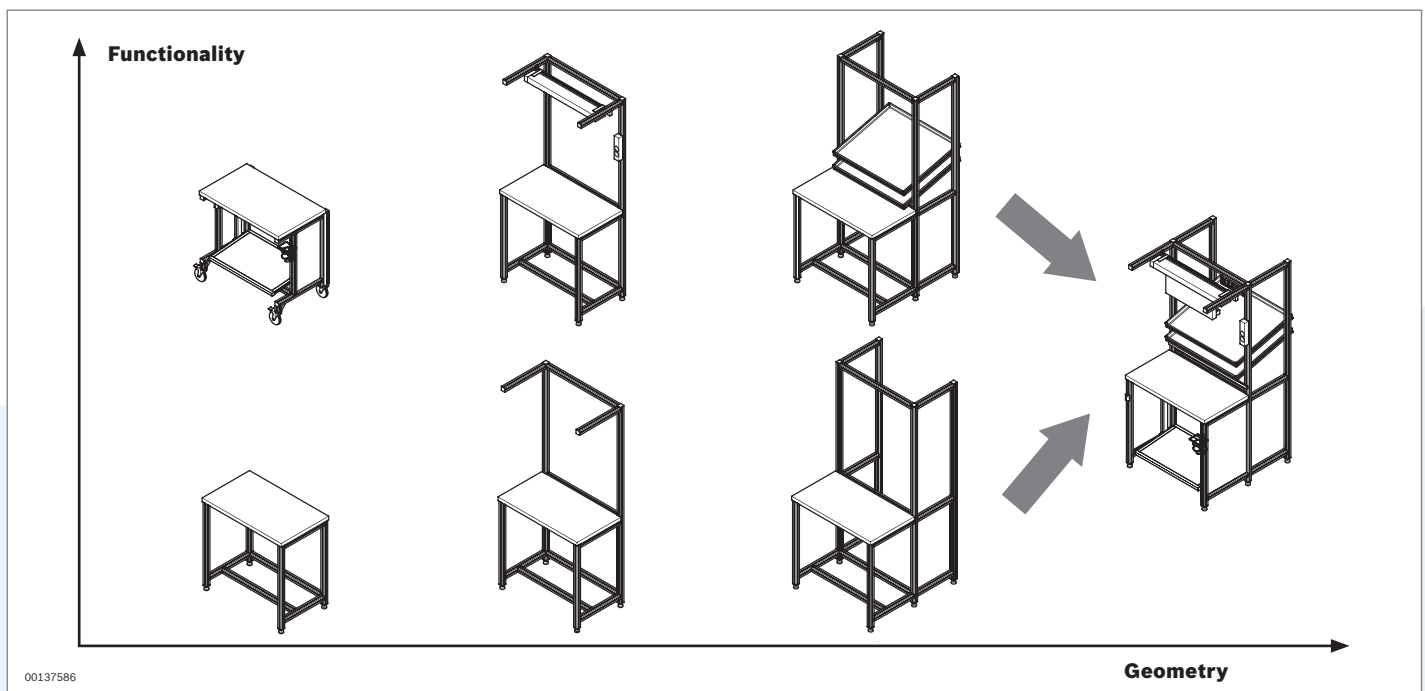
# Workstations

**Workstation design must take account of the product itself, the process required for that product, and the actual human being doing the work. The design must give equal priority to the minimization of process waste and to providing employees with an ergonomic work environment.**

This is why geometry and functionality are important in the layout of the workstation. The product being fabricated and the person doing the work are the benchmarks in defining the workstation height, width and depth as well as for positioning lighting and material supply equipment. Support accessories such as information boards are then added to ensure that the right information is available at the right place.

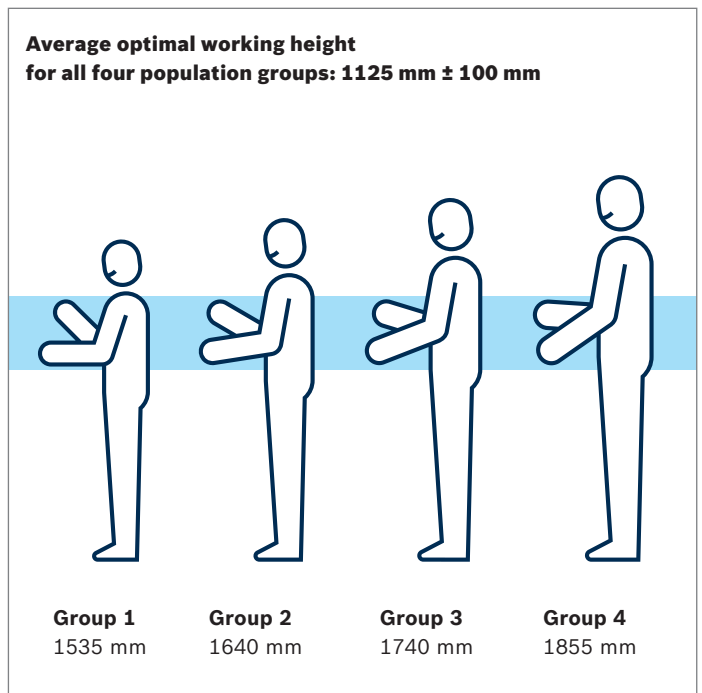
## Ergonomics

A basic facet of workstation design involves the encouragement of alternating, dynamic activity. Static activity inhibits blood circulation and oxygen supply to the muscles. Alternating physical exertion reduces stress on the employee and increases performance. Alternating exertion is seen, for example, where combined stand-up/moving or sit-down/stand-up workstations are integrated into the workflow.



Many workstations are used for multiple shifts. This means that these workstations need to be designed for employees of different height. The optimum working height is based on the body height range and the type of activity to be performed. If you take all body heights into consideration, the average optimum working height for average requirements is 1125 mm for sit-down/stand-up workstations. The ability to separately adjust the material feed height and the working height means that these height-adjustable workstations can be adapted to both different products and different workers. This is the key to creating an ergonomically optimized workplace.

Information on further aspects of ergonomic workstation design, such as the optimal grab area or recommended working heights, is available in our Ergonomics brochure (3 842 523 943).



39552

Requirements	Working heights (mm)			
	1	2	3	4
<b>High requirements</b>				
Visual inspection	1100	1200	1250	1350
Fine motor skills				
<b>Medium requirements</b>				
Visual inspection	1000	1100	1150	1250
Fine motor skills				
<b>Low requirements</b>				
Visual inspection	900	1000	1050	1150
<b>High requirements</b>				
Freedom of arm movement				
<b>Optimal working height</b>	<b>Ø = 1125</b>			

**MTpro**

Software for designing and planning workstations. For detailed information, see pages 1-9/10 or [www.boschrexroth.com](http://www.boschrexroth.com)



39552

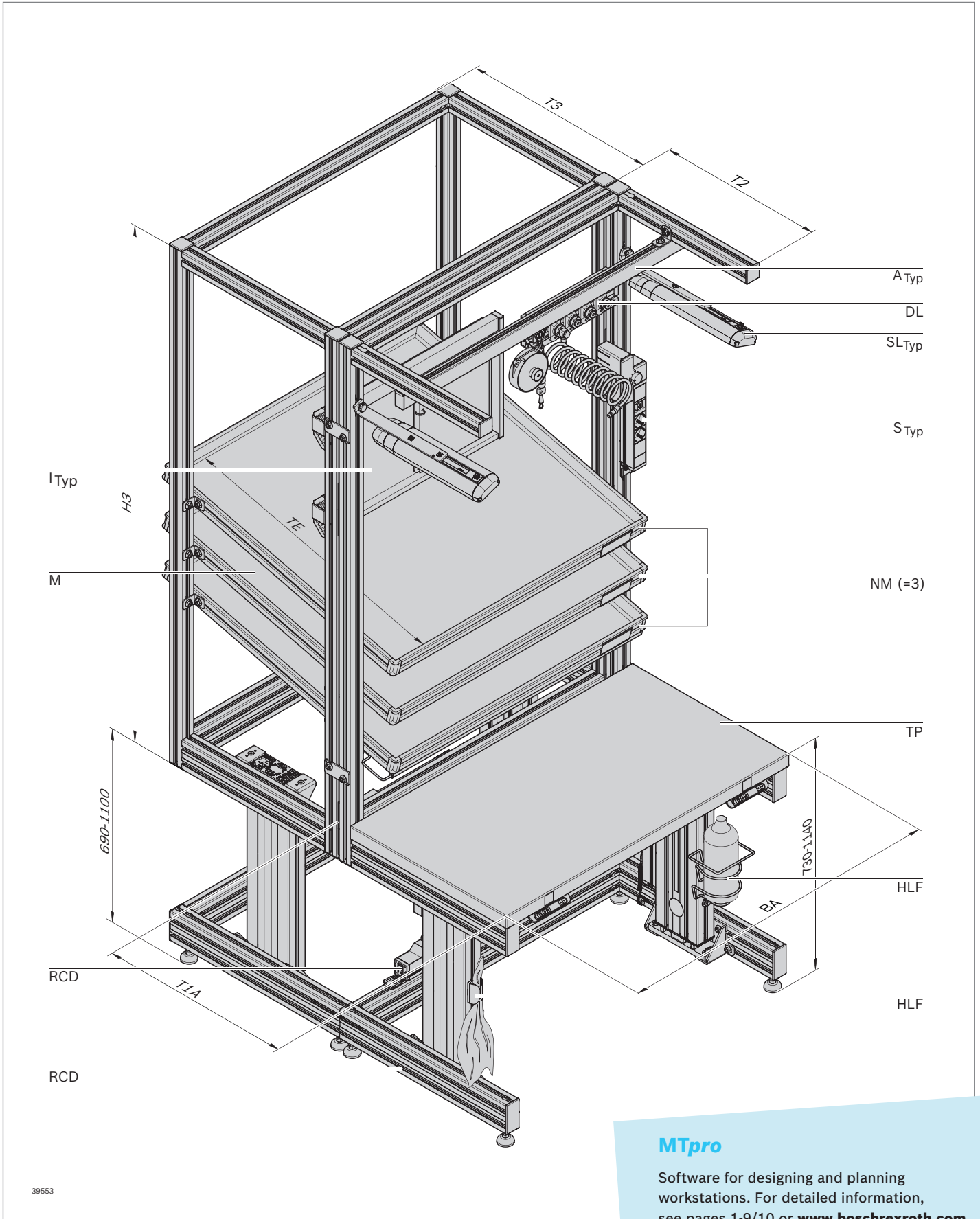
See technical data  
page 13-3

## Height-adjustable workstation



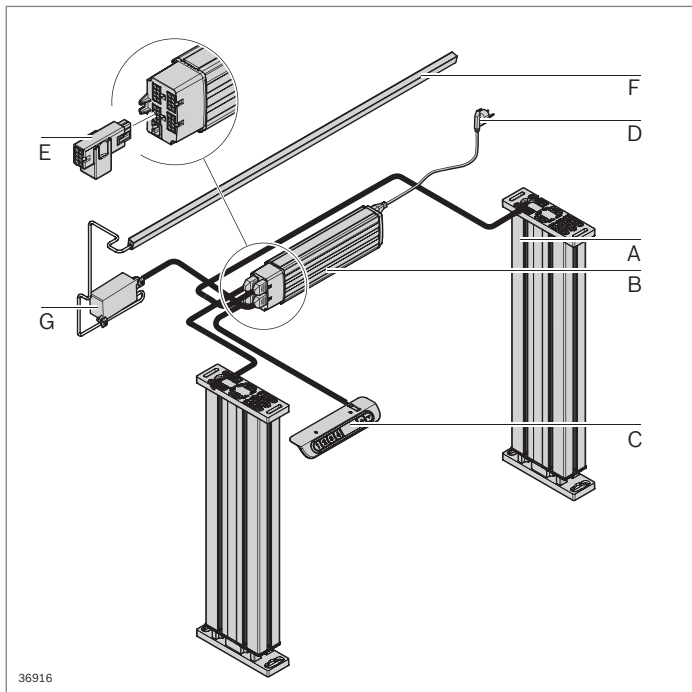
- ▶ Large number of adjustment options for high versatility
- ▶ Freely selectable geometry and functionality
- ▶ Height of material feeds and table tops can be adjusted independently of each other
- ▶ Available as ESD-conductive version
- ▶ Fully assembled or as a kit for self-assembly
- ▶ Allows for the addition of any desired modules, including cross ties and conveyor tracks as well as individual components

Height-adjustable workstation		3 842 998 350
<b>A</b>	Version	Disassembled, assembled
<b>ESD</b>	Conductivity	Yes, no
<b>LV</b>	Load version	No. of lifting modules
<b>BA</b>	Workstation width	640 ... 2000 mm
<b>H3</b>	Strut extension height	Up to 1500 mm
<b>T1A</b>	Workstation depth	Up to 1000 mm
<b>T2</b>	Bracket depth	Up to 800 mm
<b>TP</b>	Table top type	4 different table tops
<b>T3</b>	Accessory upright depth	Up to 800 mm
<b>NM</b>	No. material shelves	0 ... 4
<b>M</b>	Material shelf material	3 different material shelves
<b>TE</b>	Material shelf depth	520 ... 1100 mm
<b>E</b>	Suspension profile	With, without
<b>A<sub>typ</sub></b>	Type of hanger	With, without hanger Selectable spring pulls
<b>L</b>	Country version	D, F, GB, CH, CZ, USA/CAN
<b>RCD</b>	Residual-current device	Yes, no
<b>SL<sub>typ</sub></b>	Type of lamp	4 different lamps
<b>S<sub>typ</sub></b>	Type of socket	4 different sockets
<b>DL</b>	Compressed air strip	With, without
<b>I<sub>typ</sub></b>	Type of information board	7 different information boards
<b>HLF</b>	Cloth and bottle holder	With, without



**MTpro**

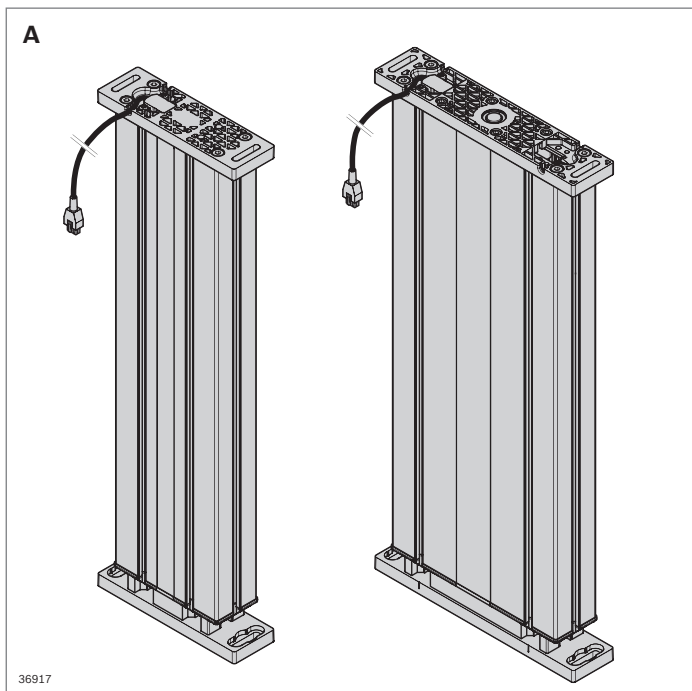
Software for designing and planning workstations. For detailed information, see pages 1-9/10 or [www.boschrexroth.com](http://www.boschrexroth.com)



### Height-adjustable workstation: Components

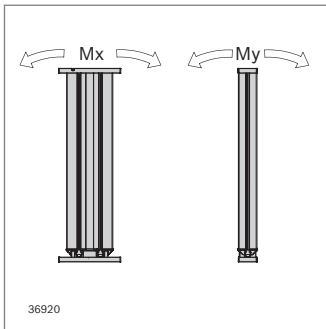
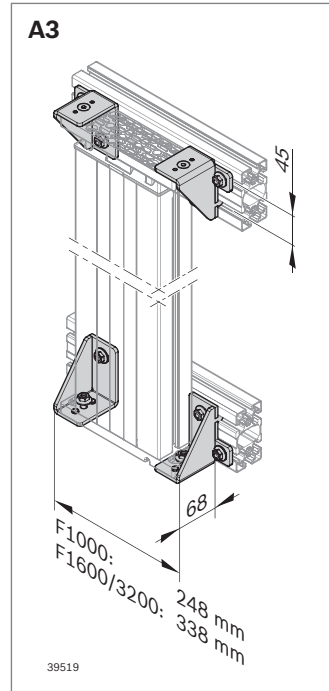
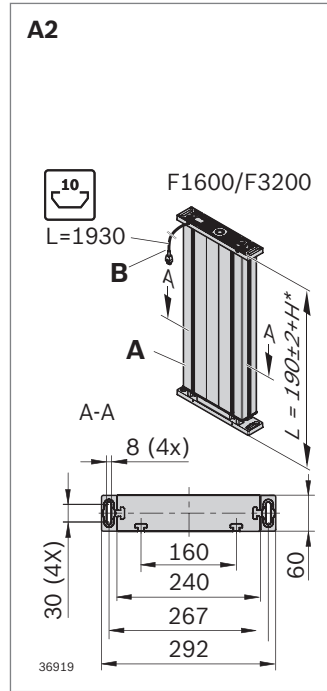
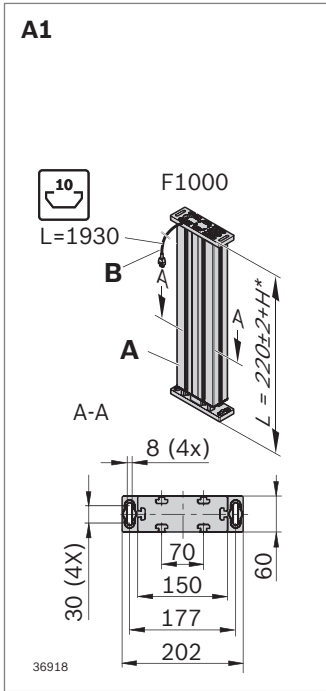
- A Lifting module
- B Control unit
- C Hand switch
- D Mains cable
- E Connection adapter (for DWS)
- F Pressure wave control strip
- G Pressure wave sensor (DWS)

See technical data  
page 13-3



### Lifting module (A)

- ▶ Three lifting lengths per variant
- ▶ Attachment by means of mounting plates at the face sides or using the integrated 10 mm slot
- ▶ Incl. connection cable; cable length: ~2 m
- ▶ Cable possible on the left or right side
- ▶ Diagonal cover cap prevents crushing risk
- ▶ All lifting modules are electrostatic discharge-enabled
- ▶ Mounting plates are connected in a conductive manner
- ▶ Attachment bracket set suitable for F1000, F1600 or F3200 lifting modules for lateral profile attachment (grid dimension 45 mm)



Technical data				
Load version	N	1000	1600	3200
Lifting length	mm	350 410 500	350 440 500	350 440 500
Lifting velocity	mm/s	25	18	9
Max. load, pressure	N	1000	1600	3200
Max. load, pulling	N	500	1200	1600
Perm. tilting torque Mx	Nm	300	500	500
Perm. tilting torque My	Nm	125	250	250

Load values, lifting systems				
No. of lifting modules		F1000	F1600	F3200
1	N	1000	1600	3200
2	N	2000	2600	5200
3*	N	3000	3600	7200
4**	N	4000	5200	10400

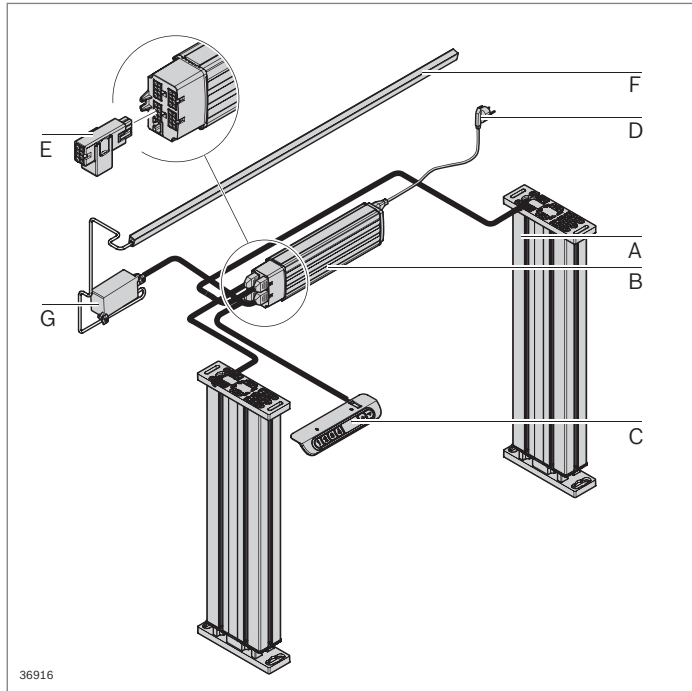
	Load version (N)	Lifting length (mm)	No.
<b>A1</b> Lifting module F1000 LIFT350MM	1000	350	<b>3 842 559 967</b>
Lifting module F1000 LIFT410MM	1000	410	<b>3 842 558 629</b>
Lifting module F1000 LIFT500MM	1000	500	<b>3 842 559 965</b>
<b>A2</b> Lifting module F1600 LIFT350MM	1600	350	<b>3 842 559 963</b>
Lifting module F1600 LIFT440MM	1600	440	<b>3 842 558 627</b>
Lifting module F1600 LIFT500MM	1600	500	<b>3 842 559 961</b>
Lifting module F3200 LIFT350MM	3200	350	<b>3 842 559 959</b>
Lifting module F3200 LIFT440MM	3200	440	<b>3 842 558 625</b>
Lifting module F3200 LIFT500MM	3200	500	<b>3 842 559 957</b>
<b>A3</b> Holding bracket lift modules*	1000 ... 3200		<b>3 842 564 145</b>
Holding bracket lift module set**	1000 ... 3200		<b>3 842 564 155</b>

\* In case of set-up without tilting torques; otherwise, the admissible load will be reduced

\*\* 2 control units synchronized via distributions

\* 2 x 2: 4 x including fastening material for 1 lifting module; weight: 1.8 kg; material: Steel, galvanized

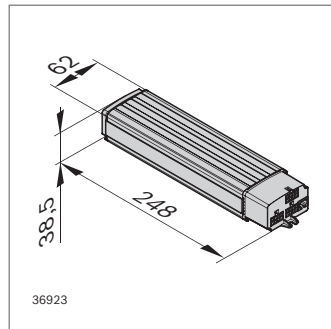
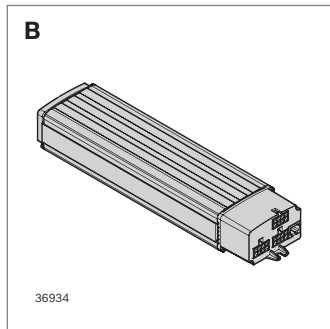
\*\* 2 x 20: 40 x for 10 lifting modules without fastening material



## Height-adjustable workstation: Components

- A Lifting module
- B Control unit
- C Hand switch
- D Mains cable
- E Connection adapter (for DWS)
- F Pressure wave control strip
- G Pressure wave sensor (DWS)

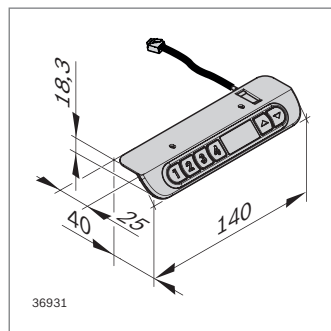
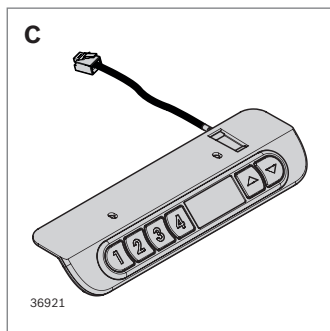
See technical data  
page 13-3



### Control unit (B)

- ▶ Control for synchronization of 1, 2, or 3 lifting modules in parallel operation
- ▶ Duty cycle: 10% (= 2 min ON, 18 min OFF, with max. load. With partial load correspondingly longer.)

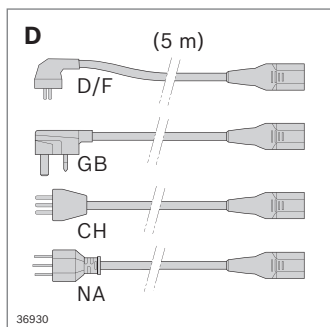
Scope of delivery incl. fastening material



### Hand switch (C)

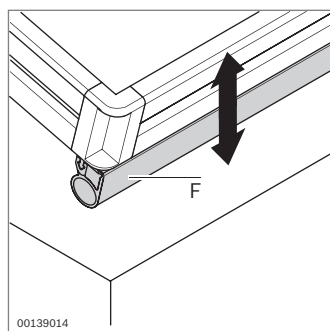
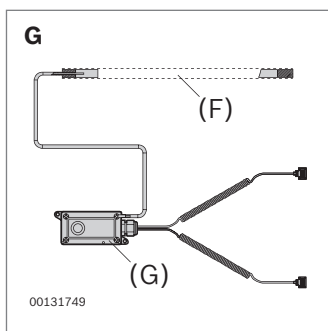
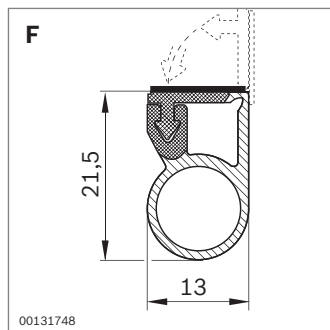
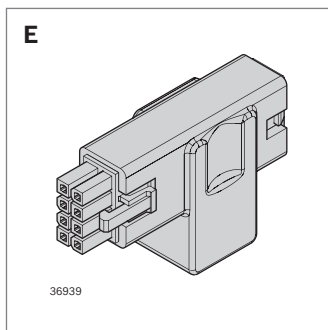
- ▶ For operating the controller, with push button for height adjustment and 4 memory buttons to store the different positions, with display
- ▶ Cable length: ~ 1.8 m

Scope of delivery incl. fastening material



### Mains cable (D)

- ▶ For connection to power mains



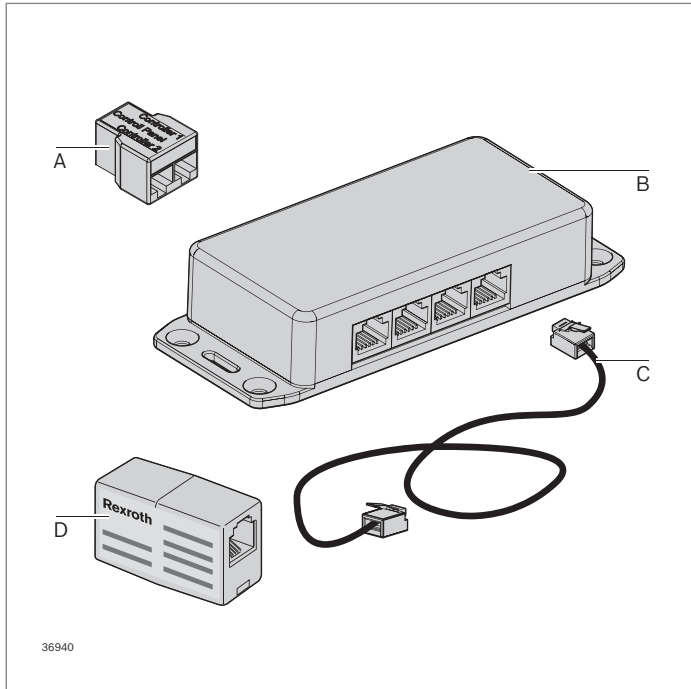
### Connection adapter (E)

- ▶ Between lifting module and control for the connection of a pressure wave control strip (F) (only required once, also for systems with distributors)

### Pressure wave control strip (F), pressure wave sensor (G)

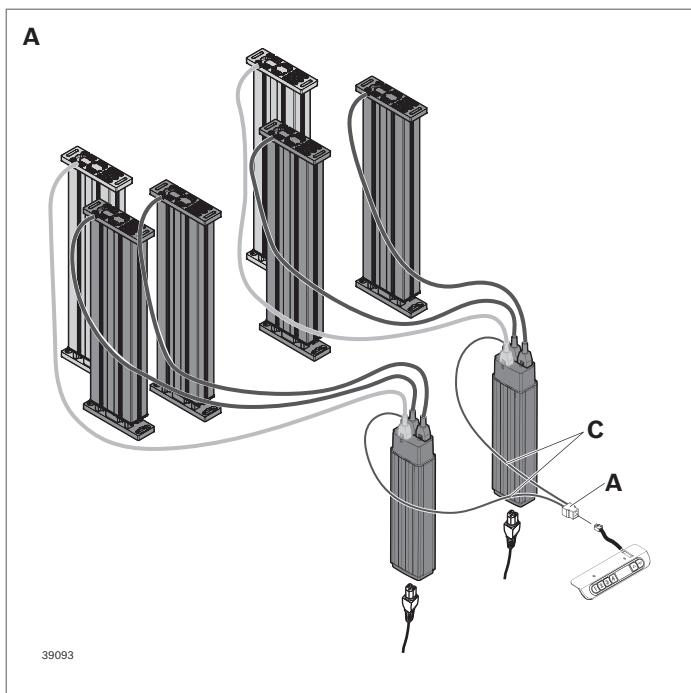
- ▶ A pressure wave control strip (F) can be connected to the control unit (B) to protect against mechanical collisions. Even if only slight pressure is applied to the pressure wave control strip, the pressure wave sensor (G) sends a signal to the control unit and the lifting modules move 25 millimeters in the opposite direction. The pressure wave control strip has a self-adhesive rear side and can be individually shortened.
- ▶ The pressure wave sensor (G) can be connected to up to 2 control units.

		Load version (N)	Voltage (V)	Length (m)	No.
<b>B</b> Control unit F1000	EU	1000	230		3 842 559 921
	NA	1000	120		3 842 559 931
Control unit F1600	EU	1600	230		3 842 559 922
	NA	1600	120		3 842 559 932
Control unit F3200	EU	3200	230		3 842 559 923
	NA	3200	120		3 842 559 933
<b>C</b> Hand switch					3 842 559 940
<b>D</b> Mains cable	D/F			5	3 842 559 950
	GB			5	3 842 540 952
	CH			5	3 842 540 197
	NA			5	3 842 559 954
<b>E</b> Connection adapter					3 842 559 948
<b>F</b> Pressure wave control strip				2	3 842 540 129
<b>G</b> Pressure wave sensor					3 842 540 130



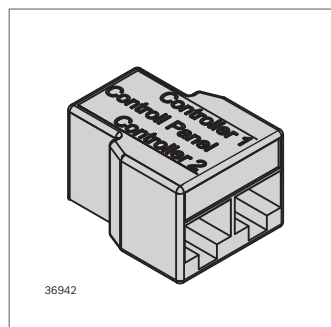
### Optional accessories

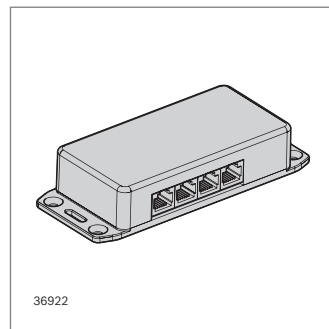
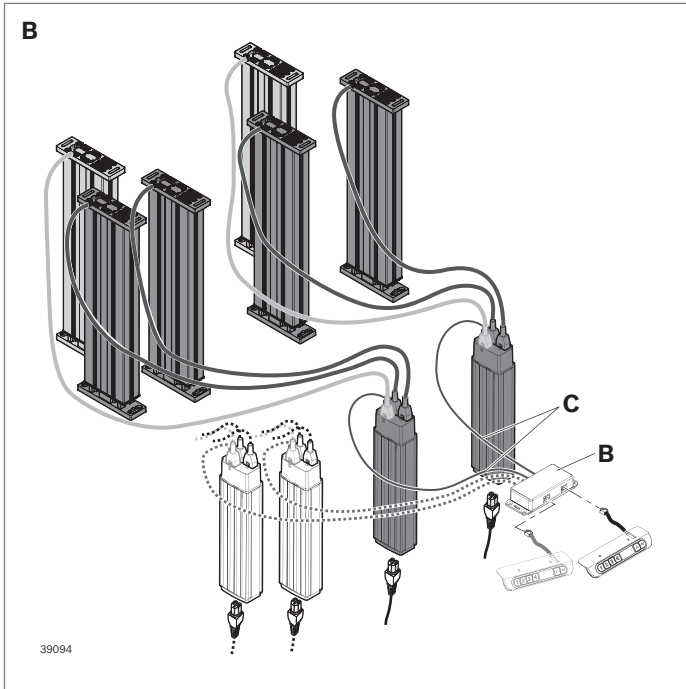
- A Distributor, economic
- B Distribution, basic
- C Connection cable
- D Plug connector



### Distributor, economic (A)

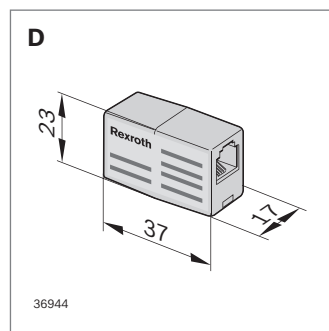
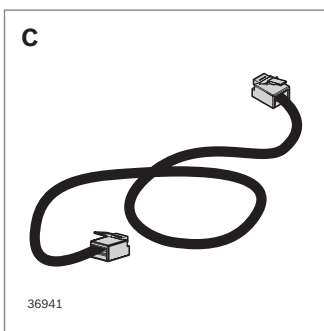
- ▶ Adapter for the synchronization of 2 control units
- ▶ Synchronization of a maximum of 6 lifting modules





#### Distributor, basic (B)

- ▶ Box for connection of up to 4 control units and 2 hand switches
- ▶ Synchronization of a maximum of 12 lifting modules



#### Connection cable (C)

- ▶ For the connection between the distributor and controls or for the extension of the hand switch cable

#### Plug connector (D)

- ▶ Coupling to connect two connection cables or to connect one hand switch cable and one connection cable

	Length (m)	No.
<b>A</b> Distributor, economic 1x2		<b>3 842 559 945</b>
<b>B</b> Distributor, basic 2x4		<b>3 842 559 946</b>
<b>C</b> Connection cable	0.9	<b>3 842 559 942</b>
	2	<b>3 842 559 944</b>
<b>D</b> Plug connector		<b>3 842 559 943</b>



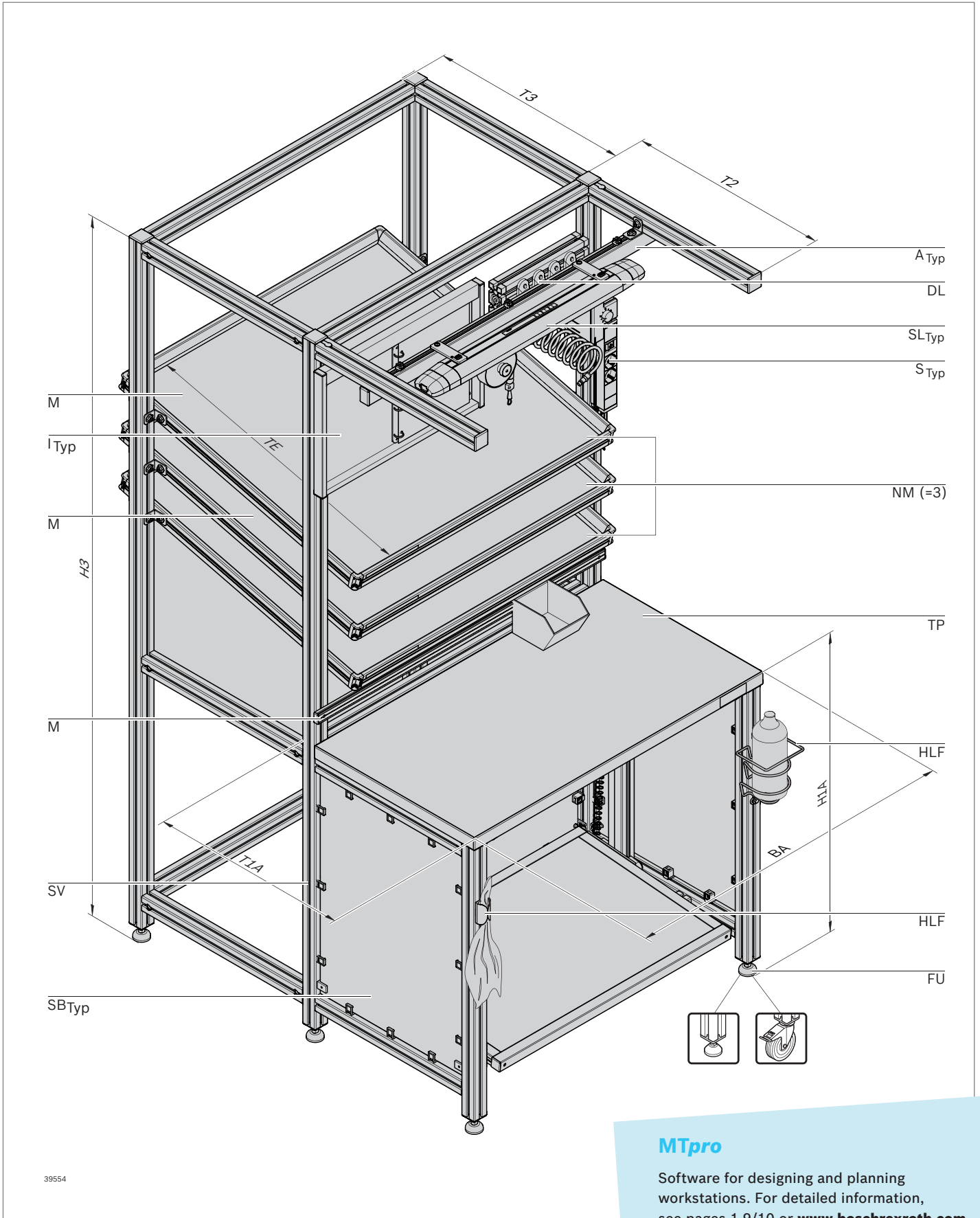
## Workstation



- ▶ Large number of adjustment options for high versatility
- ▶ Freely selectable geometry and functionality
- ▶ Available as ESD-conductive version
- ▶ Fully assembled or as a kit for self-assembly
- ▶ Allows for the addition of any desired modules, including cross ties and conveyor tracks as well as individual components

See technical data  
page 13-3

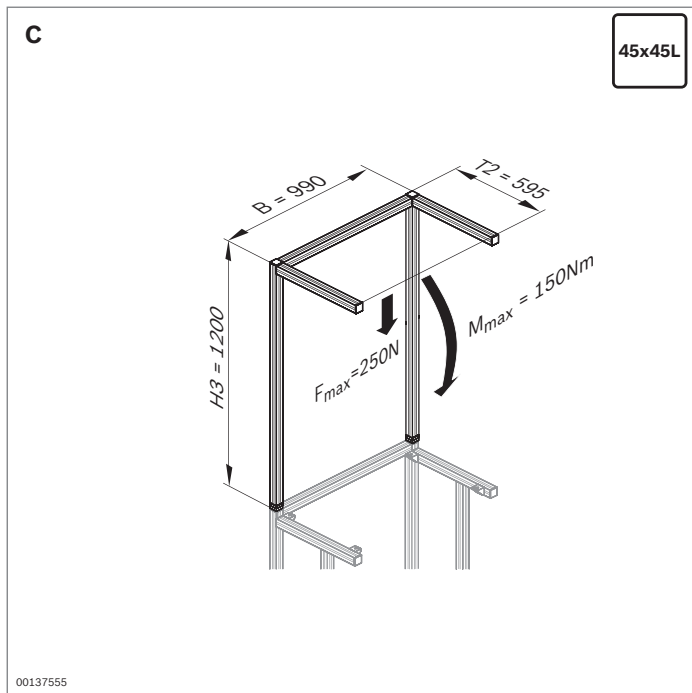
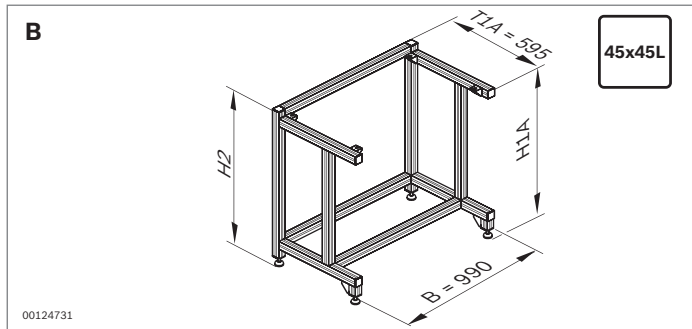
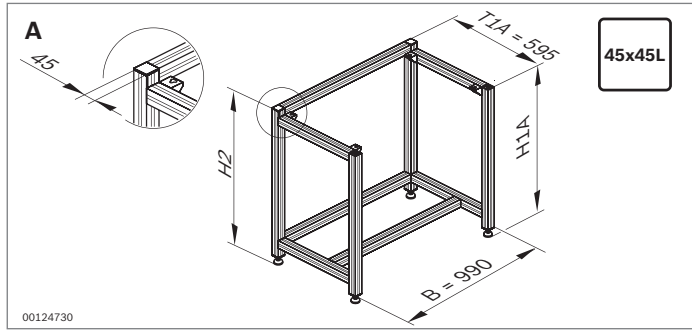
Workstation		3 842 998 110
<b>A</b>	Version	Disassembled, assembled
<b>ESD</b>	Conductivity	Yes, no
<b>PK</b>	Construction	Desk type, box type construction
<b>P</b>	Profile type	40L, 45L, 60L
<b>FU</b>	Foot type	Leveling foot, castor wheel
<b>BA</b>	Workstation width	410 ... 2000 mm
<b>H1A</b>	Work surface height	410 ... 1500 mm
<b>H2</b>	Total workstation height	410 ... 2500 mm
<b>T1A</b>	Workstation depth	405 ... 1000 mm
<b>T2</b>	Bracket depth	Up to 800 mm
<b>TP</b>	Table top type	4 different table tops
<b>SB<sub>typ</sub></b>	Side panel type	3 different side panels
<b>T3</b>	Accessory upright depth	Up to 800 mm
<b>NM</b>	No. material shelves	0 ... 4
<b>M</b>	Material shelf material	3 different material shelves
<b>TE</b>	Material shelf depth	410 ... 1220 mm
<b>SV</b>	Reinforced strut extension	With, without
<b>E</b>	Suspension profile	With, without
<b>A<sub>typ</sub></b>	Type of hanger	With, without hanger Selectable spring pulls
<b>L</b>	Country version	D, F, GB, CH, USA/CAN, CZ
<b>RCD</b>	Residual-current device	Yes/no
<b>SL<sub>typ</sub></b>	Type of lamp	4 different lamps
<b>S<sub>typ</sub></b>	Type of socket	4 different sockets
<b>DL</b>	Compressed air strip	With, without
<b>I<sub>typ</sub></b>	Type of information board	7 different information boards
<b>F<sub>typ</sub></b>	Type of footrest	Footrest selectable
<b>HLF</b>	Cloth and bottle holder	With, without



**MTpro**

Software for designing and planning workstations. For detailed information, see pages 1-9/10 or [www.boschrexroth.com](http://www.boschrexroth.com)

39554



### Table frame (A, B)



- ▶ Table frame of standard dimensions for box or desk type workstation construction
- ▶ Height-adjustable leveling feet to compensate for floor irregularities
- ▶ Suitable for the construction of ESD workstations
- ▶ Many extension options with accessories such as table tops and footrests
- ▶ Desk type construction for more legroom, especially when swiveling into/out of workstation while seated

### Strut extension (C)

- ▶ Strut extension of standard size for attaching accessories to workstations
- ▶ Subsequent installation on a table frame is possible
- ▶ Fits all Rexroth table frames with 45x45L profile and 990 mm width
- ▶ Fastened by means of end connector on table frame
- ▶ Suitable for the construction of ESD workstations

	H1A (mm)	H2 (mm)	No.
<b>A</b> Table frame, box type construction	860	900	<b>3 842 537 251</b>
	960	1000	<b>3 842 537 252</b>
<b>B</b> Table frame, desk type construction	860	900	<b>3 842 537 249</b>
	960	1000	<b>3 842 537 250</b>
<b>C</b> Strut extension			<b>3 842 519 530</b>

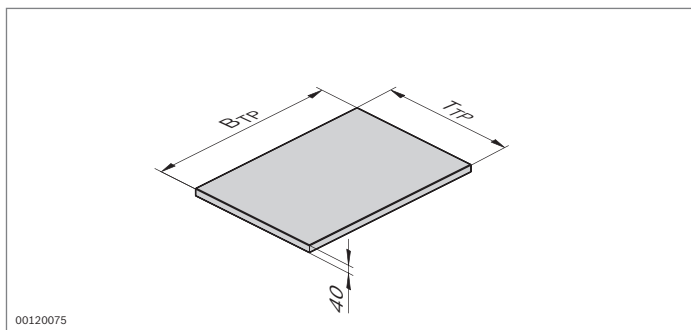


Table top		3842998250
Type	Version	Economic, Economic ESD Basic, Basic ESD
B <sub>TP</sub>	Table top width	400 ... 2700 mm
T <sub>TP</sub>	Table top depth	300 ... 2000 mm

Material: Economic table top: Coated chipboard, 0.1 mm layer thickness; edging: AB;

Basic table top: Coated chipboard, 0.8 mm layer thickness; edging: AB;

ESD versions volume conductive and surface conductive on both sides

Scope of delivery: Incl fastening material

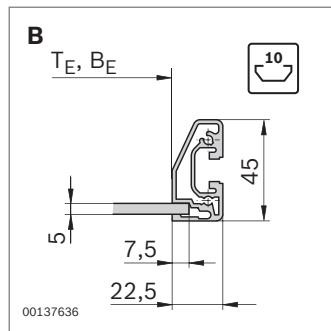
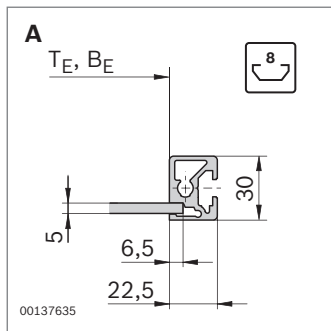
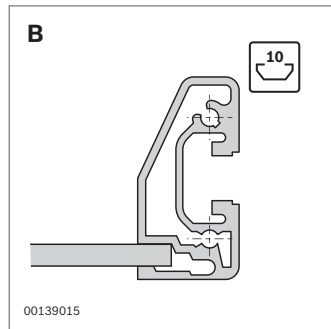
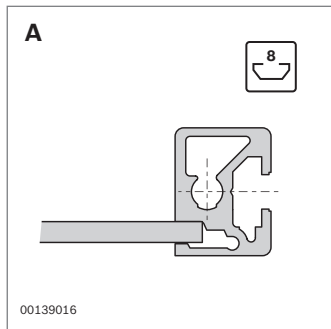
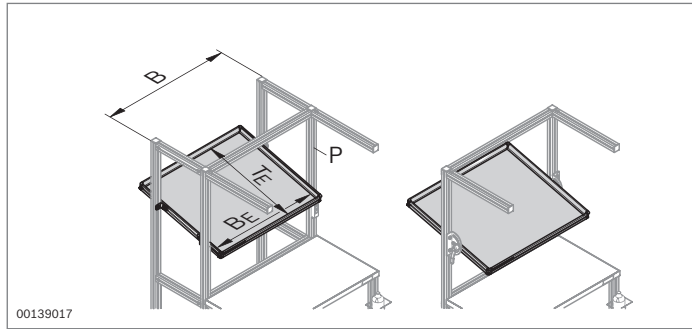
## Table top



- ▶ Table top for use in constructing Economic and Basic type Rexroth workstations for various mechanical loads
- ▶ Can be configured with variable dimensions or with fixed standard dimensions
- ▶ The Economic table top is suited for normal levels of mechanical stress on the table top surface
- ▶ The Basic table top with hard laminate coating is suited for high levels of mechanical stress on the table top surface
  - high abrasion resistance
  - high impact resistance and scratch resistance
  - resistant to organic solvents, weak acidic and caustic materials, gasoline and oil
  - briefly resistant to temperatures up to 180°C
- ▶ Available in ESD-conductive version: Safe conduction (without extra wiring) of charges through volume conductive base material conduction resistance (R) = 10<sup>4</sup> ... 10<sup>9</sup> Ω

2

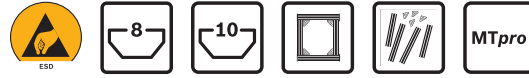
	B <sub>TP</sub> (mm)	T <sub>TP</sub> (mm)	ESD	No.
Table top Economic	1000	555		3 842 535 470
	1200	555		3 842 535 471
	1400	555		3 842 535 472
	1000	705		3 842 535 473
	1200	705		3 842 535 474
	1400	705		3 842 535 475
Table top Economic ESD	1000	555	⚡	3 842 535 476
	1200	555	⚡	3 842 535 477
	1400	555	⚡	3 842 535 478
	1000	705	⚡	3 842 535 479
	1200	705	⚡	3 842 535 480
	1400	705	⚡	3 842 535 481
Table top Basic	1000	555		3 842 535 489
	1200	555		3 842 535 490
	1400	555		3 842 535 491
Table top Basic ESD	1000	555	⚡	3 842 535 482
	1200	555	⚡	3 842 535 483
	1400	555	⚡	3 842 535 484



$B_E =$	$B - 45 - 80$	(P= 40L)
$B_E =$	$B - 45 - 90$	(P= 45L)
$B_E =$	$B - 45 - 120$	(P= 60L)

**See technical data  
page 13-5**

## Material shelves



- ▶ Material shelves for ergonomic accessibility of containers (Kanban), materials, measuring instruments and other aids at Rexroth workstations
- ▶ For implementing the 2-bin system
- ▶ Can be attached at any desired incline, height or offset
- ▶ Material shelf Economic (**A**) with frame profile 22.5x30
- ▶ Material shelf Basic (**B**) with frame profile 22.5x45 with docking aids for easy loading and removal of materials
- ▶ Plates
  - PP: Light gray
  - SB: ESD-conductive; black;  
recommended accessories: ESD mat insert
  - AL: Aluminum for heavy loads (material shelf Basic)
- ▶ Attachment fixed with brackets (scope of delivery) or swiveling with swivel mounting
- ▶ Customized assembly possible from individual components (see "Components" chapter)

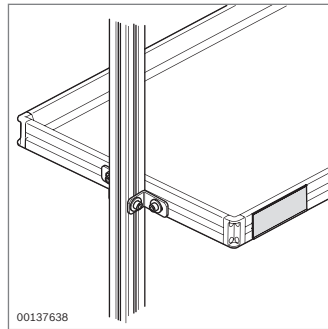
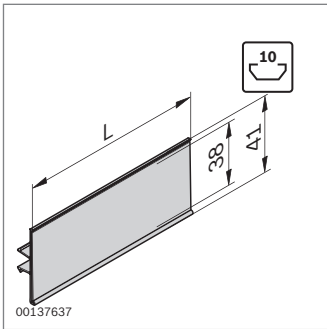
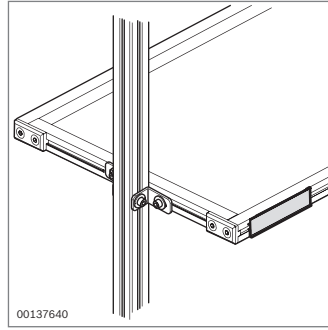
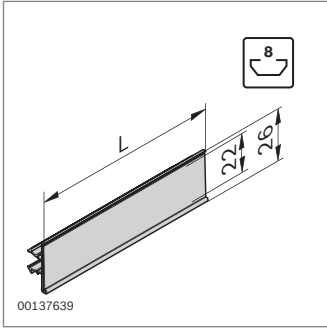
Scope of delivery: Includes brackets for fastening on 10 mm slot

Condition on delivery: Material shelf with standard dimensions: Fully assembled; material shelf

parameterizable: Disassembled, completely assembled

Accessories: Swivel mounting (page 12-4), ESD mat insert (page 2-54)


	Plate	$B_E$ (mm)	$T_E$ (mm)	ESD	No.
<b>A</b> Material shelf Economic	PP	610	410		<b>3 842 538 456</b>
		855	410		<b>3 842 538 457</b>
	SB	610	410	⚠	<b>3 842 538 458</b>
		855	410	⚠	<b>3 842 538 459</b>
<b>B</b> Material shelf Basic	PP	610	410		<b>3 842 538 460</b>
		200 ... 1000	310 ... 1000		<b>3 842 998 183</b>
	SB	610	410	⚠	<b>3 842 538 461</b>
		200 ... 1000	310 ... 1000	⚠	<b>3 842 998 184</b>
	AL	200 ... 1480	310 ... 1220		<b>3 842 998 155</b>

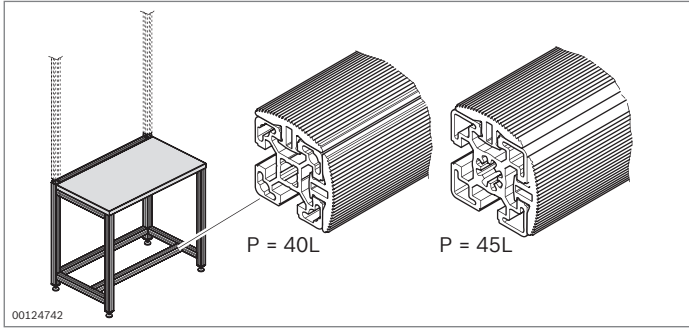


**Labeling clips**

- ▶ For labeling material shelves
- ▶ Suitable for labeling all profiles with 8 mm or 10 mm slot
- ▶ For clipping into the slot

Color: Light gray (7035); transparent

	Length (mm)		No.
Labeling clips N8	2000	20	<b>3 842 537 113</b>
	102	20	<b>3 842 537 650</b>
Labeling clips N10	2000	20	<b>3 842 537 116</b>
	102	20	<b>3 842 537 651</b>



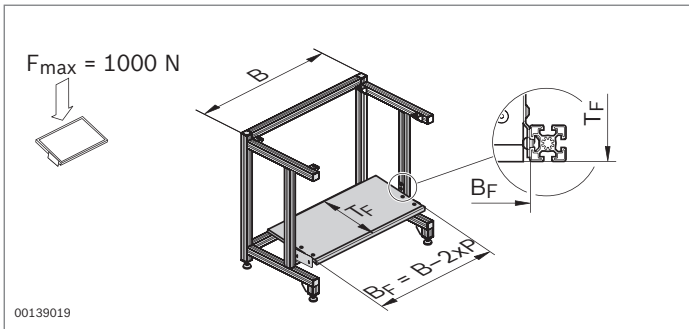
	L (mm)		ESD	No.
Rubber profile	30000	1		<b>3 842 562 090</b>
	30 ... 30000			<b>3 842 994 979/L</b>

### Rubber profile



- ▶ To avoid impact on hard edges, such as when setting down impact-sensitive products
- ▶ As a footrest: Clip in from top and front on the cross strut of the workstation
- ▶ Really simple and inexpensive
- ▶ Suitable for the construction of ESD workstations

Material: EPDM; conduction resistance (R) < 1 x 10<sup>9</sup> Ω



<b>Footrest Economic</b>		<b>3 842 998 256</b>
<b>ESD</b> Conductivity		Yes/no
<b>B<sub>F</sub></b> Footrest width	400 ... 1020 mm	
<b>T<sub>F</sub></b> Footrest depth	300 ... 600 mm	

<b>Footrest Economic</b>	<b>B<sub>F</sub> (mm)</b>	<b>T<sub>F</sub> (mm)</b>	<b>ESD</b>	<b>No.</b>
assembled	900	400		<b>3 842 538 771</b>
	900	400		<b>3 842 538 772</b>

### Footrest Economic

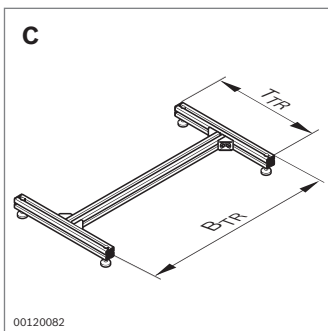
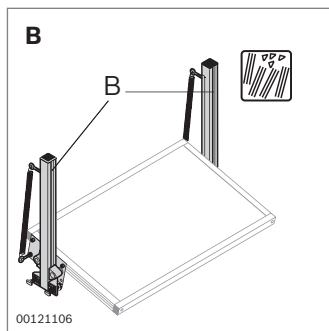
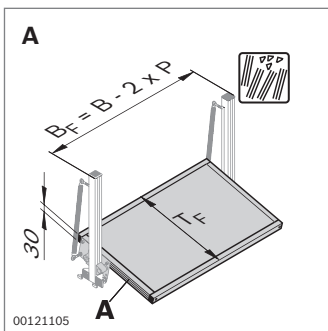
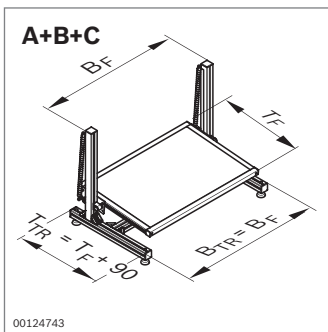


- ▶ For 0 – 7° inclination
- ▶ For low-fatigue sitting at the workstation
- ▶ Attachment to the table frame for box or desk type construction
- ▶ Oil-resistant
- ▶ Aluminum U-profile on front edge to prevent premature wear of the footrest edge
- ▶ Suitable for the construction of ESD workstations

Material: Chipboard, hard-coated;  
conduction resistance (R) < 1 x 10<sup>9</sup> Ω

Scope of delivery: Includes fastening material (10 mm slot);  
ESD version incl. fastening material and grounding cable  
(10 mm slot) (page 2-54)

**See technical data**  
**page 13-6**



See technical data  
page 13-6

## Footrest Basic Support frame



- ▶ With fixed inclination of 5°
- ▶ For low-fatigue sitting at the workstation
- ▶ Easy height adjustment while seated (adjustment range: 250 mm)
- ▶ Installed on table frame using attachment kit
- ▶ Installed on free-standing support frame using attachment kit
- ▶ Oil-resistant
- ▶ Suitable for the construction of ESD workstations

Material: Frame: Aluminum profile; anodized

Rest material: Chipboard, hard-coated;

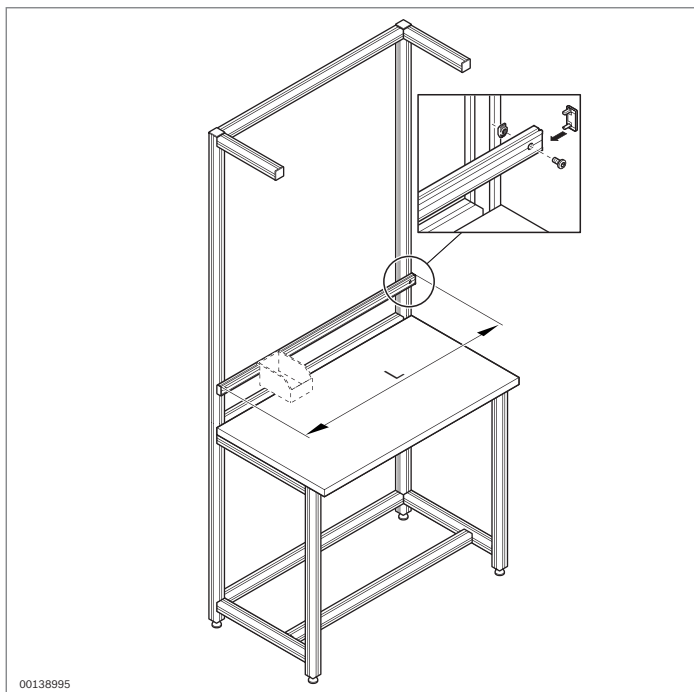
conduction resistance (R) < 1 x 10<sup>9</sup> Ω

Scope of delivery: Incl fastening material (10 mm slot);

ESD version incl. fastening material and grounding cable (10 mm slot) (page 2-54)

Footrest Basic		3 842 998 257
A, B, C	A Version	Disassembled, assembled
	ESD Conductivity	Yes, no
B <sub>F</sub>	Footrest width	400 ... 1020 mm
T <sub>F</sub>	Footrest depth	350 ... 600 mm
T <sub>R</sub>	Support frame	Yes, no

	B <sub>F</sub> (mm)	T <sub>F</sub> (mm)	B <sub>TR</sub> (mm)	T <sub>TR</sub> (mm)	ESD	No.
A Footrest Basic	900	530				3 842 515 160
	900	530			⚡	3 842 538 098
B Attachment kit						3 842 537 737
A+B Footrest Basic + attachment kit	900	530				3 842 519 735
	900	530			⚡	3 842 538 409
C Support frame			900	558		3 842 521 013

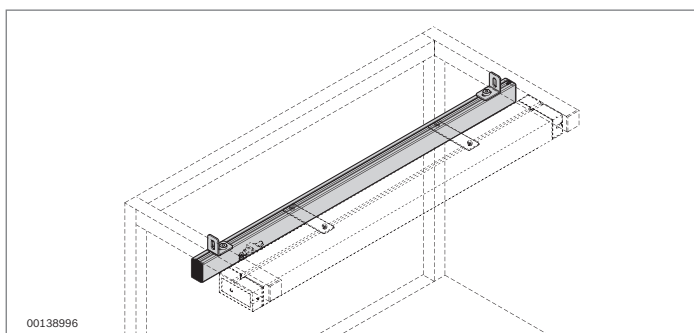
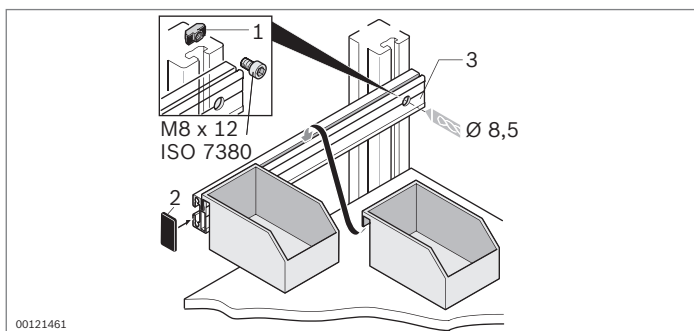


## Applications

### Suspension profile application

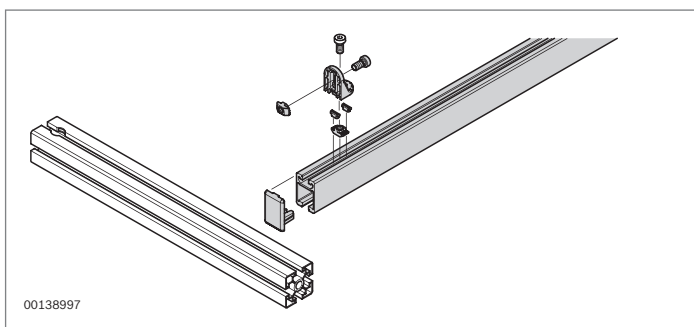
- ▶ To provide ready access to plastic grab containers and trays at the workstation or in the material shuttle
- ▶ Customized assembly from individual components (cf. "Components" chapter, page 12-11 f.)

See technical data  
page 13-7



### Hanger application

- ▶ For the ergonomic supply of tools in combination with trolley or slide hanger and spring pull
- ▶ For hanging system lamps at the workstation
- ▶ Customized assembly from individual components (cf. "Components" chapter, page 12-10)



See technical data  
page 13-8



00120990

## Spring pull

### Spring pull (A, B)

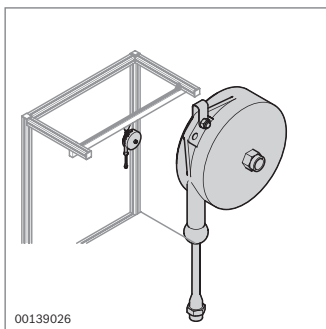
- ▶ Ergonomic positioning of tools, e.g. screwdrivers, to reduce uneven and high strain on workers
- ▶ The bearing load and cable length are adjustable
- ▶ Assembly at workstation with hanger and trolley or slide hanger

Scope of delivery: Includes safety wire

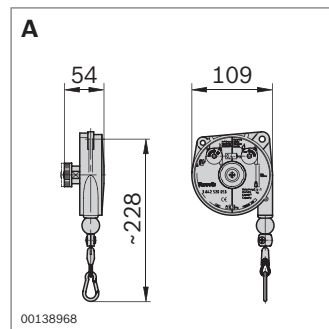
### Spring pull with retractable cable (C)

- ▶ Ergonomic positioning of air-powered tools, e.g. pneumatic screwdrivers, to reduce uneven and high strain on workers
- ▶ Compressed air supplied via air bar
- ▶ Compressed air connection for feed line and tool connection: G1/4"
- ▶ The bearing load and cable length are adjustable
- ▶ Assembly at workstation with hanger and trolley or slide hanger

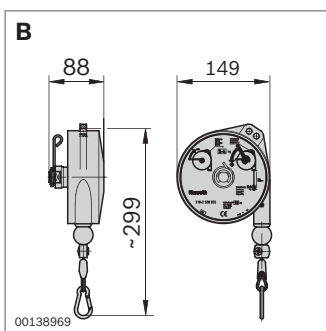
Scope of delivery: Includes safety wire, connection tubing G1/4"



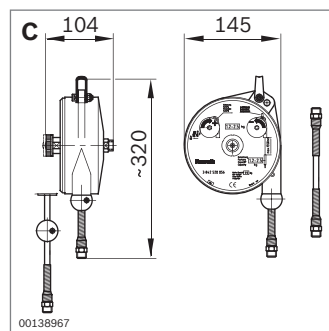
00139026



00138968

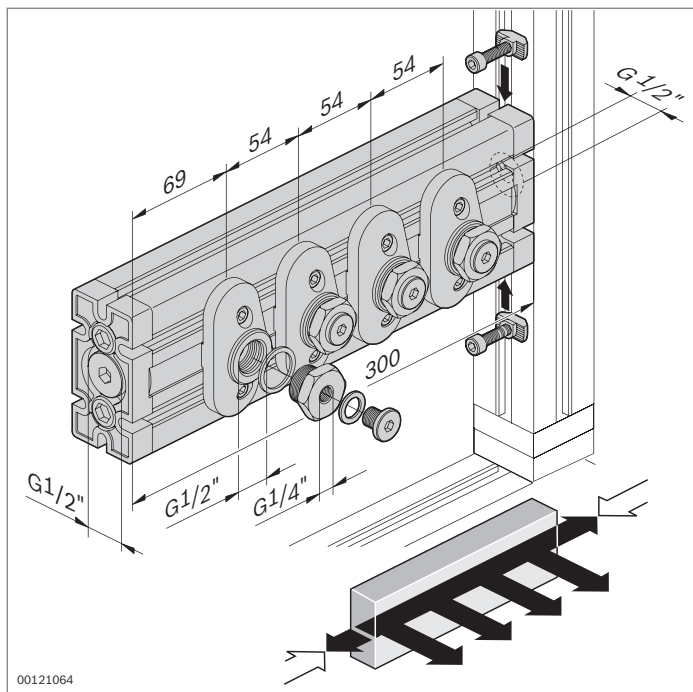


00138969



00138967

Spring pull	Bearing load (kg)	System weight (kg)	Retractable cable (mm)	No.
<b>A</b> Spring pull	0.4 ... 1.0	0.6	1600	<b>3 842 520 053</b>
	1.0 ... 2.0	0.6	1600	<b>3 842 520 054</b>
<b>B</b> Spring pull	2.0 ... 4.0	2.0	2000	<b>3 842 520 055</b>
<b>C</b> Spring pull with retractable cable	1.2 ... 2.5	1.4	1350	<b>3 842 520 056</b>



00121064

### Air bar

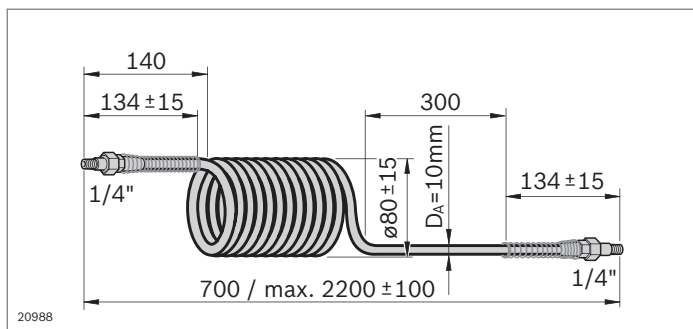


- ▶ Distributor and connection point at workstation for compressed air for up to 4 tools
- ▶ Max. 8 bar
- ▶ Compressed air connection for feed line: G1/2"
- ▶ Compressed air connection for discharge: G1/2" or G1/4" (reducing adapters)

Material: Seals: NBR

Scope of delivery: Incl fastening material for 10 mm slot

No.	
Air bar	3 842 352 088



20988

### Spiral hose

- ▶ For connecting tools to the air bar
- ▶ Hose connection with kink protection, rotatable with sealing ring; 1/4" external thread
- ▶ Max. extension length 2200 mm
- ▶ Operating pressure: Pmax = 8 bar at 20°C
- ▶ Requires de-oiled air

Material: PU hose, blue; steel connection

No.	
Spiral hose	3 842 544 790



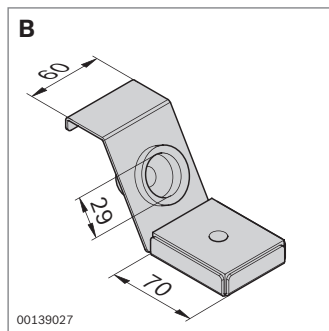
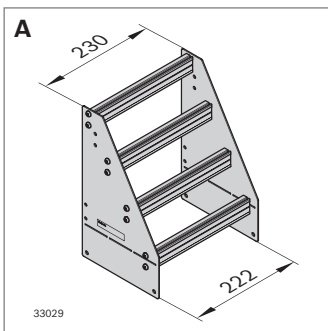
**Tool shelf  
Tool holder**



- ▶ Tool shelf available with a fixed width of 230 mm
- ▶ For ergonomic and handy positioning of tools at the workstation
- ▶ Tool holders are hung in the tool shelf.
- ▶ Customized assembly of individual components:  
See "Components" chapter (page 12-1 f.)

Material B: VA

	ESD	No.
<b>A</b> Tool shelf	⚠	<b>3 842 554 909</b>
<b>B</b> Tool holder for soldering irons	⚠	<b>3 842 514 524</b>





## Tool holders Container mount

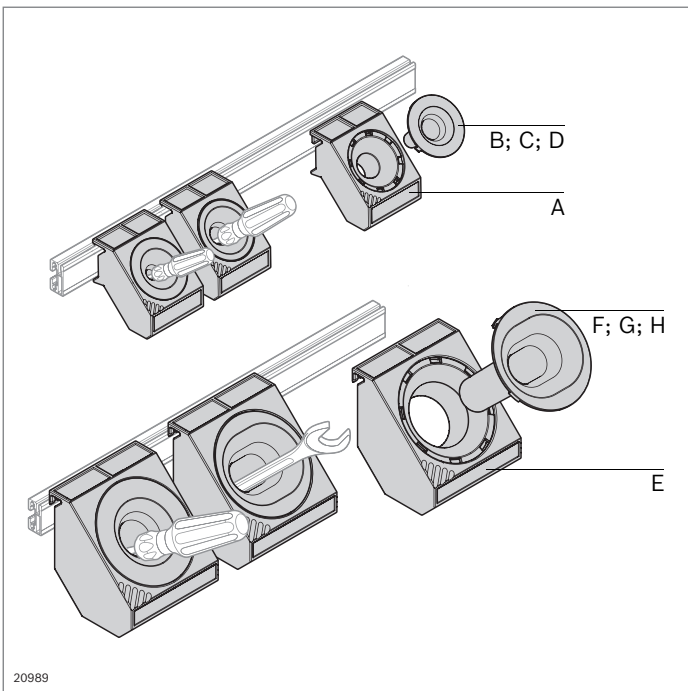


### Tool holders

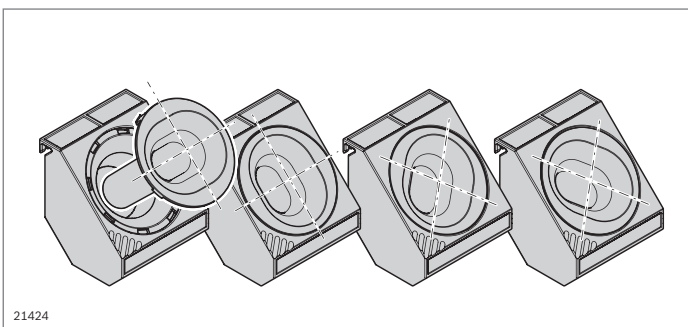
- ▶ For ergonomic and handy positioning of tools at the workstation
- ▶ Time savings of 10 % to 20 % based on MTM, achievable with
  - defined place for fast retrieval
  - 45° docking aids in bucket-tray for easy, ergonomic depositing and removal of tools
  - 45° tilt of tool holder for easy picking
- ▶ Round and oval bucket-trays, open or closed base, for insertion in matching tool holders
- ▶ Four different positions possible for oval bucket-trays in tool holders for ergonomic picking and placing
- ▶ Tool holder to hang in a suspension profile or container mount
- ▶ Tool holder with space for adhesive label

Material: PA 6, black; conduction resistance (R) <math>1 \times 10^9 \Omega</math>

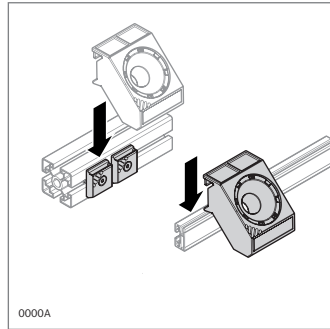
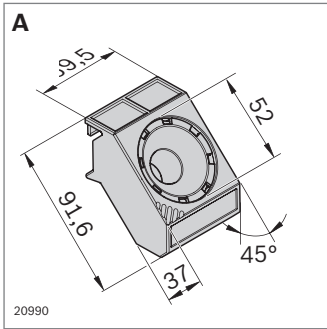
- ▶ Self-assembly elements for custom configurations of tool holder shelves: See "Components" chapter (page 12-1 f.)



20989

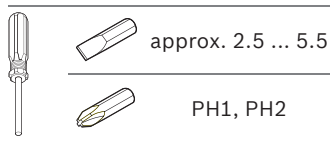
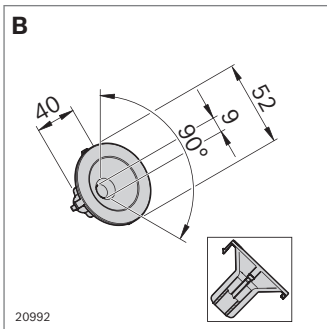


21424

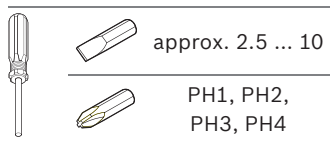
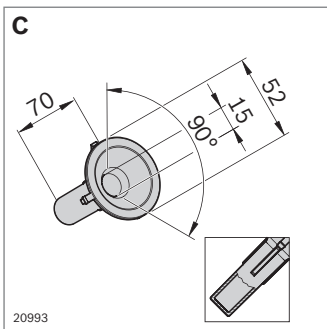


**D52 tool holders for D52-9 and D52-15 bucket trays**

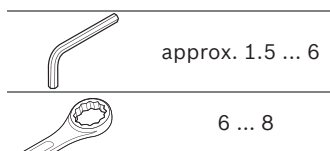
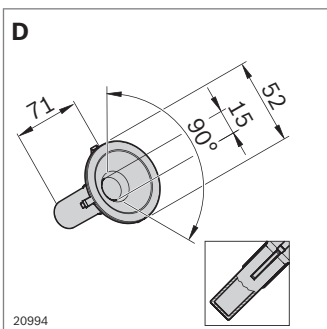
	ESD	No.
A D52 tool holder	⚠	3 842 544 832



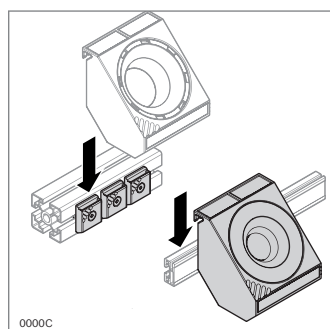
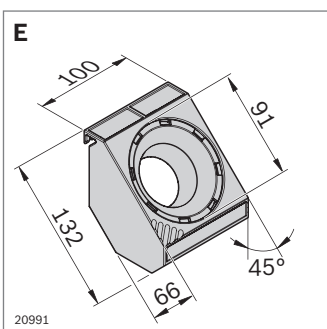
	ESD	No.
B D52-9 bucket tray (without base)	⚠	3 842 544 834



	ESD	No.
C D52-15 bucket tray (without base)	⚠	3 842 514 835



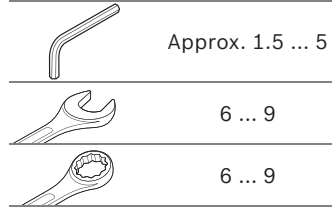
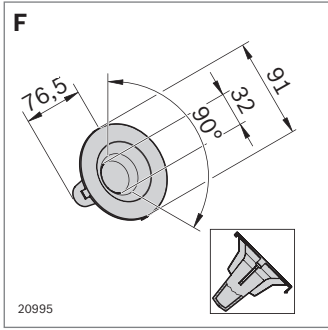
	ESD	No.
D D52-15 bucket tray (with base)	⚠	3 842 514 836



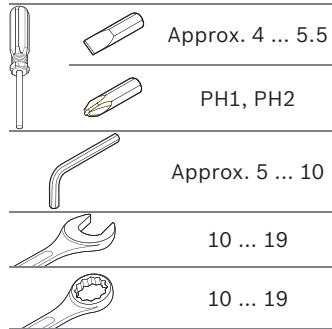
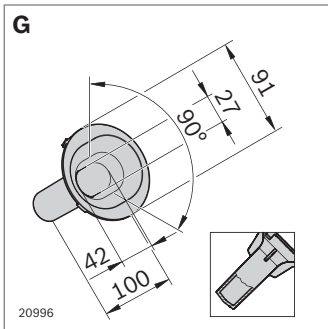
**D91 Tool holder for bucket trays D91-32, D91 Oval53 L100 and D91 Oval53 L136**

	ESD	No.
E D91 tool holder	⚠	3 842 544 833

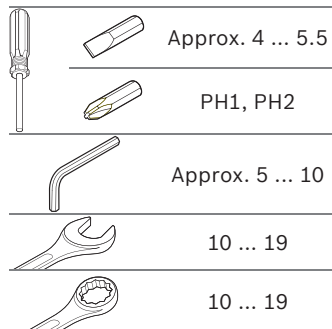
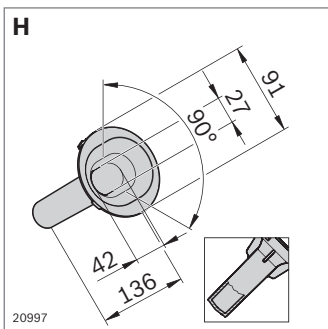
2



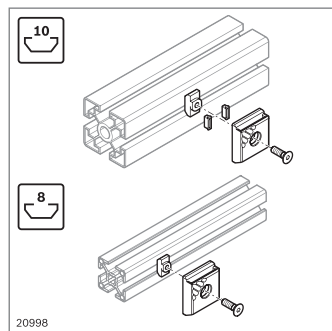
	ESD	No.
<b>F</b> D91-32 bucket tray (with base)		<b>3 842 544 837</b>



	ESD	No.
<b>G</b> Bucket-tray D91 Oval53 L100 (with base)		<b>3 842 546 744</b>



	ESD	No.
<b>H</b> Bucket tray D91 Oval53 L136 (with base)		<b>3 842 546 745</b>



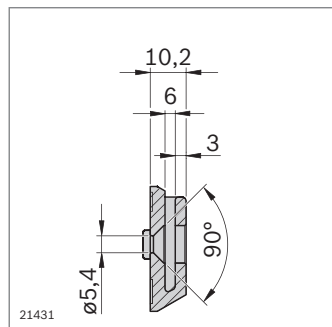
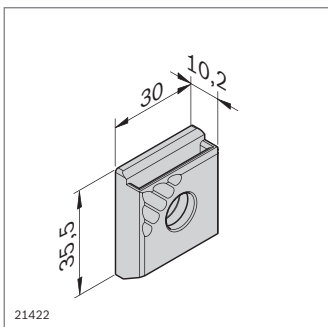
**Container mount**

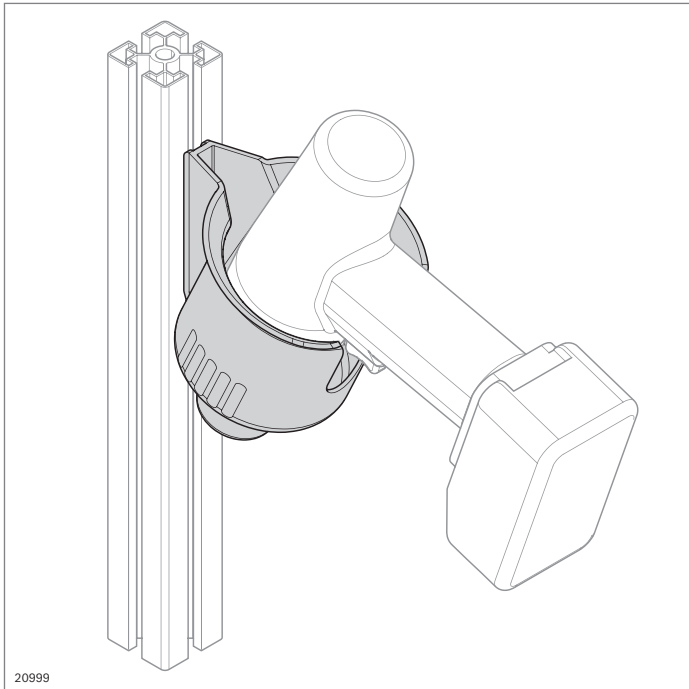
- ▶ Container mount for mounting tool holders, grab containers, grab trays and grab ledges
- ▶ Suitable for 8 mm and 10 mm slot

Material: PA 66; black

Scope of delivery: Includes fastening material for fastening in 8 mm and 10 mm slots

	ESD	No.
Container mount		<b>3 842 544 797</b>





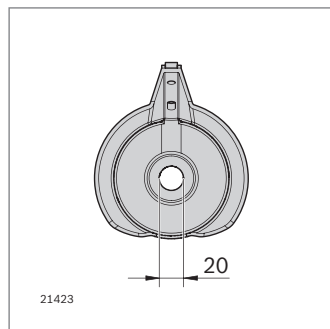
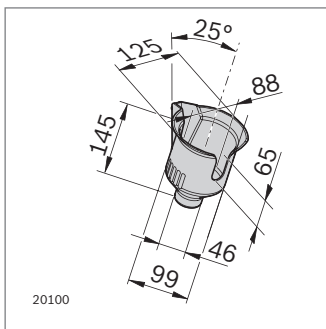
## D95 tool holder



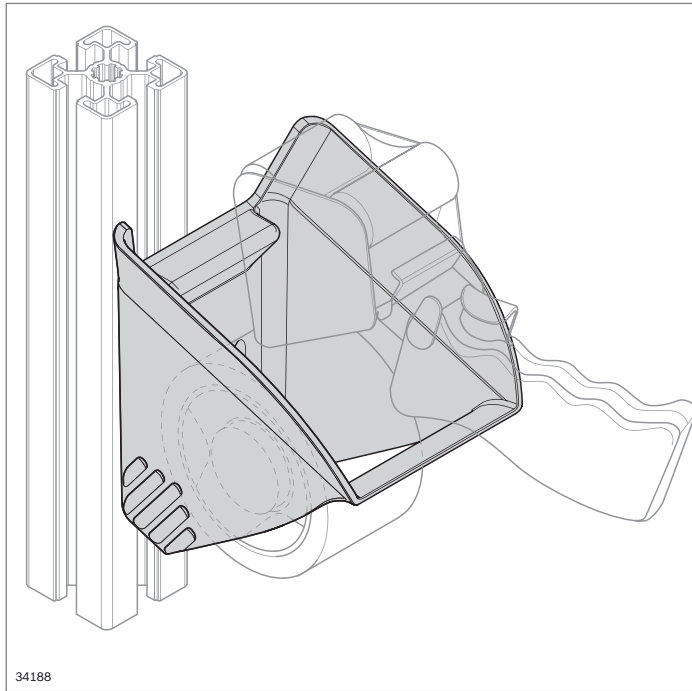
- ▶ Quiver-type tool holder for nut runners up to 2 kg (the use of a spring pull is recommended for heavier nut runners, page 2-22)
- ▶ Time savings of 10 % to 20 % based on MTM, achievable with
  - Defined place for fast picking
  - 45° docking aids for easy, ergonomic depositing and removal
- ▶ Tool holder open at bottom. This makes it possible to hold nut runners with long tool inserts. Dirt does not collect in the quiver
- ▶ Notched housing for clearly defined stowage
- ▶ Centering lugs for easy fastening in vertical 10 mm slot

Material: PA 6, black

Scope of delivery: Includes fastening material for fastening in 10 mm slots



	ESD	No.
D95 tool holder		3 842 544 772



### Tool holder TAPE 50 mm

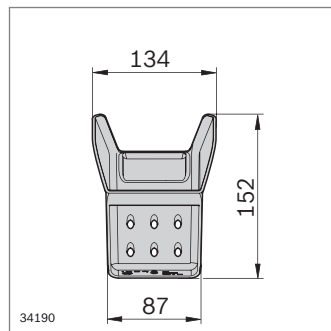
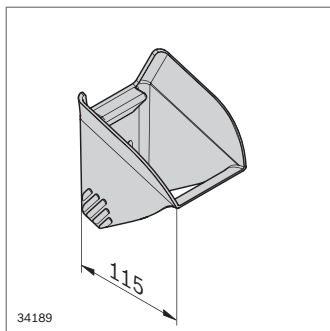


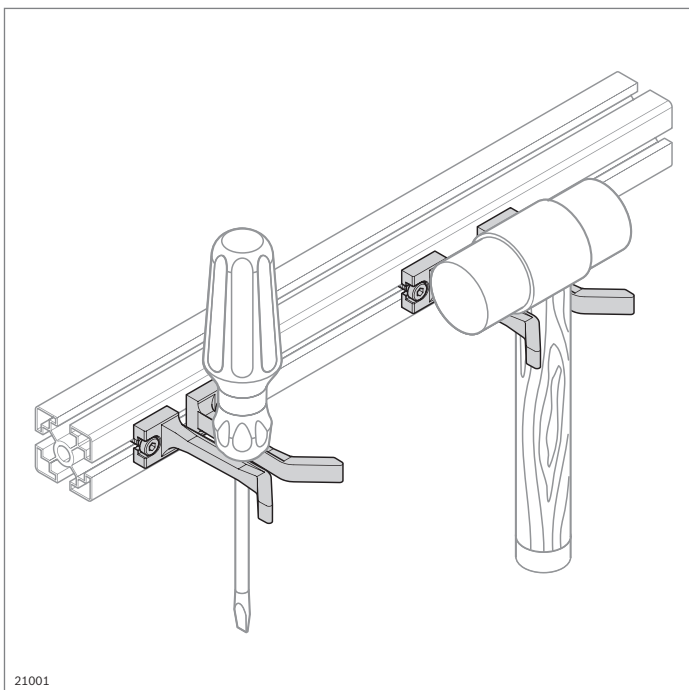
- ▶ Tool holder for tape dispenser with a width of 50 mm
- ▶ Time savings of 10 % to 20 % based on MTM, achievable with
  - defined place for faster reaching and picking
  - docking aids for easy, ergonomic depositing
- ▶ Supports 5S principles for order and cleanliness at the workstation via defined, fixed place

Material: PA 6; black

Scope of delivery: Includes fastening material for fastening in 8 mm or 10 mm slots

	ESD	No.
Tool holder TAPE 50 mm		<b>3 842 555 673</b>





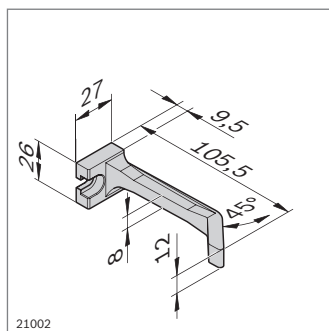
## L105 tool holder



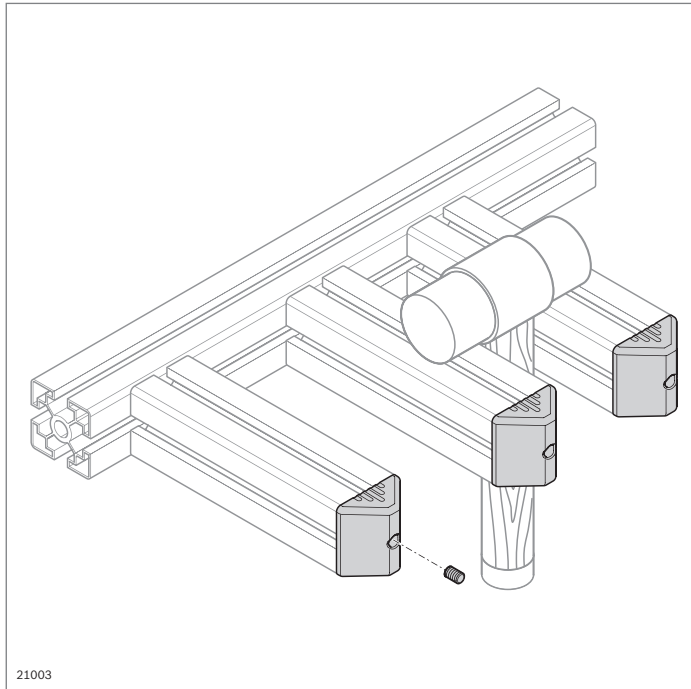
- ▶ For ergonomic and handy positioning of tools at the workstation
- ▶ Universal use possible, e.g., for screwdrivers, pliers, or hammers
- ▶ Mounting in 8 mm and 10 mm slots
- ▶ Time savings of 10 % to 20 % based on MTM, achievable with
  - defined place for fast retrieval
  - 45° docking aids and tactile feedback for easy depositing

Material: PA 6, black

Scope of delivery: Includes fastening material for fastening in 8 mm or 10 mm slots



	ESD	No.
L105 tool holder	10	3 842 544 768




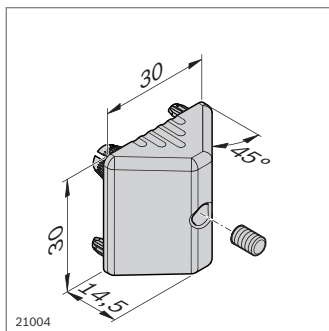
### Guide plate 30x30

- ▶ Guide plate 30x30 as cover cap for 30x30 profile
- ▶ For the construction of supply racks (minomi racks) for the simple suspension of tools and parts between 30x30 profiles
- ▶ Yellow coloring for faster recognition by workers
- ▶ Time savings of 10 % to 20 % based on MTM, achievable with
  - defined place for fast retrieval
  - 45° docking aids for easy depositing

Material: PA 6; yellow (RAL 1003)

Scope of delivery: Includes headless setscrew for added stability

		No.
Guide plate 30x30	10	<b>3 842 544 770</b>





## Workstation lighting

The right lighting, adapted to the activity at the workstation, is a basic prerequisite for high efficiency and processing quality. Optimal lighting prevents fatigue, improves concentration, and performance, and reduces the number of errors. From an ergonomic point of view, lighting is another central environmental factor that must be taken into consideration in addition to climate, noise, mechanical vibrations, and hazardous substances.

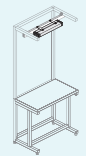
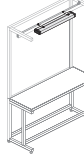
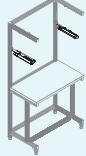

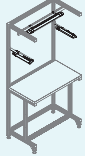
Important aspects for planning workstation lighting include:

- ▶ Avoiding strong contrasts
- ▶ Avoiding glare and reflection

DIN EN 12464 or the table below contain the required mid-range lighting strengths.

**SL LED basic in the tri-light setup – the components:**  
**1x SL 24 basic, 2x SL 12 basic,**  
**power supply DIM box,**  
**mains cable, 3x connection**  
**cable, 4x fastening kit Bracket**

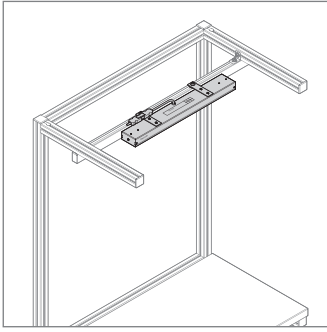
**See technical data**  
**page 13-10**

The right LED system lamp for every task						
Sample calculation for work top lighting						
Rexroth SL 12 economic (nominal lighting strength) 700 lux* + 300 lux ambient light = 1000 lux work top lighting						
Tasks	Required lighting strength (lux)	 SL 12 economic	 SL 12 economic wide	 SL 12 basic Duo	 SL 24 basic	 SL 24 basic + SL 12 basic Duo (tri-light)
Rough and medium machine and assembly tasks such as turning, milling and planing	300	■ *	■ *	■ *	■ *	■ *
Fine machine tasks with permissible deviations	500	■■ *	■■ *	■■ *	■■ *	■■ *
Fine assembly tasks, e.g., telephones, winding medium-sized coils, marking, inspection and measuring stations	750	■■■■ *	■■■■ *	■■■■ *	■■■■ *	■■■■ *
Very fine assembly, e.g., measuring instruments, assembly of tools, gages, and equipment, precision mechanics and micromechanics	1000	■■■■ *		■■■■ *	■■■■ *	■■■■ *
Assembly, inspection and adjustment of extremely small parts	1500					■■■■ *

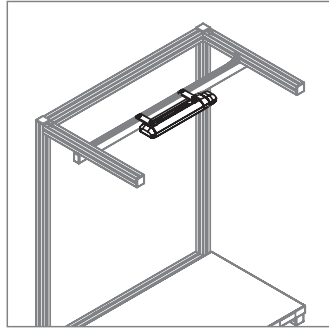
\* lamp-table top distance = 1.25 m

■ System lamp sufficient for task  
 ■■■■ System lamp + ambient light (300 lux) sufficient for task

**System lamp economic**



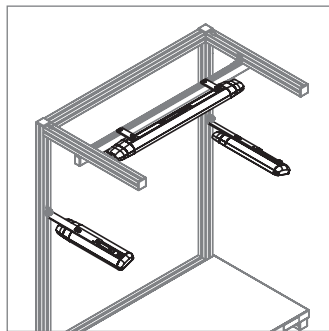
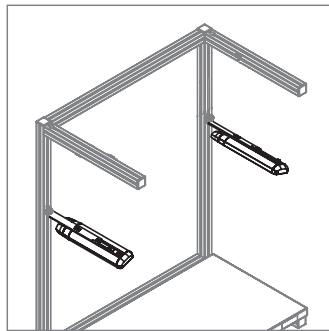
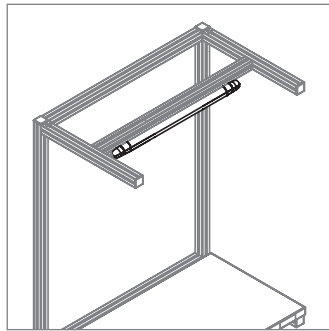
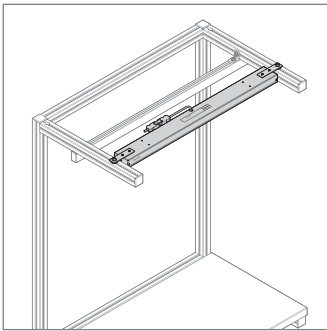
**System lamp basic**



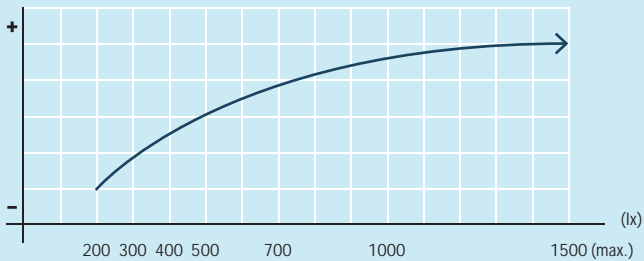
Rexroth's system lamp range provides glare and flicker-free light of the highest quality. For high-quality and even workstation lighting, the lamps can be operated individually or in combination with one another depending on the task. The lamps can be switched on and off when plugged into a socket with a power switch. Several lamps can be connected in series using the connection cables.

**LED lighting on a new level**

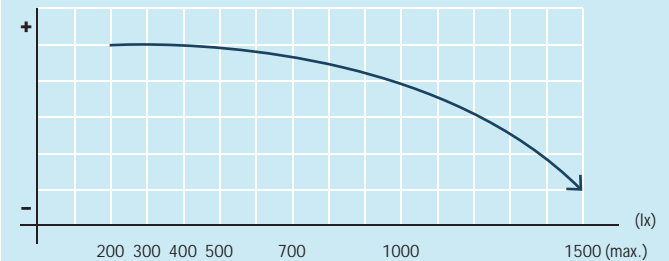
The design of the new generation of LED lamps sets itself apart by its compact size. The use of LEDs for lighting makes possible low energy consumption, long life and maintenance-free lamps. With the rotary control of the DIM box, the illuminance of the SL LED basic can be dimmed infinitely and the lamp can be switched on and off.



**Increased efficiency with Rexroth system lamps**



**Reduction of errors with Rexroth system lamps**





### System lamp LED economic

- ▶ Glare-free light thanks to matte wide optics with 60° beam angle
- ▶ Optimum light output with low energy consumption: ~140 lm/W
- ▶ Color temperature: 5000 K
- ▶ With short flexible connection cable (~16 cm) and GST plug
- ▶ Compact dimensions and low weight
- ▶ Particularly suitable for workstations intended for packing operations and heavy assembly work
- ▶ Mounting on profile rail or bottom side of profile rail (workstations with W ≠ 1000 mm) as well as SL12 wide to a strut extension (workstations with W = 1000 mm) (page 2-21)

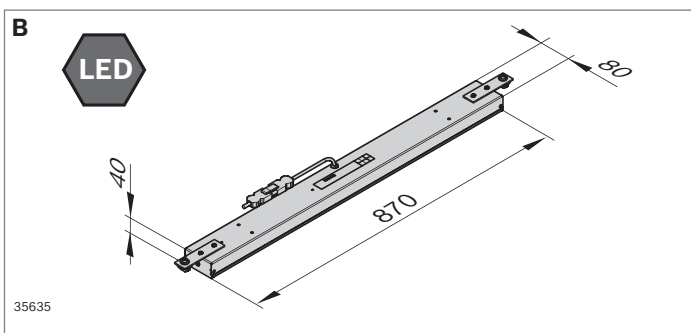
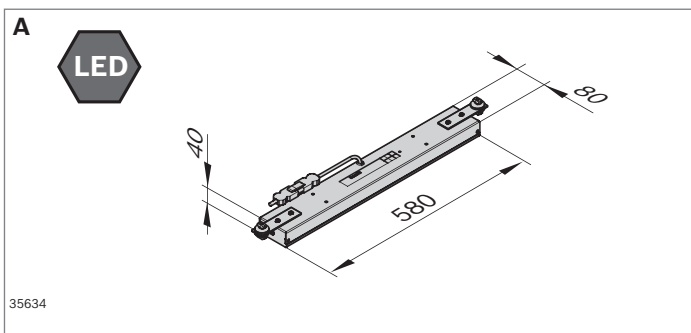
IP rating: IP 20 (DIN EN IEC 60529)

Material: Housing sheet steel, painted

Scope of delivery: Incl fastening material (10 mm slot)

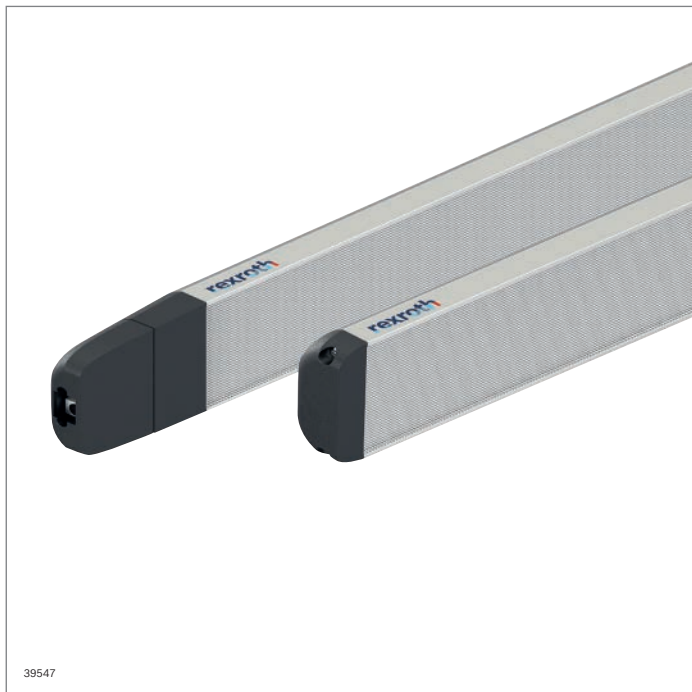
Required accessories: Mains cable or connection cable (page 2-39)

Recommended accessories: POWER H-distributor (230 V) or T-plug (page 2-41)



		Fluorescent tubes	Service life (h)	Voltage (V)/ Frequency (Hz)	Weight (kg)	No.
<b>A</b> SL 12 LED economic	EU	LED/11.5 ± 0.5 W	50 000	220-240 V/50 Hz; 60 Hz	1.75	<b>3 842 559 392</b>
	USA/CAN*	LED/11.5 ± 0.5 W	50 000	120-277 V/50 Hz; 60 Hz	1.75	<b>3 842 559 394</b>
<b>B</b> System SL 12 LED economic wide	EU	LED/11.5 ± 0.5 W	50 000	220-240 V/50 Hz; 60 Hz	2.65	<b>3 842 559 393</b>
	USA/CAN*	LED/11.5 ± 0.5 W	50 000	120-277 V/50 Hz; 60 Hz	2.65	<b>3 842 559 395</b>

\*UL and CSA test marks



### System lamp LED basic



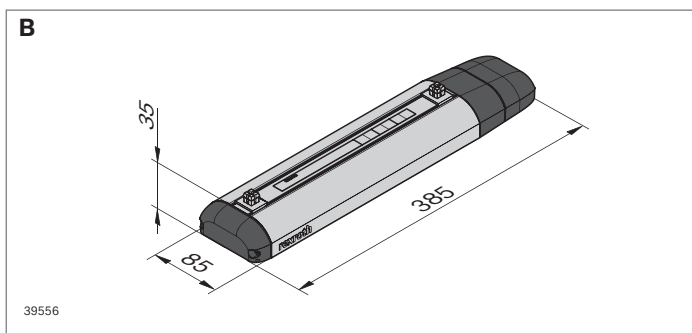
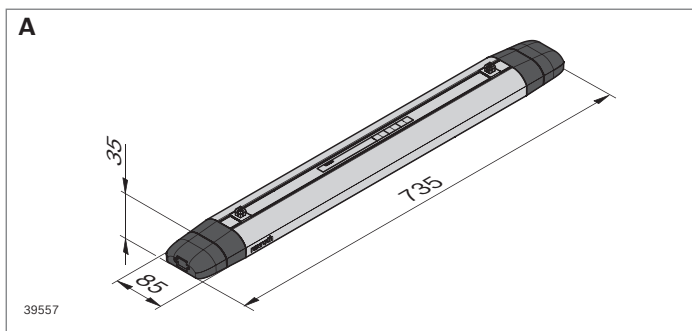
- ▶ SL 24 basic: Easy and fast fastening in slot with mounting base; through-wired with two outputs for connecting further lamps
- ▶ SL 12 basic: Easy and fast fastening in slot with mounting base; with one output for connecting another lamp
- ▶ Suitable for use at ESD workstations when using fastening kit Plate (D) or Bracket (E)
- ▶ Color temperature: 5000 K

IP rating: IP 20 (IEC 60529)

Material: Aluminum housing; anodized; mounting base, 10 mm slot (3842552247)

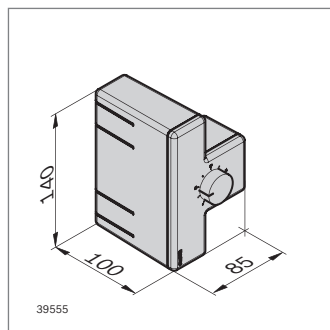
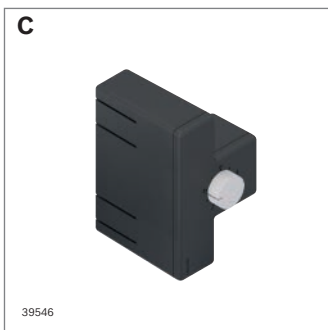
Scope of delivery: Incl fastening material (10 mm slot)

Required accessories: Power supply DIM box (C), mains cable, connection cable (F)



		<b>Fluorescent tubes</b>	<b>Service life</b> (h)	<b>Voltage (V)/ Frequency (Hz)</b>	<b>Weight</b> (kg)	<b>No.</b>
<b>A</b>	SL 24 LED basic	EU/USA/CAN* LED/24 W	60 000	<60 V (DC SELV)	1.0	<b>3 842 563 245</b>
<b>B</b>	SL 12 LED basic	EU/USA/CAN* LED/12 W	60 000	<60 V (DC SELV)	0.6	<b>3 842 563 246</b>

\*UL and CSA test marks

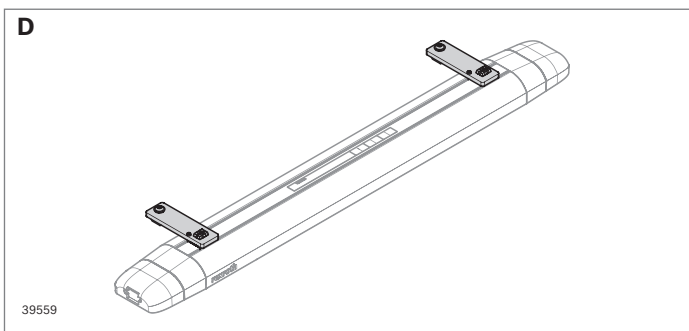


### Power supply DIM box

- ▶ For power supply of up to two SL 24 basic or four SL 12 basic system lamps (combinations of SL 12 basic and SL 24 basic possible)
- ▶ Stepless dimming (0 – 100%) via ergonomic rotary control
- ▶ Mains connection via GST (with mains cable, connection cable, connecting plug (page 2-41))
- ▶ DC lamp connection via GST mini (GST mini connection cable)
- ▶ Simple and versatile fastening options in slot thanks to mounting base (included)
- ▶ Can be connected directly to the socket strip via the GST connecting plug (3842517055)

		Service life (h)	Voltage (V)/Frequency (Hz)	Weight (kg)	No.	
<b>C</b>	Power supply DIM box	EU/USA/CAN*	45 000	110-240 V; 50 – 60 Hz	0.4	<b>3 842 563 247</b>

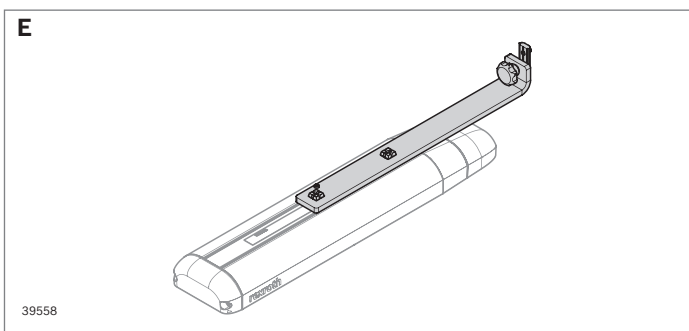
\* UL and CSA test marks from CW 25/22



### Fastening kit Plate

- ▶ For installation on hanger (page 2-21)

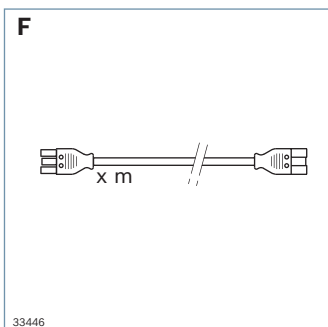
	No.	
<b>D</b>	Fastening kit Plate	<b>3 842 563 254</b>



### Fastening kit Bracket

- ▶ For installation on a strut extension; swivel-mounted

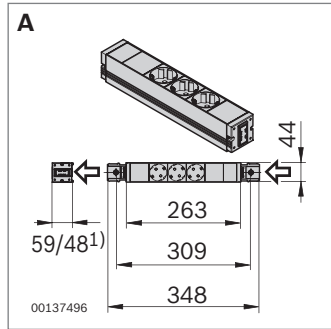
	No.	
<b>E</b>	Fastening kit Bracket	<b>3 842 563 276</b>



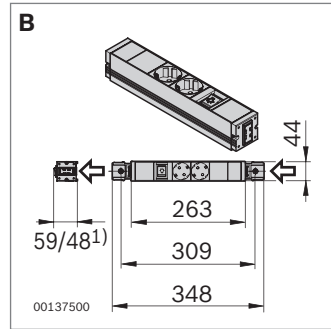
### Connection cable

- ▶ For connection of power supply DIM box with system lamp basic
- ▶ For connection of system lamp basic with additional system lamp basic

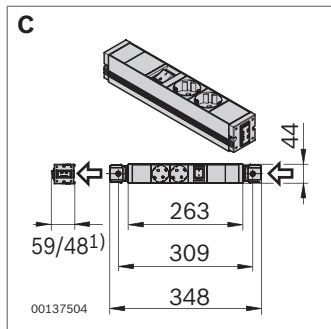
		Length (m)	No.
<b>F</b>	Connection cable EU/USA/CAN GST mini	1	<b>3 842 563 248</b>
		2	<b>3 842 563 249</b>
		3	<b>3 842 563 250</b>



<sup>1)</sup> Special country-specific dimensions

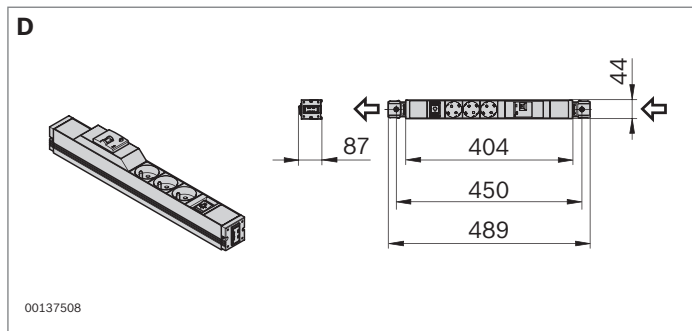


<sup>1)</sup> Special country-specific dimensions



<sup>1)</sup> Special country-specific dimensions

**IP rating:**  
**IP 20 (DIN EN IEC 60529)**



00137508

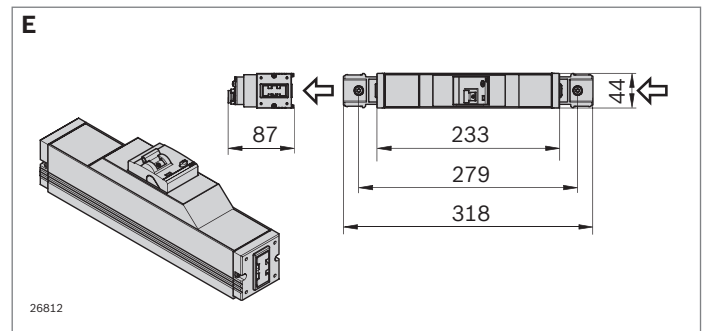
## Socket strip

- ▶ With two, three or four grounded plug sockets
- ▶ Socket insert for space-saving layout with angled plugs
- ▶ With GST outlet socket including cover cap for looping through the electrical current
- ▶ When connecting several products in series, observe the maximum permissible current. See the table below
- ▶ Intended for permanent installation
- ▶ Versions with switchable input and/or output and RCD safety switch
- ▶ RCD module:  $I_{\Delta n} = 30 \text{ mA}$

Material: Aluminum, anodized; insert: Plastic, black

Scope of delivery: Includes insulating fastening material (10 mm slot)

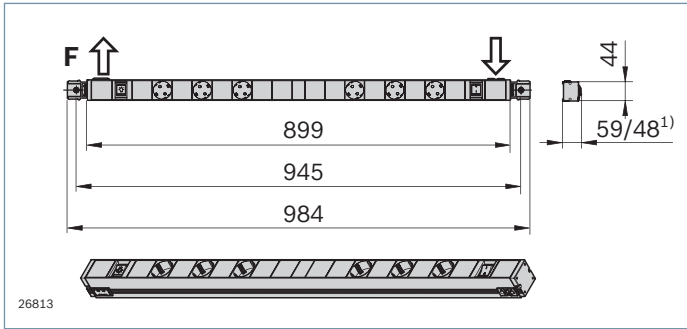
Required accessories: Mains/connection cable (page 2-39 f.)



26812

		Current (A)/Voltage (V)	L x W x H (mm)	No.
<b>A</b> Socket strip 	D	Max. 16 A/230 V	263 x 44 x 48	<b>3 842 539 842</b>
	F	Max. 16 A/230 V	263 x 44 x 48	<b>3 842 539 852</b>
	GB	Max. 13 A/230 V	263 x 44 x 48	<b>3 842 539 862</b>
	USA/CAN*	Max. 15 A/125 V	263 x 44 x 59	<b>3 842 539 880</b>
<b>B</b> Socket strip, switchable output 	D	Max. 16 A/230 V	263 x 44 x 48	<b>3 842 539 844</b>
	F	Max. 16 A/230 V	263 x 44 x 48	<b>3 842 539 854</b>
	GB	Max. 13 A/230 V	263 x 44 x 48	<b>3 842 539 864</b>
	CH	Max. 10 A/230 V	263 x 44 x 59	<b>3 842 539 872</b>
	USA/CAN*	Max. 15 A/125 V	263 x 44 x 59	<b>3 842 539 882</b>
<b>C</b> Socket strip, switchable input 	D	Max. 16 A/230 V	263 x 44 x 48	<b>3 842 539 846</b>
	F	Max. 16 A/230 V	263 x 44 x 48	<b>3 842 539 856</b>
	GB	Max. 13 A/230 V	263 x 44 x 48	<b>3 842 539 866</b>
<b>D</b> Socket strip, switchable output, RCD 	D	Max. 16 A/230 V	404 x 44 x 87	<b>3 842 542 060</b>
	F	Max. 16 A/230 V	404 x 44 x 87	<b>3 842 539 858</b>
Socket strip, RCD 	D	Max. 16 A/230 V	404 x 44 x 87	<b>3 842 558 636</b>
<b>E</b> RCD residual-current device 	EU	Max. 16 A/230 V	233 x 44 x 87	<b>3 842 552 214</b>

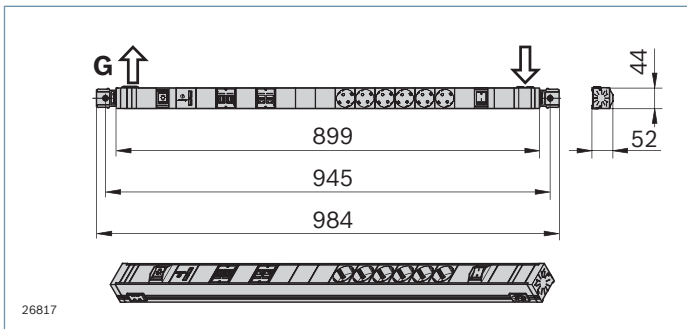
\*UL and CSA test marks



### Power strip

- ▶ Power strip with six grounded plug sockets for attachment to a strut extension (workstations with B = 990 mm)

<sup>1)</sup> Special country-specific dimensions



### Network strip

- ▶ Network strip with six grounded plug sockets and USB 3.0 socket, LAN (RJ45) port and USB charger for attachment to a strut extension (workstations with B = 990 mm)

IP rating: IP 20 (DIN EN IEC 60529)

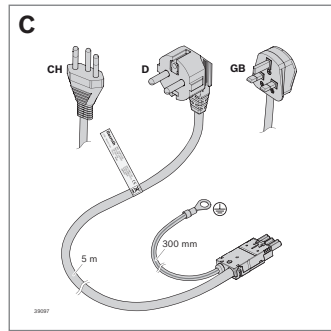
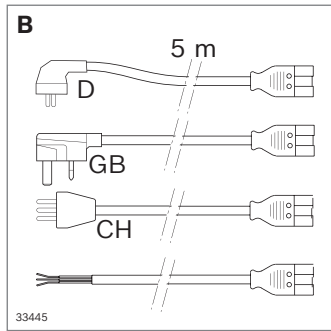
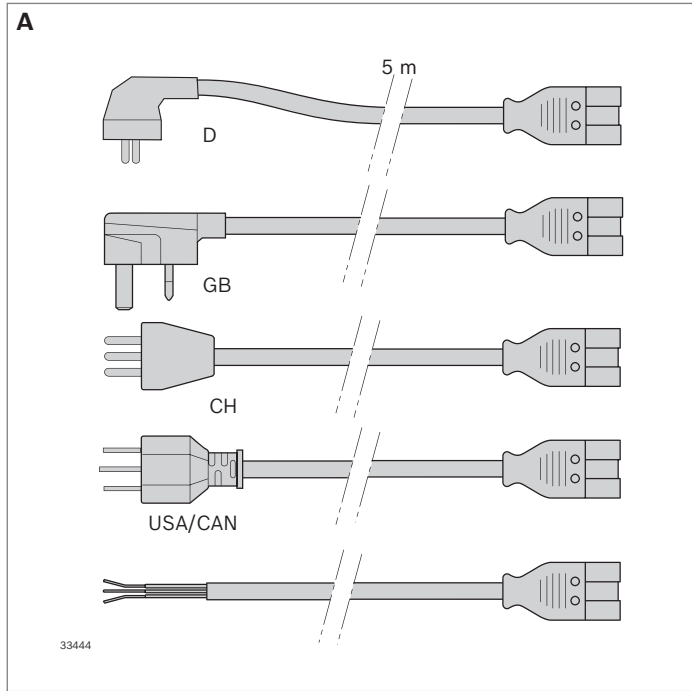
Material: Aluminum, anodized; insert: Plastic, black

Scope of delivery: Includes insulating fastening material (10 mm slot)

Required accessories: Mains/connection cable (page 2-39 f.)

		Current (A)/Voltage (V)	L x W x H (mm)	No.
<b>F</b> Power strip, switchable input, Switchable output 	D	Max. 16 A/230 V	899 x 44 x 48	<b>3 842 539 850</b>
	F	Max. 16 A/230 V	899 x 44 x 48	<b>3 842 539 860</b>
	GB	Max. 13 A/230 V	899 x 44 x 48	<b>3 842 539 868</b>
	CH	Max. 10 A/230 V	899 x 44 x 59	<b>3 842 539 876</b>
	USA/CAN*	Max. 15 A/125 V	899 x 44 x 59	<b>3 842 539 884</b>
<b>G</b> Network strip, switchable input, Switchable output 	D	Max. 16 A/230 V	899 x 52 x 52	<b>3 842 552 212</b>

\*UL and CSA test marks



## Mains and connection cable , connections

### Mains cable (A)

- ▶ Ready-to-use mains cable: In various country versions; for simple, secure plug-and-play installation with no electrician needed
- ▶ For connecting system lamps, socket strips or power strips
- ▶ Open-ended mains cable: For self-assembly

Accessories: GST plug

Material: Connection line EU: PVC (H05VV-F); black

Connection line USA/CAN: PVC (SJTOW); black

### HD mains cable (B)

- ▶ Use in moderate industrial environments
- ▶ For connecting system lamps, socket strips or power strips
- ▶ Open-ended mains cable: For self-assembly

Accessories: GST plug

Material: Connection line PUR (H07BQ-F); orange

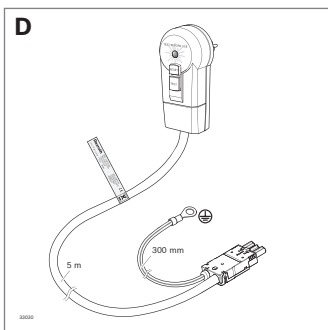
### Mains cable HD with PE connection (C)

- ▶ Use in moderate industrial environments
- ▶ Accessories: GST plug

Connection cable material: PUR (H07BQ-F), orange

	Version	Length (m)	No.
<b>A</b> Mains cable	D/F	5	<b>3 842 517 045</b>
	GB	5	<b>3 842 522 585</b>
	CH	5	<b>3 842 523 910</b>
	USA/CAN*	5	<b>3 842 537 323</b>
	Open end	5	<b>3 842 517 201</b>
<b>B</b> HD mains cable	D/F	5	<b>3 842 554 183</b>
	GB	5	<b>3 842 555 603</b>
	CH	5	<b>3 842 555 605</b>
	Open end	5	<b>3 842 555 607</b>
	<b>C</b> Mains cable HD with PE connection	D/F	5
CH		5	<b>3 842 564 085</b>
GB		5	<b>3 842 564 086</b>

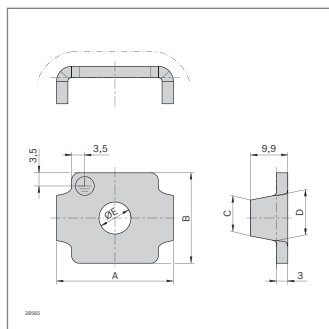
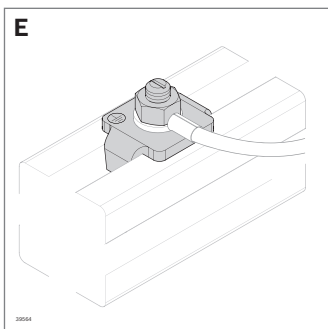
\*UL and CSA test marks



**Mains cable with RCD module and PE connection (D)**

- ▶ For secure connection of workstations directly from the socket
- ▶ RCD module:  $I_{\Delta n} = 30 \text{ mA}$
- ▶ IP rating: IP 20 (DIN EN IEC 60529)

Connection cable material: PUR (H07BQ-F); orange

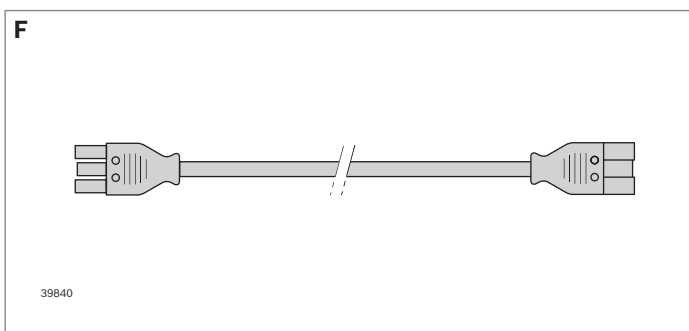


**PE conductor connection 8 mm and 10 mm slot (E)**

- ▶ PE conductor connection set for profile structures for the secure connection of a PE connection in Rexroth profile slots

Scope of delivery: Set incl. fastening material

A (mm)	B (mm)	C (mm)	D (mm)	E (mm)	No.
28	21	7.5	9.3	6.5	<b>3 842 564 106</b>
31	24	9.5	12	8.5	<b>3 842 564 107</b>



**Connection cable (F)**

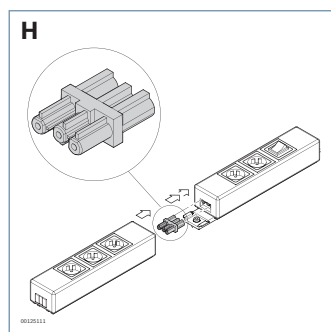
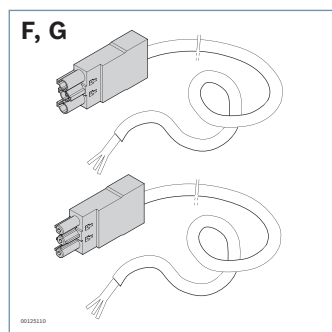
- ▶ For cable connections between system lamps economic, socket strips or power strips
- ▶ Ready-made in various country versions and lengths
- ▶ For simple and secure plug-and-play installation

Color: Black

2

		Version	Length (m)	No.
D	Mains cable with RCD module and PE connection	D/F	5	<b>3 842 555 600</b>
E	PE conductor connection		8 mm slot	<b>3 842 564 106</b>
			10 mm slot	<b>3 842 564 107</b>
F	Connection cable	EU	4	<b>3 842 537 598</b>
			3	<b>3 842 527 207</b>
			2	<b>3 842 517 047</b>
			1.5	<b>3 842 537 123</b>
			1	<b>3 842 517 049</b>
			0.5	<b>3 842 517 051</b>
		USA/CAN*	4	<b>3 842 537 599</b>
			3	<b>3 842 537 558</b>
			2	<b>3 842 537 560</b>
			1.5	<b>3 842 537 562</b>
	1	<b>3 842 537 564</b>		
	0.5	<b>3 842 537 566</b>		

\*UL and CSA test marks



**GST plug, GST socket (F, G)**

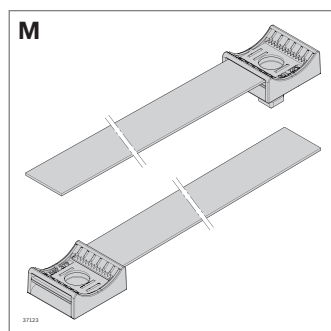
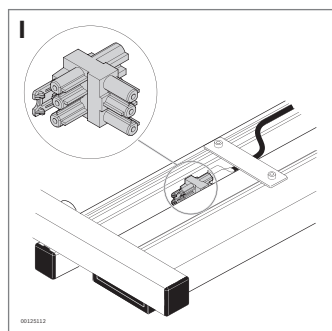
- ▶ For cable self-assembly
- ▶ Color: Black

**Connecting plug**

**T-plug (I)**

**Plug-and-socket lock (J)**

- ▶ For extending connection cables to standard

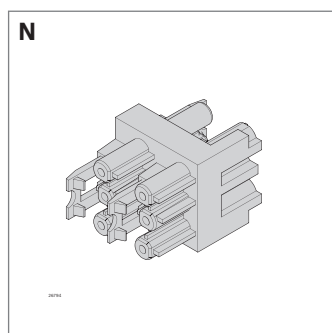


**GST socket locking pieces (K)**

**GST plug locking pieces (L)**

**Loop cable bracket (M)**


- ▶ Cable bracket with Velcro strap for the sparing guidance of cables and hoses.
- ▶ Cable brackets with foot can be screwed into the slot without tools Installation parallel or vertical to the slot possible
- ▶ Loop flat cable bracket for the installation on panel elements or on EcoShape installation base



**See also the Bosch Rexroth cable duct range, MGE 14.0 Basic Mechanic Elements, chapter 11**

**POWER H-distributor (230 V) (N)**

- ▶ For connecting up to three economic lamps to one mains connection
  - ▶ Compatible with 45 x 45 or cable duct (see MGE 13.2)
- Color: Black

	Version		No.
<b>F</b> GST plug		10	<b>3 842 517 043</b>
<b>G</b> GST socket		10	<b>3 842 517 044</b>
<b>H</b> Connecting plug		10	<b>3 842 517 055</b>
<b>I</b> T-plug		10	<b>3 842 532 909</b>
<b>J</b> Plug-and-socket lock			<b>3 842 554 181</b>
<b>K</b> GST socket locking piece			<b>3 842 555 621</b>
<b>L</b> GST plug locking piece			<b>3 842 555 622</b>
<b>M</b> Cable bracket	Loop flat	10	<b>3 842 559 380</b>
	Loop 8	10	<b>3 842 559 381</b>
	Loop 10	10	<b>3 842 559 382</b>
	Adapter D28L	10	<b>3 842 562 115</b>
<b>N</b> POWER H-distributor (230 V)		1	<b>3 842 564 097</b>



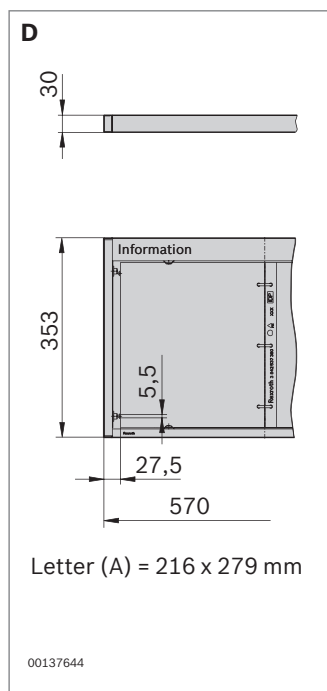
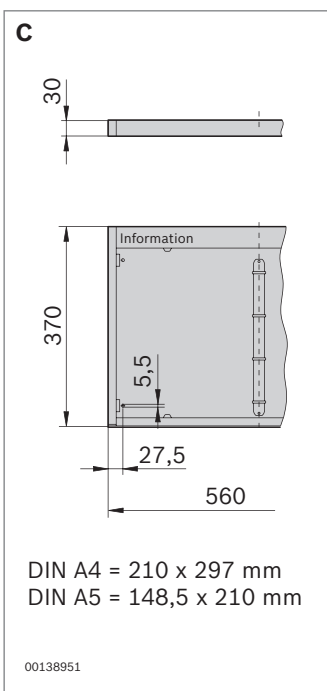
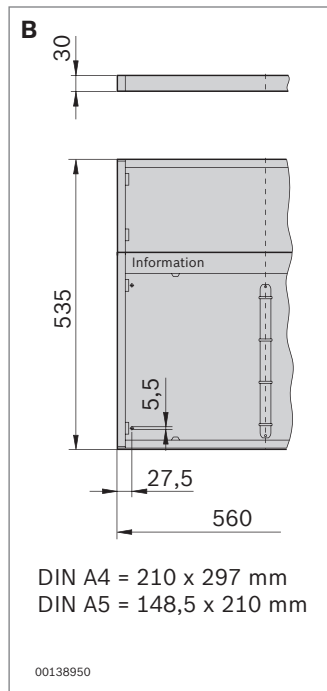
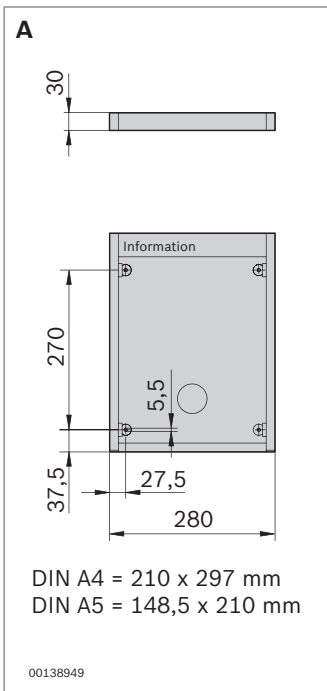
## Information boards



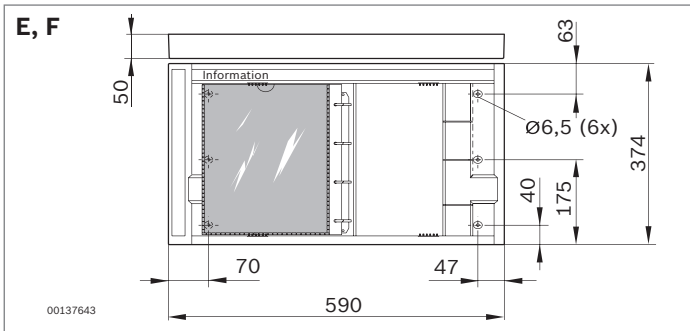
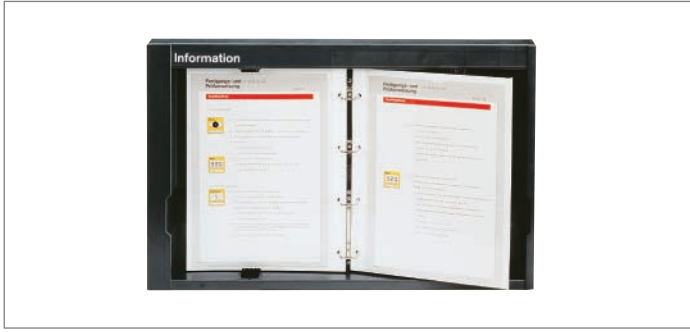
- ▶ For providing information at the workstation, in the material shuttle or on the supermarket shelf
- ▶ High stability
- ▶ Can be mounted horizontally or vertically
- ▶ A4 information board (A): One-sided version
- ▶ 2x A4 plus information board (B): Two-sided version with 4-ring mechanism, DIN A4; insert areas for notice boards
- ▶ 2x A4 EU information board (C): Two-sided version with 4-ring mechanism, DIN A4
- ▶ 2x A4 US information board (D): Two-sided version with 3-ring mechanism, letter
- ▶ ESD version for use at ESD workstations

Material: Frame profile: Aluminum; anodized, natural back panel and board: Sheet steel; powder-coated, anthracite gray RAL 7016, dust gray, RAL 7037 (ESD)  
 Scope of delivery: Includes fastening material (10 mm slot); neutral-colored, self-adhesive text holder; reinforced transparent plastic sleeve (**A**: 1; **B**, **C**, **D**: 2)  
 Required accessories: Transparent plastic sleeve (page 2-43)

2



	ESD	No.
<b>A</b> A4 information boards	EU	<b>3 842 502 151</b>
<b>B</b> Information boards 2x A4 plus	EU	<b>3 842 502 154</b>
<b>C</b> Information boards 2x A4	EU	<b>3 842 502 153</b>
	⚠	<b>3 842 537 870</b>
<b>D</b> Information boards 2x letter	USA	<b>3 842 538 789</b>
	⚠	



## ISO information boards



- ▶ Inexpensive plastic version
- ▶ Can be mounted horizontally or vertically
- ▶ 2xA4 EU information board (E): Two-sided version with 4-ring mechanism for 18 reinforced transparent plastic sleeves, DIN A4 format
- ▶ 2xA4 US information board (F): Two-sided version with 3-ring mechanism for 18 reinforced transparent plastic sleeves, letter format

Material: ABS; anthracite gray, RAL 7016

Scope of delivery: Includes fastening material, set of labels in several languages, reinforced transparent plastic sleeve




Accessories: Transparent plastic sleeve (see below)

		No.
<b>E</b>	2x A4 ISO information boards EU	<b>3 842 517 163</b>
<b>F</b>	2x Letter ISO information boards USA	<b>3 842 517 164</b>

## Transparent plastic sleeve

- ▶ Transparent plastic sleeve fits information board and ISO information board
- ▶ Reinforced version
- ▶ DIN A4: With 4 holes for EU version
- ▶ Letter: With 3 holes for US version
- ▶ ESD version: Long-lasting conductivity, conduction resistance (R) =  $10^4 \dots 10^{11} \Omega$ . ESD conductivity can be reduced by UV rays, heat and chemicals. A yearly check is recommended.

Material: PVC

		 <b>ESD</b>	No.
A4 transparent plastic sleeve EU		10	<b>3 842 539 838</b>
		10 	<b>3 842 537 358</b>
Letter transparent plastic sleeve USA		10	<b>3 842 539 839</b>
		10 	<b>3 842 537 360</b>

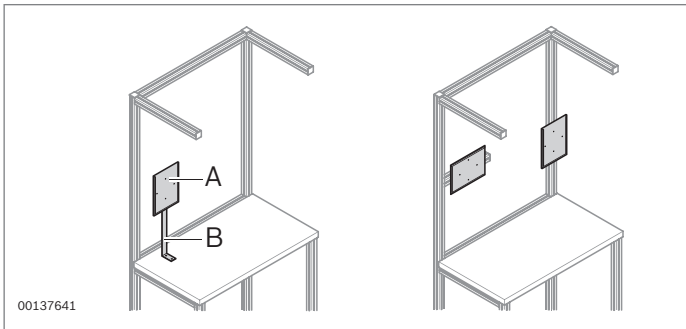


## Slide-in holder

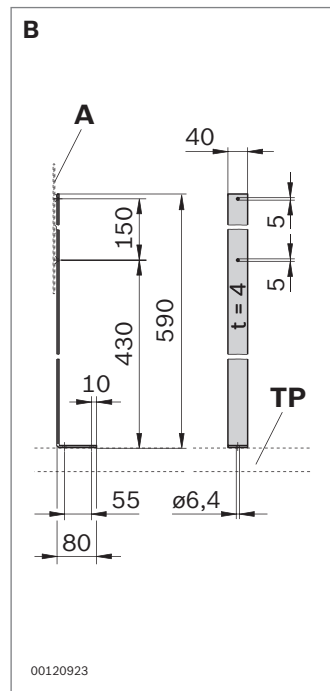
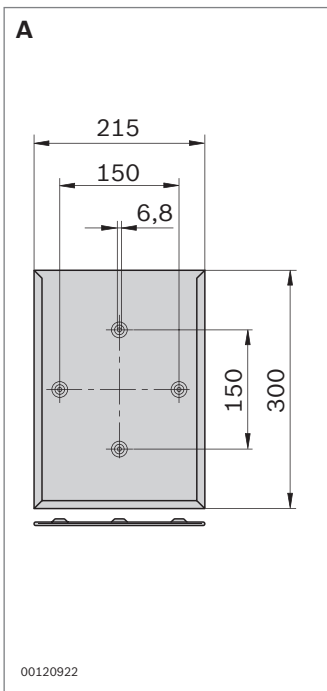
- ▶ For providing individual information sheets in DIN A4 format, e.g., work sequence cards
- ▶ Can be mounted horizontally or vertically
- ▶ Protective pane keeps information clean
- ▶ Holder for fixing to table top

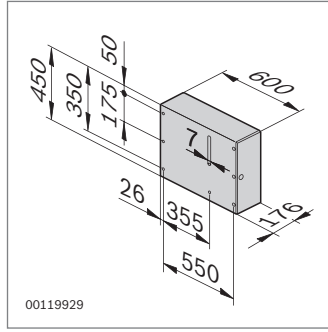
Color: Light gray; RAL 7035

Required accessories: Bolts



	No.
<b>A</b> Slide-in holder	<b>1 845 410 015</b>
<b>B</b> Holder	<b>3 842 000 058</b>





## Cabinet

- ▶ Installation on left or right side
- ▶ Lockable door, extendable tool deposit
- ▶ Assembly on table frame (slot spacing 550 mm)

Material: Sheet steel; light gray, RAL 7035

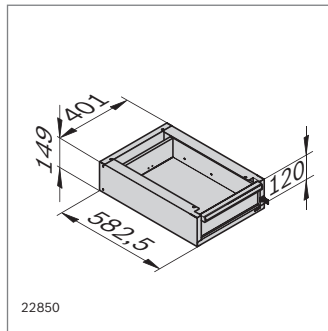
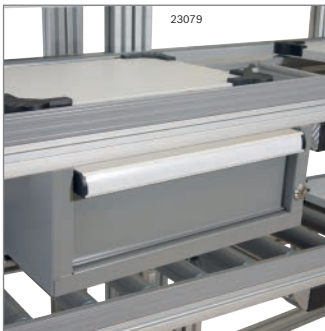
Scope of delivery: Incl keys, transparent shelf cabinet

Required accessories:

M6 T-nut (3 842 530 285, page 2-53);

M6x14 DIN 912 screw; DIN 125 washer

	Version	No.
Cabinet	Installation on left side	<b>3 842 028 621</b>
	Installation on right side	<b>3 842 028 620</b>



## Base drawer



- ▶ Soft-closing, easy-to-close drawers with ball bearing; automatic closing
- ▶ Lockable drawer
- ▶ Ergonomic aluminum handle bar with label field
- ▶ Permissible drawer load: 350 N
- ▶ ESD version
- ▶ Mounting (suspended):
  - on table frame
  - on table top

ESD material: Sheet steel; dusty gray, RAL 7037

Scope of delivery: Includes drilling template,

fastening material, key

	ESD	No.
Base drawer		<b>3 842 546 533</b>



23076

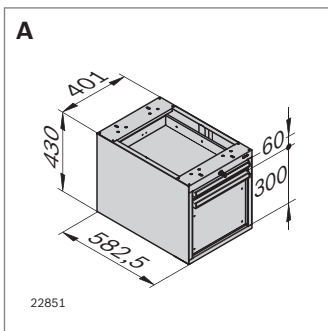
## Drawer cabinet Containers



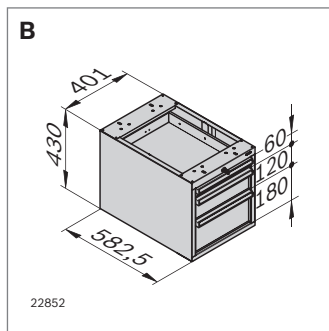
### Drawer cabinet (A, B)

- ▶ Soft-closing, easy-to-close drawers with ball bearing; automatic closing
- ▶ Ergonomic aluminum handle bar with label field
- ▶ All drawers can be locked at same time
- ▶ Permissible load
  - per drawer: 350 N
  - total per drawer cabinet: 850 N
- ▶ Available as ESD-conductive version
- ▶ Mounting (suspended):
  - on table frame
  - on table top

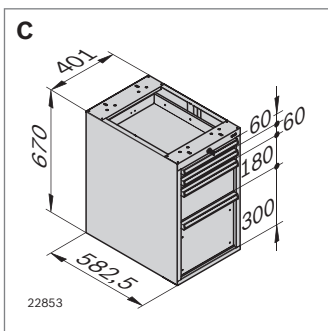
Material: Sheet steel; light gray, RAL 7035  
 ESD material: Sheet steel; dusty gray, RAL 7037  
 Scope of delivery: Includes drilling template, fastening material, key



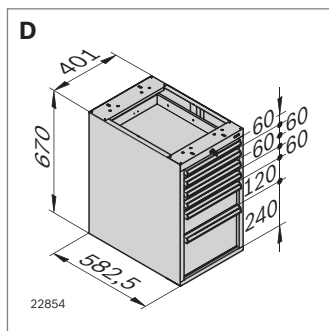
22851



22852



22853



22854

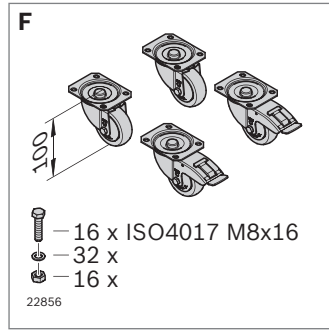
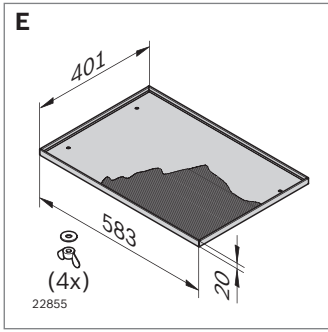
### Containers (C, D)

- ▶ Soft-closing, easy-to-close drawers with ball bearing; automatic closing
- ▶ Ergonomic aluminum handle bar with label field
- ▶ All drawers can be locked at same time
- ▶ Permissible load
  - per drawer: 350 N
  - total per container: 1300 N
- ▶ Available as ESD-conductive version
- ▶ Fitted with castors, e.g. for setting up next to workstation

Material: Sheet steel; light gray, RAL 7035  
 ESD material: Sheet steel; dusty gray, RAL 7037  
 Scope of delivery: Includes drilling template, fastening material, key  
 Required accessories: Cover (E), castors (set) (F)

	Version	ESD	No.
A	Drawer cabinet	2 drawers	<b>3 842 546 534</b>
			<b>3 842 546 538</b>
B	Drawer cabinet	3 drawers	<b>3 842 546 535</b>
			<b>3 842 546 539</b>
C	Containers	4 drawers	<b>3 842 547 886</b>
			<b>3 842 546 540</b>
D	Containers	6 drawers	<b>3 842 547 887</b>
			<b>3 842 559 392</b>

For technical data, see page 13-9



**Cover for container (E)**

Cover material: Sheet steel; powder-coated, RAL 7035 (light gray)

ESD cover material: Sheet steel; powder-coated, RAL 7037 (dusty gray)

Scope of delivery: Incl fastening material

**Castors for container (F)**

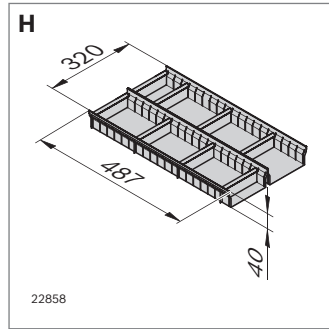
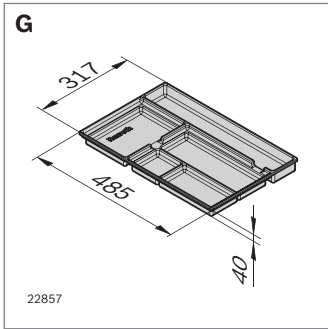
- Set of two castor wheels and two castor wheels with stop

Housing material: Sheet steel; zinc-plated

Wheel body material: PP

Wheel running surface material: Thermoplastic rubber

Scope of delivery: Incl fastening material

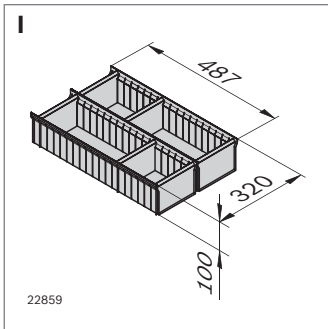


**Drawer insert (G, H, I)**

- Fixed arrangement (**G**)
- Variable arrangement (**H, I**), bending plate can be opened

Material (**G**): ABS; black

Material (**H, I**): Sheet steel; zinc-plated



	h (mm)		ESD	No.
<b>E</b> Cover for container				<b>3 842 546 542</b>
				<b>3 842 546 543</b>
<b>F</b> Castors for container (Ø 80 mm)		Set		<b>3 842 547 885</b>
				<b>3 842 546 541</b>
<b>G</b> Drawer insert	40			<b>3 842 548 900</b>
<b>H</b> Drawer insert, variable arrangement	40			<b>3 842 546 546</b>
<b>I</b> Drawer insert, variable arrangement	100			<b>3 842 546 547</b>



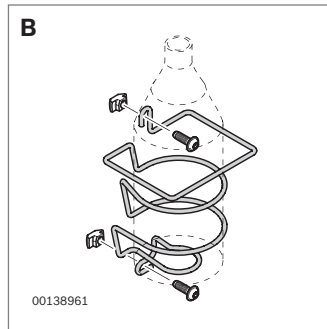
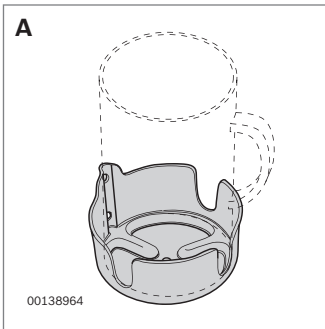
## Holder



### Cup holder (A)

Material: PA66, black

Required accessories: M5 T-nuts for 10 mm slot

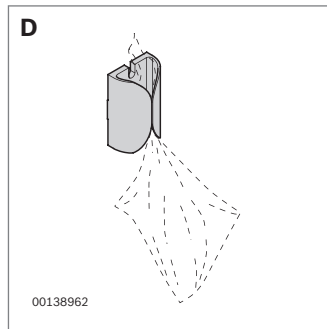
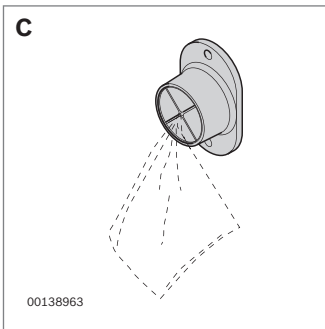


### Bottle holder (B)

► Accommodates bottles and rectangular drink cartons

Material: Steel wire; powder-coated; RAL 7037 light gray

Scope of delivery: Includes fastening material (10 mm slot)



### Cloth holder (C, D)

► For hanging cleaning cloths

► Cloth holder D with clamp base for direct assembly on strut profile with 10 mm slot

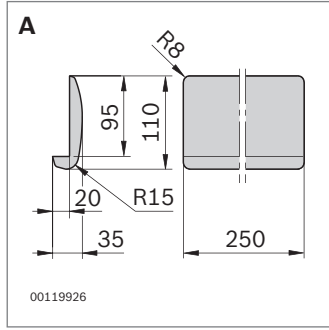
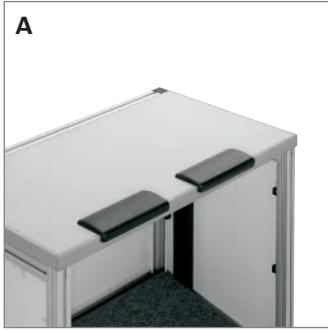
Color: Black

Required accessories (for C):

M5 T-nuts for 10 mm slot;

M5x12 8.8 DIN 7984 bolts

	ESD	No.
<b>A</b> Cup holder		<b>3 842 513 722</b>
<b>B</b> Bottle holder		<b>3 842 540 429</b>
<b>C</b> Cloth holder		<b>1 845 719 000</b>
T-nut for 10 mm slot	100	<b>3 842 530 203</b>
<b>D</b> Cloth holder with clamp base		<b>3 842 530 306</b>



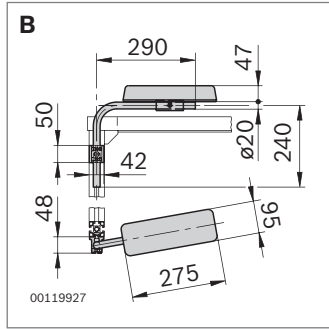
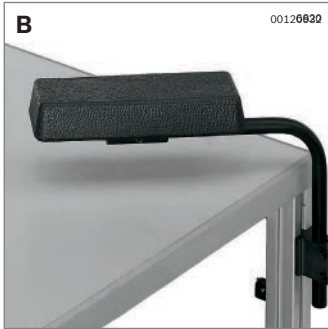
## Armrest



### Armrest (A)

- ▶ Soft support pads protect wrists and arms
- ▶ ESD version: Conductive. ESD conductivity can be reduced by UV rays, heat, wear and chemicals. A yearly check is recommended.

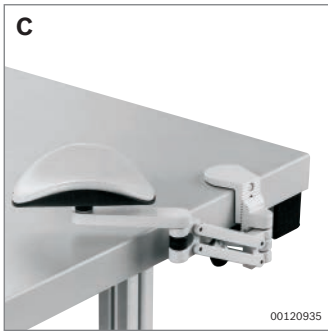
Material: Flexible PUR foam; black  
 Required accessories: Double-sided tape (Copper tape for ESD version) for fixing to table top



### Adjustable armrest (B)

- ▶ Relieves arm strain during assembly work
- ▶ Fastened to table frame; suitable for all Rexroth box type workstation construction

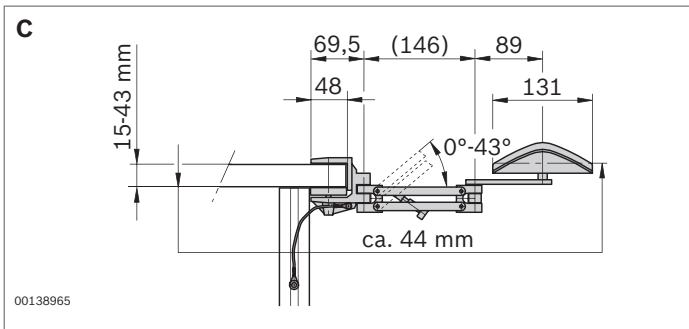
Pad material: Flexible PUR foam; black  
 Scope of delivery: Includes fastening material (10 mm slot)



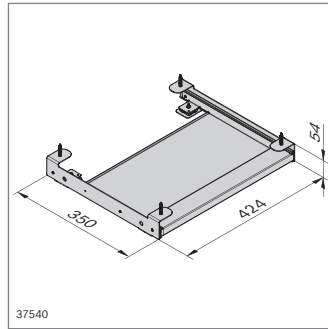
### Armrest with pad (C)

- ▶ Relieves arm strain during assembly work
- ▶ Hinges allow precisely controlled movements
- ▶ Clamp attachment to table top
- ▶ ESD version for use at ESD workstations

Pad material: Leather; white  
 ESD pad material: Leather; black



	ESD	No.
A Armrest		3 842 191 186
		3 842 516 704
B Adjustable armrest		3 842 191 178
C Armrest with pad		3 842 515 493
		3 842 515 525



## Keyboard shelf

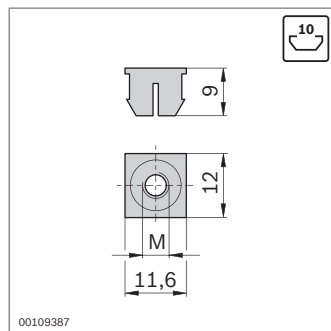
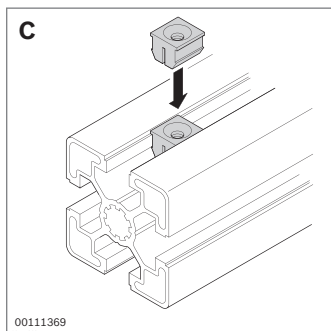
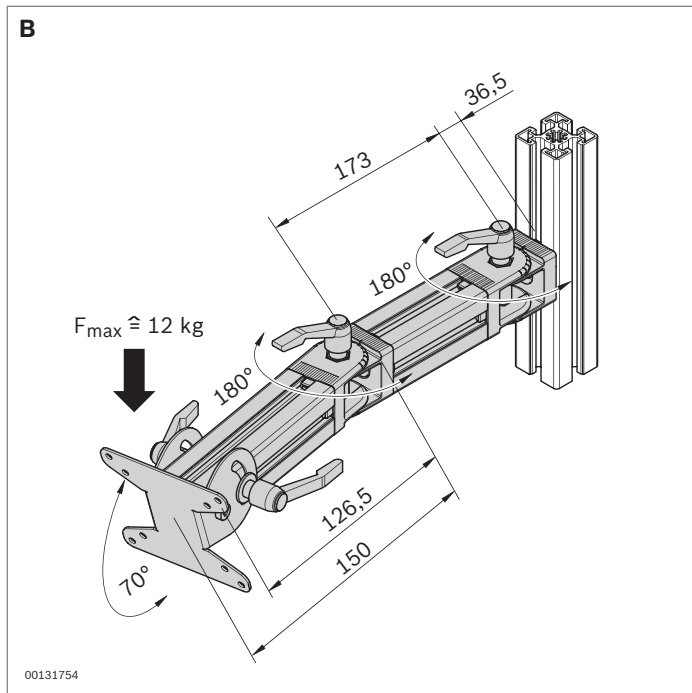
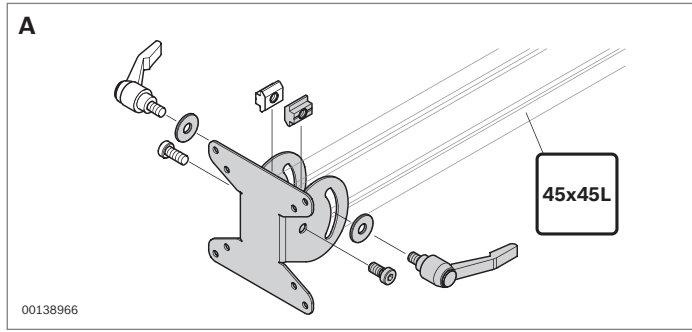
- ▶ For secure, space-saving storage of keyboards at the workstation
- ▶ Max. keyboard dimensions: 400x205x35 mm
- ▶ Perfect for keyboards with touch pad
- ▶ For installation underneath a table top
- ▶ Telescopic rails with locking function in the extended and retracted condition
- ▶ With ergonomic hand rest

Keyboard shelf material: Sheet steel; painted, light gray (RAL 7035)

Pull-out rail material: Steel

Scope of delivery: Incl. fastening material for mounting underneath the table top

	<b>No.</b>
Keyboard shelf	<b>3 842 558 454</b>



## TFT monitor bracket



- ▶ TFT monitor bracket (**A**) with VESA hole pattern (75x75 mm and 100x100 mm) for mounting a TFT monitor on a 45x45L profile
- ▶ Swivel range: 70°
- ▶ TFT monitor bracket with supporting arm (**B**) can be swiveled and horizontally adjusted. Enables ergonomically ideal positioning of the screen.

Scope of delivery **A**: Includes fastening material (10 mm slot)

Scope of delivery **B**: Includes supporting arm (45x45L profile, DesignLINE joints); includes fastening material (10 mm slot)

	No.
<b>A</b> TFT monitor bracket	<b>3 842 539 840</b>
<b>B</b> TFT monitor bracket with supporting arm	<b>3 842 539 806</b>

## Expanding nut

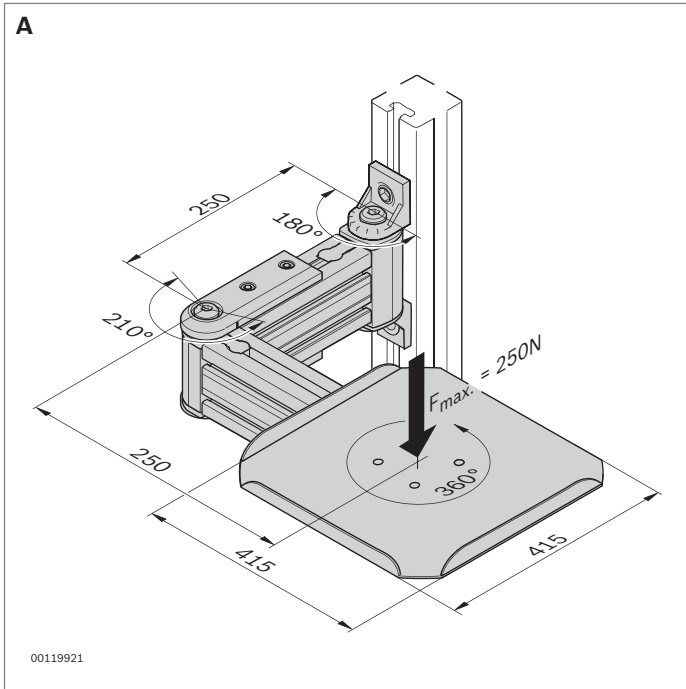


- ▶ For attaching light accessories such as cable ties or rings
- ▶ Easy assembly by clipping into the profile slot
- ▶ Profile finishing: Not required

Required accessories: Countersunk screw

Material: PA; signal gray similar to RAL 7004

	Slot	M		No.
<b>C</b> Expanding nut	10	M4	100	<b>3 842 554 774</b>
		M5	100	<b>3 842 554 776</b>
		M6	100	<b>3 842 554 778</b>

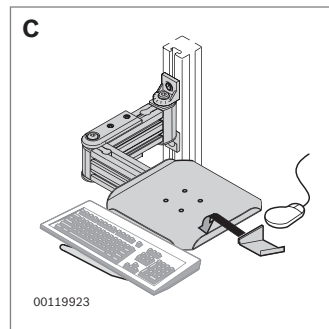
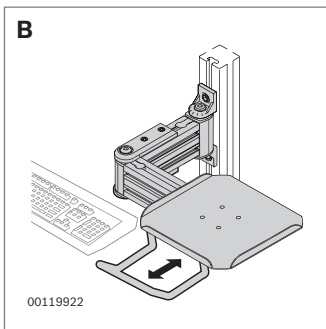


## Supporting arm



- ▶ For space-saving positioning of a monitor or material container at the workstation
- ▶ Multiple hinges

Scope of delivery: Includes fastening material (10 mm slot)



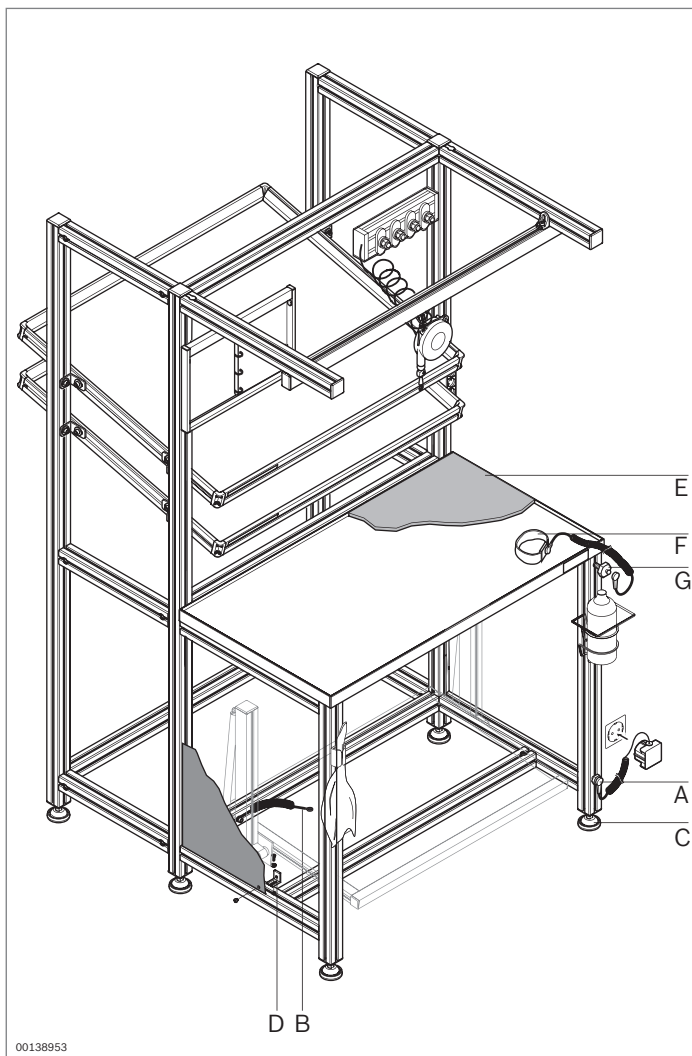
## Keyboard holder

- ▶ Extendable
- ▶ Suspends on supporting arm

## Mouse holder

Suspends on supporting arm

	No.
<b>A</b> Supporting arm	<b>3 842 521 970</b>
<b>B</b> Keyboard holder	<b>3 842 522 305</b>
<b>C</b> Mouse holder	<b>3 842 522 130</b>










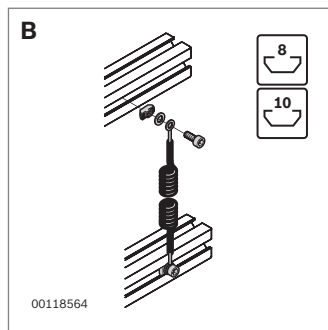
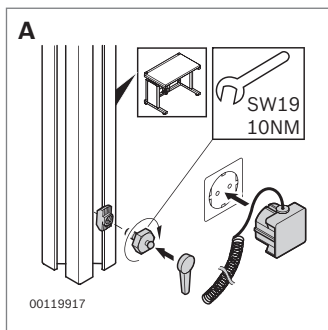
00138953

### Components for ESD applications



- A Set of grounding components
- B Grounding cable
- C Damping ring
- D Potentialfix
- E Conductive mat insert
- F Wrist band

	 <b>ESD</b>	<b>No.</b>
<b>A</b> Set of grounding components		<b>3 842 522 087</b>
<b>B</b> Grounding cable		<b>3 842 519 465</b>
<b>C</b> Damping ring, insulating	20	<b>3 842 521 817</b>
<b>D</b> Potentialfix		<b>3 842 536 320</b>
<b>E</b> ESD mat insert		<b>3 842 522 012</b>
<b>F</b> Wrist band		<b>3 842 516 908</b>
<b>G</b> Connection piece	10	 <b>3 842 516 905</b>



### Set of grounding components (A)

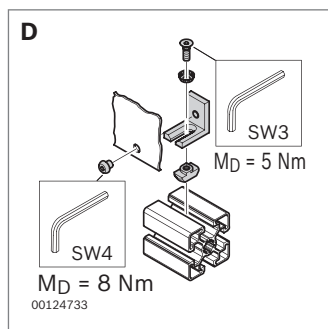
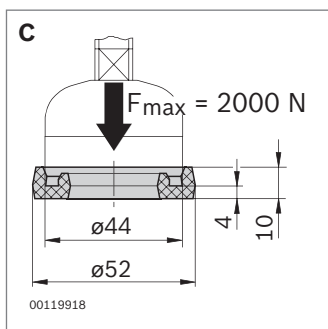
- ▶ For defined grounding of ESD workstations
- ▶ Conduction resistance (R) =  $1 \times 10^6 \Omega$

Scope of delivery: Includes fastening material (10 mm slot)

### Grounding cable (B)

- ▶ To create defined conductive paths between strut profiles to protect ESD-sensitive components
- ▶ Total length 1200 mm

Scope of delivery: Includes fastening material (10 mm slot/10 mm slot), (10 mm slot/8 mm slot)



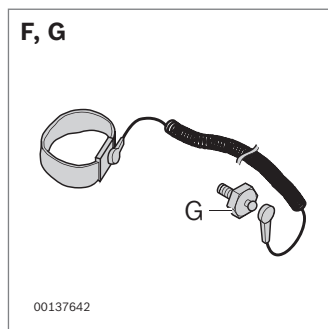
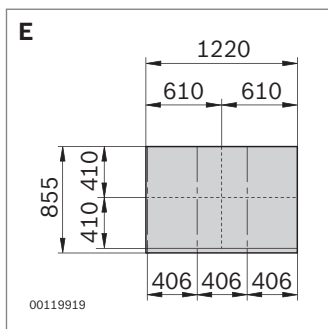
### Damping ring (C)

- ▶ Insulates frames from conductive floors, protects floors and prevents vibrations from being transmitted

Material: PUR; resistant to oils and organic solvents

Color: Natural

Hardness: 70-80 Shore A



### Potentialfix (D)

- ▶ For defined grounding of panel elements such as side panels

### Conductive mat insert (E)

- ▶ To protect ESD-sensitive components
- ▶ To create a safe conductive connection, e.g., to ESD material shelves, we recommend using adhesive copper tape.
- ▶ Conduction resistance (R) =  $10^4 \dots 10^9 \Omega$

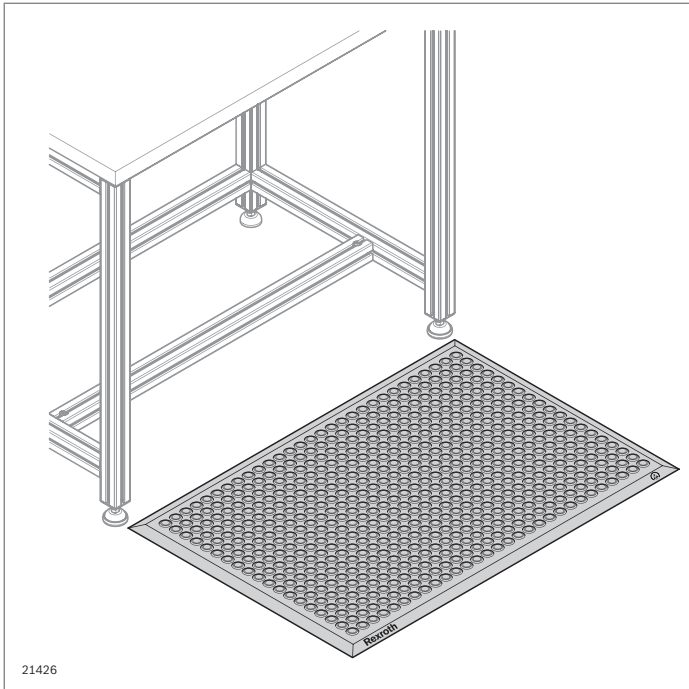
Material: Natural rubber

Format: 1220 x 855 x 2 mm

### Wrist band (F)

- ▶ Wrist band (F) with connection piece (G) for defined grounding of people and protection of ESD-sensitive components

Required accessories: M6 T-nuts for 10 mm slot (3842530285)



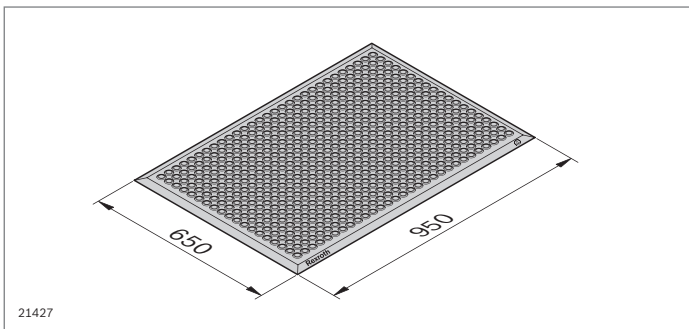
## Ergonomic mat



- ▶ Elastic ergonomic mat cushions employees' movements, reduces strain and protects joints
- ▶ Improved circulation reduces fatigue
- ▶ Use at stand up/moving workstations and machines

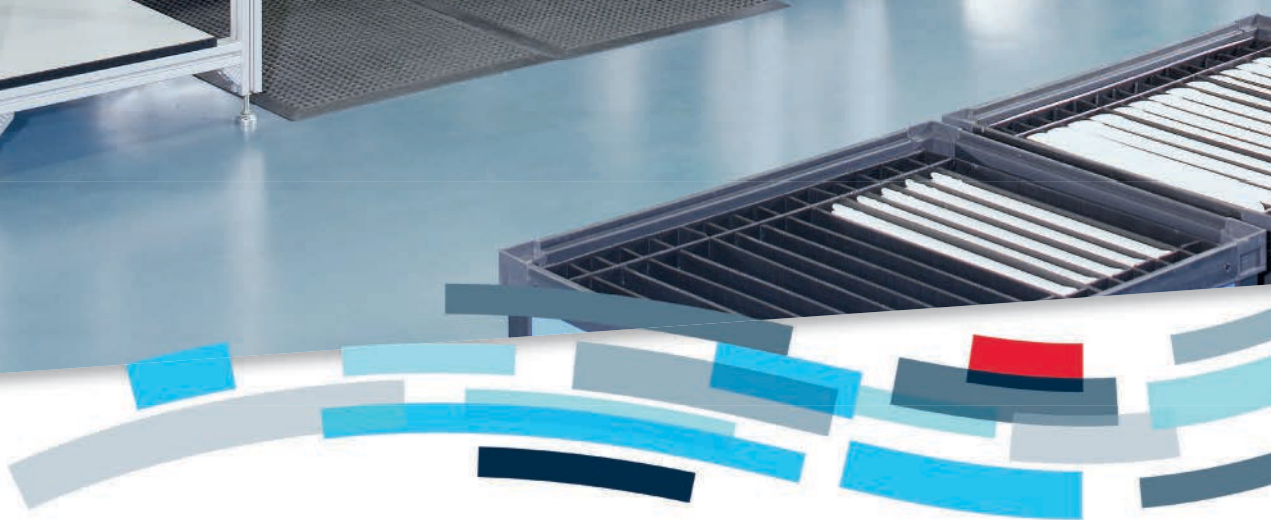
Material: PUR (without CFCs),  
conduction resistance (R) <  $1 \times 10^9 \Omega$

	<b>ESD No.</b>
Ergonomic mat	 <b>3 842 544 789</b>





2





## Shorter grab distances make for faster assembly

**The ergonomic positioning of parts is the key to an efficient workstation. Unnecessary movements add no value and are therefore wasteful. They consume valuable production time and place an additional strain on the worker. This is why all grab distances should be as short as possible.**

Grab containers and parts containers placed in direct reach of the employee are ideal. The containers should be arranged to allow for a flowing, ascending arch sequence of motions based on the body's natural movement. Moreover, two-handed grabbing and joining can cut assembly time by up to 50 %. The ergonomic design of the grab containers based on MTM (Method of Time Measurement) serves to effectively pre-separate the parts: The grab ledges have ridges to enable quick and secure part picking.



### Vario grab containers

For space-saving and ergonomic supply of small parts such as nuts and screws. Vario grab containers are stackable. They are mounted on strut profiles or on a base placed directly on the work surface.

### Plastic grab containers

These plastic grab containers are sturdy and robust. The containers can be exchanged easily. This allows for very fast order picking, part replenishment and workstation conversions. When used in combination with the material shelves at the workstation or in the material shuttle, these grab containers are suited for implementing the two-bin system (Kanban). An ESD-conductive version of the

## GRAB CONTAINER OVERVIEW

- 3-3** Vario grab containers
- 3-5** Filler hopper
- 3-6** Grab containers
- 3-7** Grab trays
- 3-8** Container mount
- 3-8** Labeling clip
- 3-9** Grab container rack application
- 3-10** Grab ledge



grab containers is also available.

Labeling clips for content labeling are included as accessories. Container mounts and the grab container rack are also available for optimally positioning the plastic grab containers.



## Vario grab containers

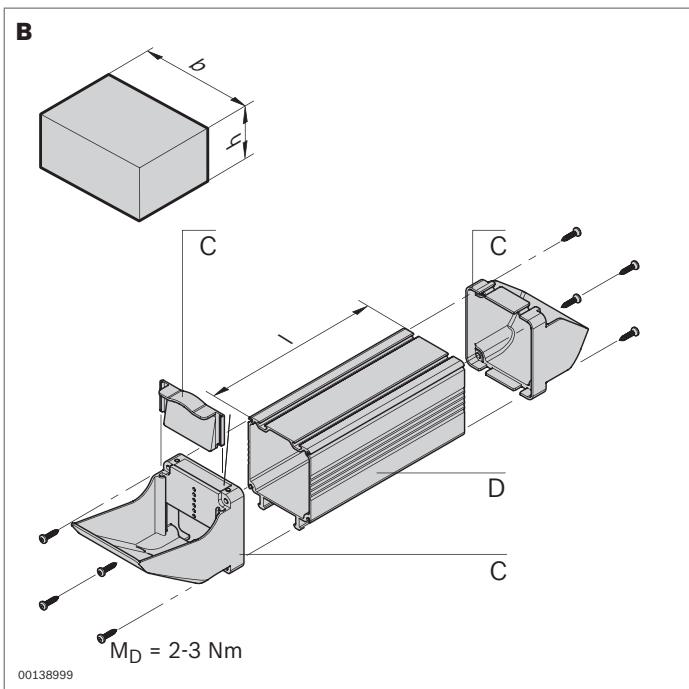
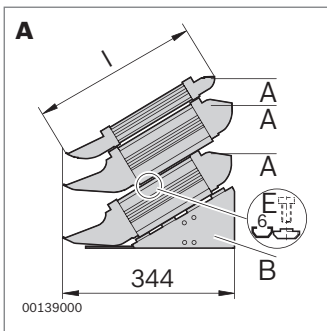


















- ▶ Small parts such as nuts and screws placed within easy reach on the workstation
- ▶ Quick and secure grabbing due to ergonomic grab ledge design based on MTM (Method of Time Measurement)
- ▶ Sturdy, compact stacking for reduced space requirements
- ▶ Vario grab containers in three standard sizes (**A**)
- ▶ Self-assembly elements for custom configurations (aluminum material chute (**D**) + plastic grab ledge and refill end-pieces (**C**)) for varying volumes and quantities
- ▶ Grab container base (**B**) for ergonomically ideal arrangement of grab containers with short grab distances; mounted directly on work top or on strut profile
- ▶ For offsetting grab containers in a stack: M5 sliding block (6 mm slot) and DIN 7984 M5x6 screw

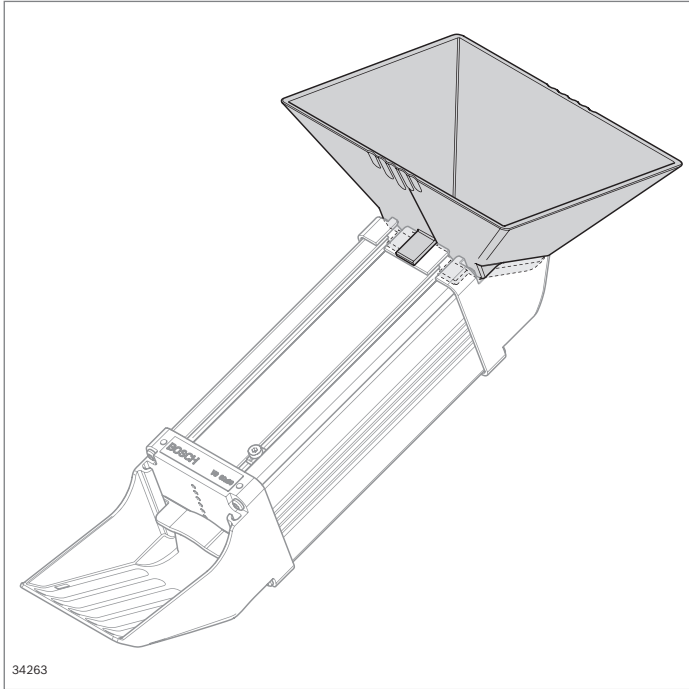
Grab ledge and refill end-piece material: ABS plastic; light gray (similar to RAL 7035); ESD: Black (similar to RAL 9005)

Material chute material: Aluminum; anodized

Grab container base material: Steel sheet; light gray RAL 7035



	<b>Width x height (mm)</b>	<b>Length (mm)</b>	<b>Capacity (cm<sup>3</sup>)</b>	<b>Filling weight (kg)</b>			<b>ESD</b>	<b>No.</b>								
<b>A</b> Vario grab containers	90 x 45	333	500	2.5				<b>3 842 526 621</b>								
								 <b>3 842 558 325</b>								
	90 x 90	375	1300	5.0				<b>3 842 526 622</b>								
								 <b>3 842 558 326</b>								
	180 x 90	375	2900	10.0				<b>3 842 526 623</b>								
								 <b>3 842 558 327</b>								
<b>B</b> Grab container base	90 x 149	315						<b>3 842 526 660</b>								
								 <b>3 842 558 331</b>								
	180 x 149	315						<b>3 842 526 665</b>								
								 <b>3 842 559 310</b>								
<b>C</b> Grab ledge and refill end-piece	90 x 45							<b>3 842 526 626</b>								
								 <b>3 842 558 328</b>								
	90 x 90							<b>3 842 526 627</b>								
								 <b>3 842 558 329</b>								
180 x 90							<b>3 842 526 628</b>									
							 <b>3 842 558 330</b>									
<b>D</b> Material chute	90 x 45	50 ... 3000						<b>3 842 993 071/L</b>								
								 <b>3 842 993 446/L</b>								
								3000		3		<b>3 842 526 671</b>				
								1500		6	 <b>3 842 558 332</b>					
								90 x 90	50 ... 3000						<b>3 842 993 072/L</b>	
															 <b>3 842 993 517/L</b>	
	3000							<b>3 842 526 672</b>								
								1500		6	 <b>3 842 558 333</b>					
	180 x 90	50 ... 3000							<b>3 842 993 073/L</b>							
									 <b>3 842 993 527/L</b>							
									3000		3		<b>3 842 526 673</b>			
									1500		6	 <b>3 842 558 334</b>				
<b>E</b> M5 sliding block (6 mm slot)																<b>3 842 523 142</b>
																100

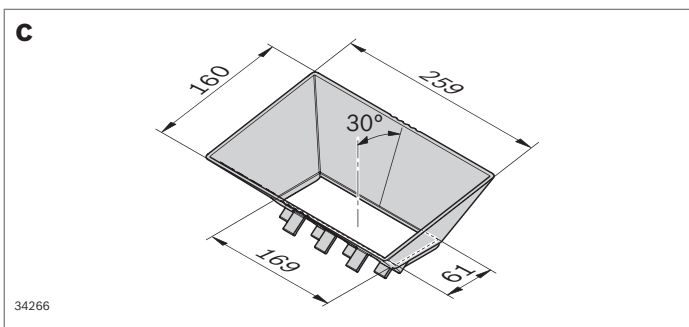
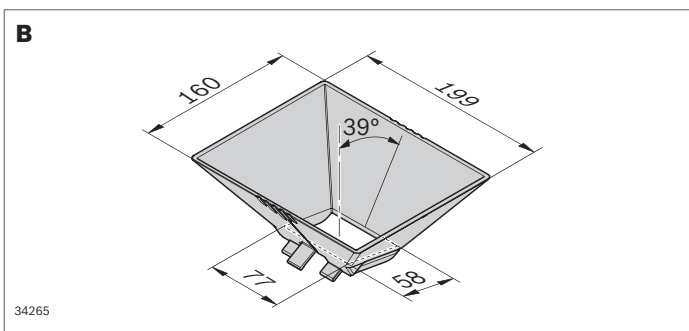
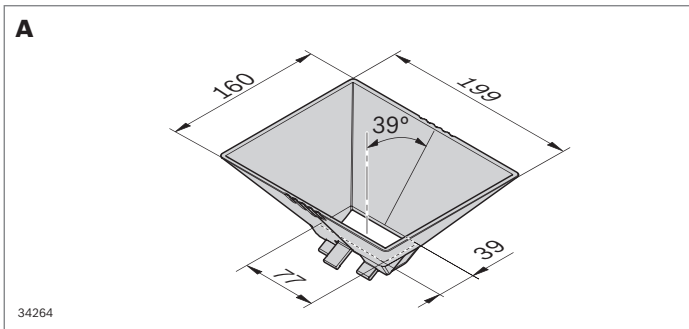


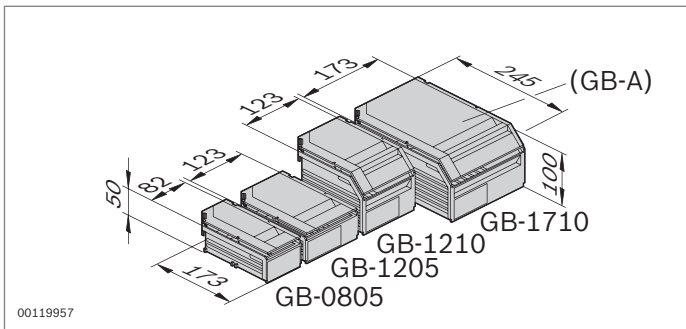
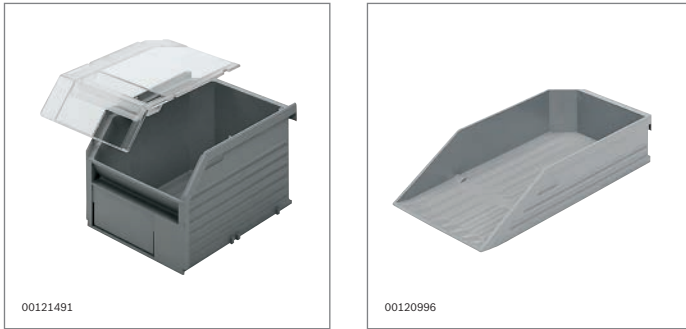
### Filler hopper

- ▶ Hopper for installing on Vario grab container
- ▶ Docking aids on the hopper make it easier to ergonomically fill the Vario grab container with small parts
- ▶ Available for sizes 90x45, 90x90 and 180x90
- ▶ Easy installation and removal of hoppers

Material: ABS plastic; light gray (similar to RAL 7035)

		ESD	No.
<b>A</b>	Hopper 90 x 45	1	<b>3 842 557 433</b>
		⚠	<b>3 842 564 686</b>
<b>B</b>	Hopper 90 x 90	1	<b>3 842 557 434</b>
		⚠	<b>3 842 564 687</b>
<b>C</b>	Hopper 180 x 90	1	<b>3 842 557 435</b>
		⚠	<b>3 842 564 688</b>





## Grab containers



- ▶ Ready access to small parts at the workstation or in the material shuttle
- ▶ Ergonomically designed surface for easy and secure grabbing
- ▶ Can be combined with grab ledge and cover
- ▶ Red grab container for rejects and defective parts

Material: ABS

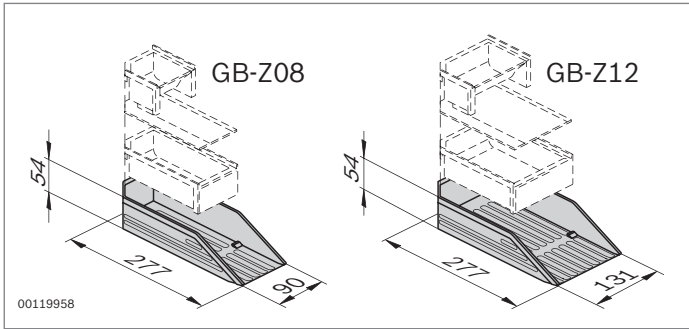
### Cover

- ▶ Protects parts in storage, during transport and at the workstation

Material: Standard: PC; ESD: ABS

	Type	Color	ESD	No.
Grab containers	GB-805	Light gray		<b>3 842 344 750</b>
		Black <sup>1)</sup>		<b>3 842 346 280</b>
	GB-1205	Light gray		<b>3 842 344 751</b>
		Black <sup>1)</sup>		<b>3 842 346 281</b>
	GB-1210	Light gray		<b>3 842 344 752</b>
		Black <sup>1)</sup>		<b>3 842 346 282</b>
	GB-1710	Light gray		<b>3 842 344 753</b>
		Black <sup>1)</sup>		<b>3 842 346 283</b>
	GB-1710	Red <sup>2)</sup>		<b>3 842 555 685</b>
	Cover	GB-A0805	Transparent	
Black <sup>1)</sup>				<b>3 842 346 286</b>
GB-A1205		Transparent		<b>3 842 344 757</b>
		Black <sup>1)</sup>		<b>3 842 346 287</b>
GB-A1210		Transparent		<b>3 842 344 758</b>
		Black <sup>1)</sup>		<b>3 842 346 288</b>
GB-A1710		Transparent		<b>3 842 344 759</b>
		Black <sup>1)</sup>		<b>3 842 346 289</b>
GB-A1710	Red <sup>2)</sup>		<b>3 842 557 478</b>	

<sup>1)</sup> R<sub>gp</sub>/R<sub>pp</sub> = 10<sup>4</sup> ... 10<sup>9</sup> Ω; <sup>2)</sup> R<sub>gp</sub>/R<sub>pp</sub> = 10<sup>8</sup> ... 10<sup>12</sup> Ω



## Grab ledge



- ▶ Separates mixed parts on ergonomically designed grab surface
- ▶ Ridged surface for easy and secure grabbing
- ▶ Time savings of up to 10 %

Material: ABS

		Color	ESD	No.
Grab ledge	GB-Z08	Light gray		<b>3 842 344 760</b>
		Black <sup>1)</sup>		<b>3 842 346 290</b>
	GB-Z12	Light gray		<b>3 842 344 761</b>
		Black <sup>1)</sup>		<b>3 842 346 291</b>

<sup>1)</sup> R<sub>gp</sub>/R<sub>pp</sub> = 10<sup>4</sup> ... 10<sup>9</sup> Ω



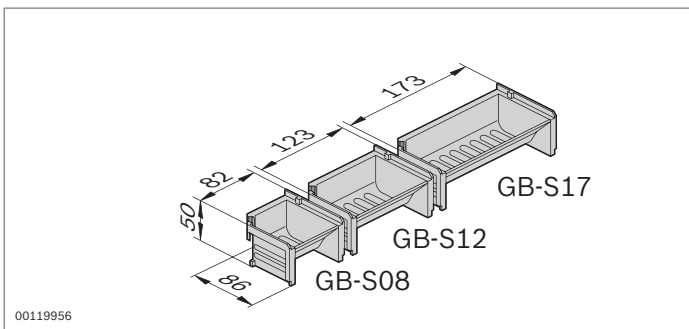
## Grab trays

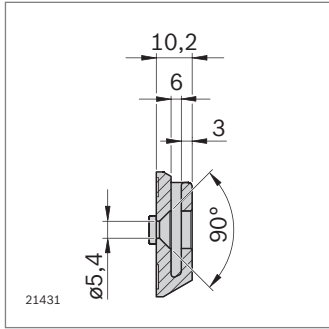
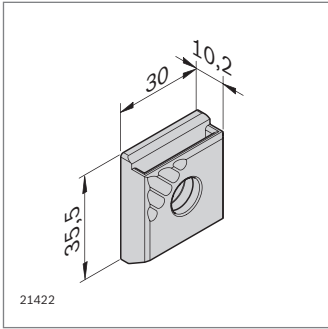
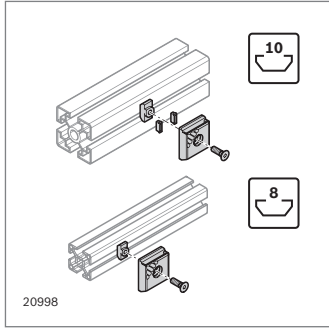


- ▶ Space-saving supply of small parts, e.g., underneath the material feed
- ▶ Wiper lip for easier removal of small parts
- ▶ Fastening

Material: ABS

		Color	ESD	No.
Grab trays	GB-S08	Light gray		<b>3 842 344 764</b>
		Black		<b>3 842 346 294</b>
	GB-S12	Light gray		<b>3 842 344 765</b>
		Black		<b>3 842 346 295</b>
	GB-S17	Light gray		<b>3 842 344 766</b>
		Black		<b>3 842 346 296</b>





**Container mount**



- ▶ Container mount for mounting tool holders, grab containers, grab trays and grab ledges
- ▶ Suitable for 8 mm and 10 mm slot

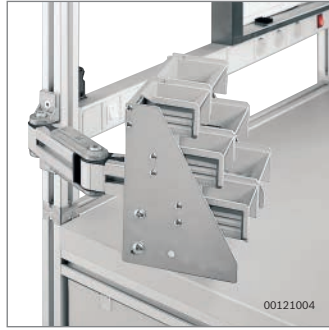
Material: PA 66; black  
 Scope of delivery: Includes fastening material for fastening in 8 mm and 10 mm slots

		ESD	No.
Container mount	10		<b>3 842 544 797</b>

**Labeling clips**

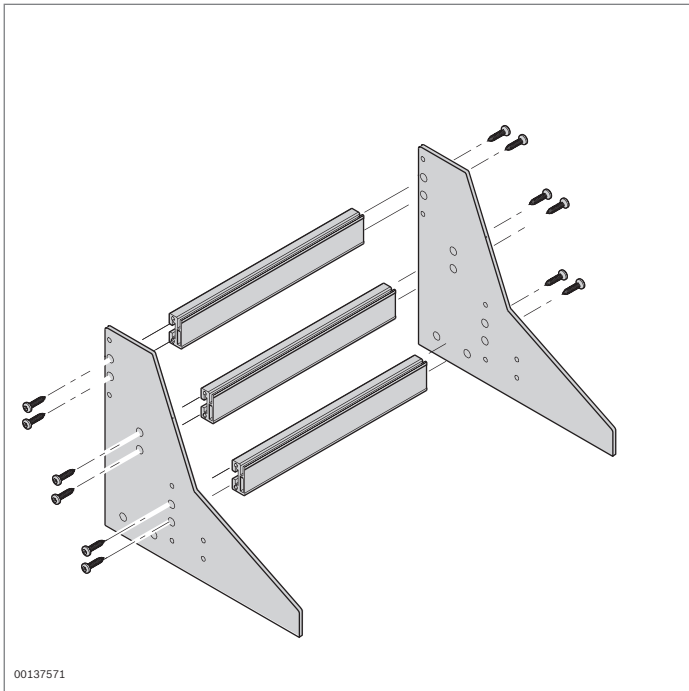
- ▶ Standardized labeling of grab containers
- ▶ Interchangeable labels (74 mm x 37 mm)

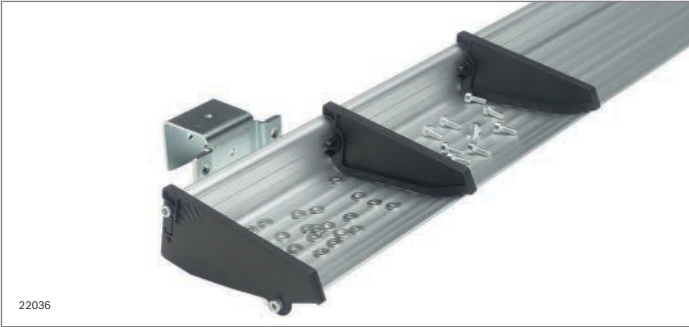
		No.
Labeling clips (incl. labels)	10	<b>3 842 536 127</b>



### Grab container rack application

- ▶ Easy-to-reach, ergonomic supply of materials in grab containers on the workstation
- ▶ Minimized grab distances by positioning materials in direct vicinity of worker
- ▶ Notches for adjusting the height and offset position of the grab containers
- ▶ Can be combined with a swiveling supporting arm (page 2-52)
- ▶ Self-assembly elements for custom configurations of grab container rack in variable widths, see "Components" section (page 12-1)

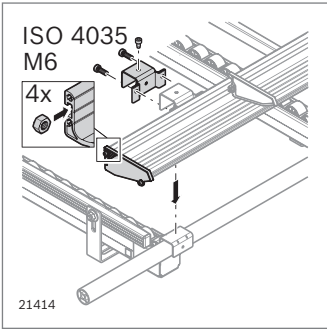
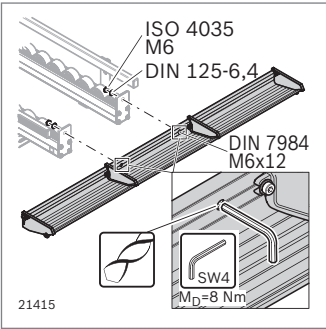
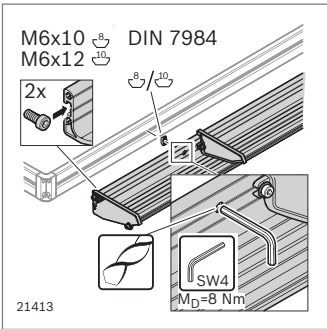
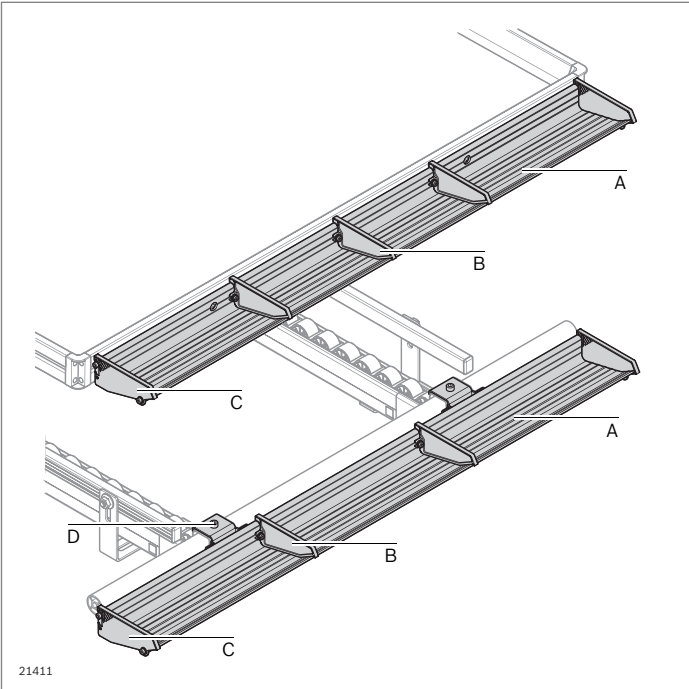


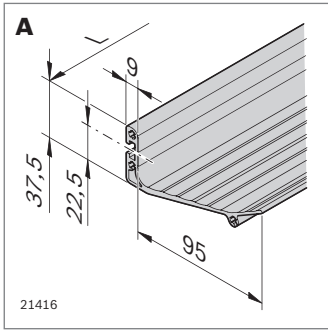


### Grab ledge



- ▶ Ergonomic, handy supply of small parts such as screws, nuts, and washers
- ▶ For fitting to material shelves or conveyor tracks to separate a mixed parts supply on an ergonomically designed picking surface
- ▶ Grab things quickly and safely
- ▶ Self-assembly elements for the individual assembly of grab ledges with different widths and partitions

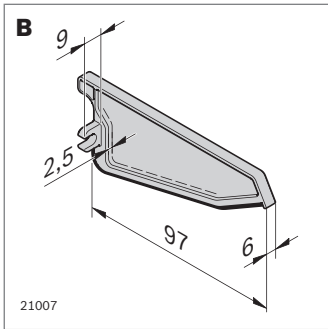




- ▶ Grab ledge with grooved surface (**A**) for ergonomic, fast, and secure picking

Material: Anodized aluminum, ESD-compatible surface (ESD); conduction resistance (R) <math>1 \times 10^8 \Omega</math>

	L (mm)		ESD	No.
<b>A</b> Grab ledge	855	2		<b>3 842 544 774</b>
	855	2		<b>3 842 546 747</b>

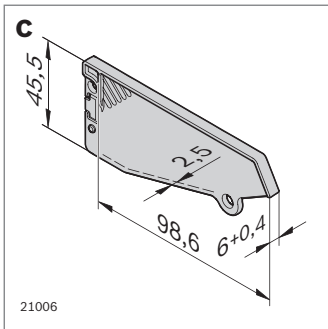


- ▶ Partition wall (**B**) for individual partition wall of the grab ledge
- ▶ Rubber lip for precise positioning on the grab ledge

Material: PA 66; black

Scope of delivery: Incl fastening material

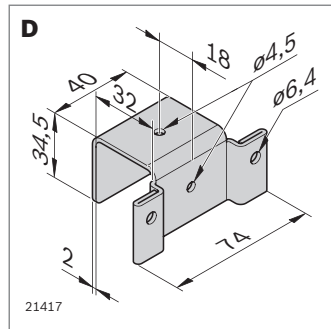
			ESD	No.
<b>B</b> Partition wall		10		<b>3 842 544 776</b>



- ▶ Stop plate (**C**) for end of grab ledge

Material: PA 66; black

Scope of delivery: Incl fastening material

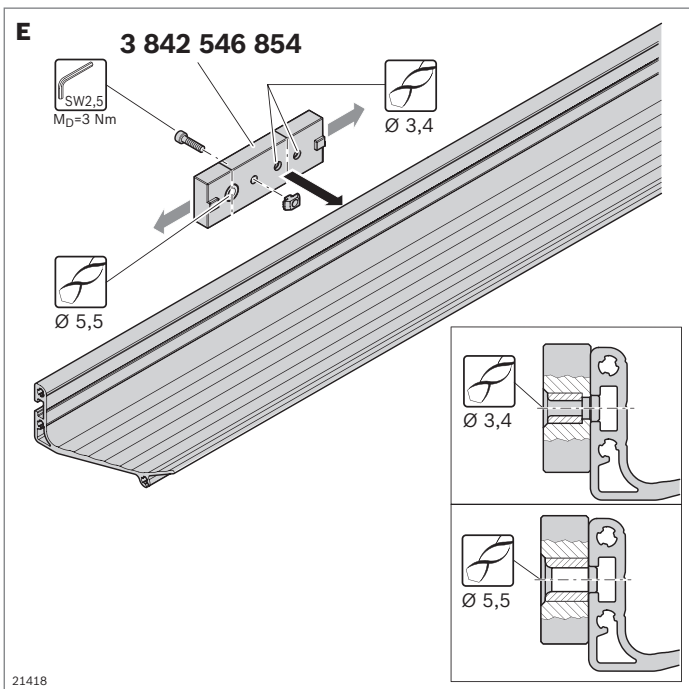


- ▶ Connection bracket (**D**) to fasten the grab ledge to a rail holder with stop (XLean, Lean, and EcoFlow conveyor sections)

Material: Sheet steel; zinc-plated; conductive; suitable for ESD applications

Scope of delivery: Incl fastening material

			ESD	No.
<b>C</b> Stop plate				<b>3 842 544 778</b>
<b>D</b> Connection bracket		2		<b>3 842 544 780</b>



- ▶ Drilling template (**E**) for mounting holes and through holes in the grab ledge

Scope of delivery: Incl fastening material

		No.
<b>E</b> Drilling template		<b>3 842 546 854</b>



3





## Dynamic sitting – ergonomic and functional

**Ergonomic and healthy sitting on the job greatly enhances employee performance.**

Regardless of whether you are working on a manual production line, in a cleanroom or at a final inspection workstation: Poor posture when carrying out your activities often leads to muscle, back, and joint problems, as well as circulation issues. This makes ergonomic seating all the

more important.

You can optimize the ergonomics of your workstations with functional swivel work chairs that are specifically adapted to the individual application. These chairs effectively cushion the physical strain caused by repetitive movements. They provide custom support for each employee to ensure a healthy posture throughout their shift. Increase your employees' well-being and productivity in the workstation and minimize sick days.



### Main features of Rexroth swivel work chairs

- ▶ The tapered backrest ensures optimal freedom of movement in the arm and shoulder area.
- ▶ The ergonomically designed seat provides optimum pelvic support. It has adjustable depth and tilt.
- ▶ All the adjustment options are easily accessible and can be made by simply pulling out the respective element.
- ▶ All swivel work chairs from Rexroth are equipped with a stable, five-arm star chair base. Low chairs are delivered with rollers and high models with sliders.
- ▶ The seat and backrest materials offer comfort, durability, and easy care.
- ▶ You also have the option to equip your chair with multi-adjusting armrests and a height-adjustable foot support or circular footrest.

4

## OVERVIEW SWIVEL WORK CHAIRS

**4-7** Swivel work chairs

**4-12** Accessories



## Healthy sitting – well-designed from the very start

**A work chair doesn't need to reveal at first glance how much sophisticated technology and medical expertise it contains. But it does need to perform the impressive feat of providing optimum seating comfort for every employee – whether slender or athletic, tall or short, light or heavy, young or old, fit or frail.**



### Seat height and depth adjustment

- ▶ Adjustment of seat height to the body height for good posture and circulation
- ▶ Setting an optimal seating position for a leg angle of 90 degrees
- ▶ Adjusting the chair to the leg length by changing the seat depth

### Backrest height and seat tilt adjustment

- ▶ Optimal support function provided by individual backrest adjustment for different user body types
- ▶ Adjustable seat angle – for optimum pelvic support
- ▶ Support of an active, upright seating and working posture

### Settings as individual as users

A variety of sophisticated details come together so that users can adjust the work chairs to meet their individual needs – from the foot support to the seat with multiple adjustment options, a backrest with lumbar support, and synchronous technology with weight regulation. MPS swivel work chairs from Rexroth promote ergonomic workstation seating, increase efficiency, and reduce illness-related absences.

### Dynamic seating – technology for the highest demands

Seated postures can only be healthy and ergonomic when coupled with movement. A good work chair supports these dynamics through innovative movement mechanisms. One key factor is switching between the front, center, and rear seating positions.

MPS swivel work chairs from Rexroth are equipped with a special synchronous technology that enables these posture changes, without any sacrifices in terms of the stabilizing backrest function. This provides optimal support and relief to the torso during all dynamic movement sequences while seated.

4



#### Lumbar support

- ▶ Backrest with integrated lumbar support to relieve the extensor muscles in the lumbar region



- ▶ Upright seating for a relaxed posture



#### Synchronous technology with continuous contact

- ▶ Permanent contact between back and backrest for efficient back muscle support
- ▶ Adaptation to the movement sequences involved in posture changes through effective synchronized mechanisms
- ▶ Synchronized movement of backrest and seat for optimum interplay of the hip and knee joints



#### Weight regulation

- ▶ Integrated weight regulation for individual adaptation to body weight
- ▶ Adjusting the resistance of the backrest via mechanical handles
- ▶ Effective cushioning of vertebral strain when switching between forward or reclining positions



## PRODUCT ADVANTAGES



- ▶ Seat height
- ▶ Backrest height
- ▶ Permanent contact backrest



- ▶ Seat height
- ▶ Seat angle



- ▶ Seat height
- ▶ Seat depth
- ▶ Seat angle
- ▶ Backrest height



- ▶ Permanent contact backrest
- ▶ Synchronous movement of backrest and seat
- ▶ Weight regulation for individual adaptation to body weight



- ▶ Height-adjustable foot support
- ▶ Seat height
- ▶ Backrest height



- ▶ Washable seat and backrest upholstery



- ▶ Conductive material according to DIN EN 61340-5-1, suitable for ESD-sensitive areas.



- ▶ The product complies with the safety rules and ergonomic requirements for swivel work chairs used in production as defined in DIN 68877

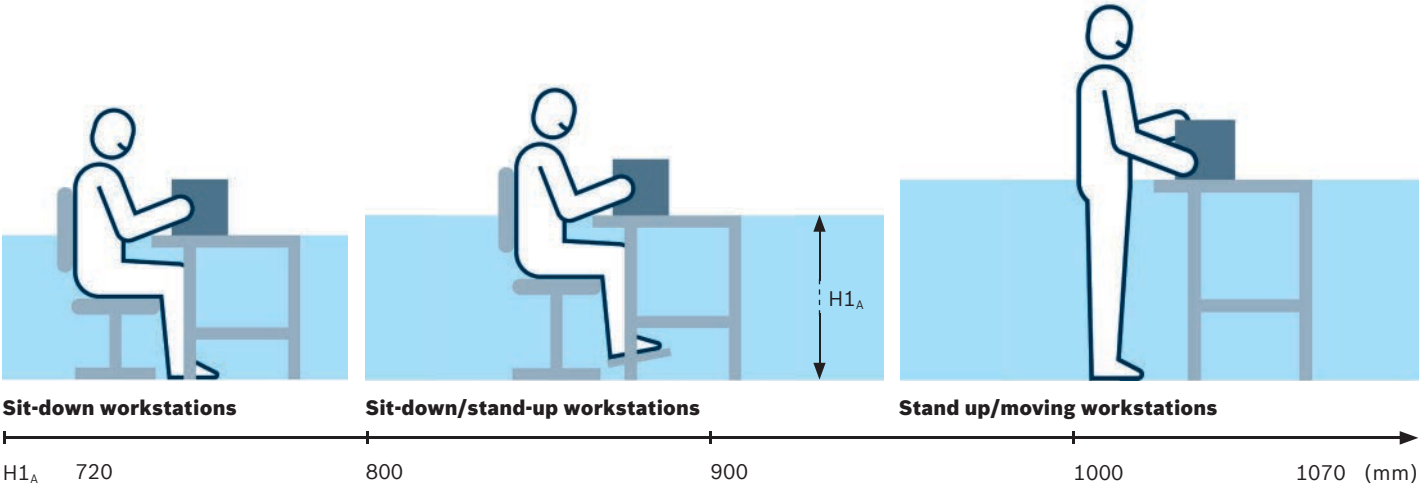


- ▶ Suitable for cleanrooms according to DIN EN ISO 14644-1



- ▶ This product complies with the requirements of the German Equipment and Product Safety Act (GPSG)

**ORDERING GUIDE**





### Basic



- ▶ Adjustment options
  - Seat height
  - Backrest height
- ▶ Properties
  - Max. permissible load 120 kg
  - Extremely durable
  - Easy-to-clean surface
- ▶ Scope of application
  - Production

Material: Seat and backrest: Wood; glued, 7 layers; clear varnish; star chair base: Plastic; castors: Soft PP; suitable for hard industrial flooring  
 Accessories: Circular footrest (page 4-12)

Basic	Version	Seat height (mm)	No.
Low	Castors	420 ... 570	<b>3 842 564 696</b>
High	Sliders	580 ... 830	<b>3 842 564 695</b>

According to DIN 68877, a work chair whose seat height is adjustable above 650 mm must be equipped with a circular footrest or foot support.



### Stool



- ▶ Adjustment options
  - Seat height
  - Seat angle
- ▶ Properties
  - Max. permissible load 120 kg
  - Durable
  - Easy-to-clean surface
- ▶ Scope of application
  - Production
  - At stand-up workstations to reduce muscle strain

Material: Seat: PU foam; black; rounded base: Steel

Stool	Version	Seat height (mm)	No.
	Rounded base	580 ... 860	<b>3 842 546 776</b>



Dynamic PU	Version	Seat height (mm)	No.
Low	Castors	460 ... 610	<b>3 842 546 762</b>
High	Sliders	580 ... 820	<b>3 842 546 763</b>

According to DIN 68877, a work chair whose seat height is adjustable above 650 mm must be equipped with a circular footrest or foot support.

## Dynamic PU



- ▶ Adjustment options
  - Seat height
  - Seat angle
  - Seat depth
  - Backrest height
  - Synchronous technology (synchronized backrest and seat movement)
  - Weight regulation
- ▶ Properties
  - Max. permissible load 120 kg
  - Durable
  - Easy-to-clean surface
  - Resistant to slightly acidic and caustic materials
- ▶ Scope of application
  - Mechanical production

Material: Seat and backrest: PU foam, black, full-surface weave with honeycomb effect; star chair base: Steel; castors: Soft PP, suitable for hard industrial flooring  
 Accessories: Foot support, circular footrest, armrest (page 4-12)



Dynamic textile	Version	Seat height (mm)	No.
Low	Castors	460 ... 610	<b>3 842 546 766</b>
High	Sliders	580 ... 820	<b>3 842 546 767</b>

According to DIN 68877, a work chair whose seat height is adjustable above 650 mm must be equipped with a circular footrest or foot support.

## Dynamic textile



- ▶ Adjustment options
  - Seat height
  - Seat angle
  - Seat depth
  - Backrest height
  - Synchronous technology (synchronized backrest and seat movement)
  - Weight regulation
- ▶ Properties
  - Max. permissible load 120 kg
  - Soft, durable textile surface
  - Comfort seating
- ▶ Scope of application
  - Low-contamination environments
  - Inspection stations

Material: Seat and backrest: Breathable material, black; star chair base: Steel; castors: Soft PP, suitable for hard industrial flooring

Accessories: Foot support, circular footrest, armrest (see page 4-12)



## Dynamic ESD



- ▶ Adjustment options
  - Seat height
  - Seat angle
  - Seat depth
  - Backrest height
  - Synchronous technology (synchronized backrest and seat movement)
  - Weight regulation
- ▶ Properties
  - Max. permissible load 120 kg
  - Highly conductive, breathable fabric
- ▶ Scope of application
  - Electrical and electronics production
  - Conduction resistance:  $10^6 \dots 10^8 \Omega$

Material: Seat and backrest: Breathable cover with woven stainless steel fibers, black; star chair base: Steel; castors: Soft PP, suitable for hard industrial flooring  
 Accessories: Foot support, circular footrest, armrest (page 4-12)

Dynamic ESD	Version	Seat height (mm)	ESD	No.
Low	Castors	460 ... 610		<b>3 842 546 768</b>
High	Sliders	580 ... 820		<b>3 842 546 769</b>

According to DIN 68877, a work chair whose seat height is adjustable above 650 mm must be equipped with a circular footrest or foot support.



Dynamic clean	Version	Seat height (mm)	No.
Low	Castors	510 ... 650	<b>3 842 527 161</b>
High	Sliders	650 ... 910	<b>3 842 527 162</b>

According to DIN 68877, a work chair whose seat height is adjustable above 650 mm must be equipped with a circular footrest or foot support.

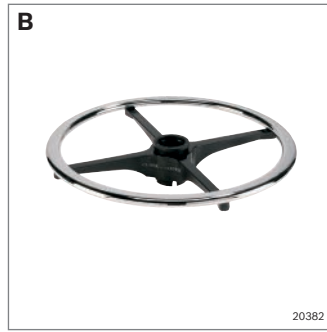
## Dynamic clean



- ▶ Adjustment options
  - Seat height
  - Seat angle
  - Backrest height
  - Synchronous technology (synchronized backrest and seat movement)
  - Weight regulation
- ▶ Properties
  - Max. permissible load 120 kg
  - Soft, non-slip and electrically conductive leather
- ▶ Scope of application
  - Cleanroom (cleanroom class ISO 4)
  - Electrical and electronics production
  - Conduction resistance:  $10^6 \Omega$

Material: Seat and backrest: electrically conductive leather, anthracite gray; star chair base: Aluminum

Scope of delivery for dynamic clean high: includes height-adjustable foot support



## Accessories



### Foot support (A)

- ▶ For dynamic PU, dynamic synthetic leather, dynamic textile and dynamic ESD swivel work chairs with a seat height above 650 mm. According to DIN 68877, work chairs with a seat height above 650 mm must be equipped with a foot support.
- ▶ Retractable
- ▶ Adjustable height
- ▶ Non-slip surface

### Circular footrest (B)

- ▶ For all swivel work chairs
- ▶ For secure mounting and a low-fatigue, ergonomic sitting posture
- ▶ Adjustable height

### Armrests (C)

- ▶ For dynamic PU, dynamic synthetic leather, dynamic textile and dynamic ESD
- ▶ Setting options: Height, width and projection angle

Scope of delivery: Incl fastening material

	ESD	No.
<b>A</b> Foot support		<b>3 842 546 772</b>
		<b>3 842 546 775</b>
<b>B</b> Circular footrest		<b>3 842 546 773</b>
<b>C</b> Armrests	Set	<b>3 842 557 271</b>
	Set	<b>3 842 557 272</b>



# Reduce your stocks with an efficient material supply system

## A well-structured and clearly organized material supply system generates transparency to help you reduce your stocks.

Rexroth's flow rack systems offer users in commerce, trades and industry a wide range of important advantages:

- ▶ Various conveyor tracks employing various conveyor media are able to transport all containers and weight classes safely and reliably.
- ▶ Simple conversion, attachment and expansion options future-proof your system.
- ▶ Ingenious details such as color-coded rollers for long-range inventory visualization (Kanban).
- ▶ The application of the FiFo principle reliably ensures that materials are used in the prescribed sequence.

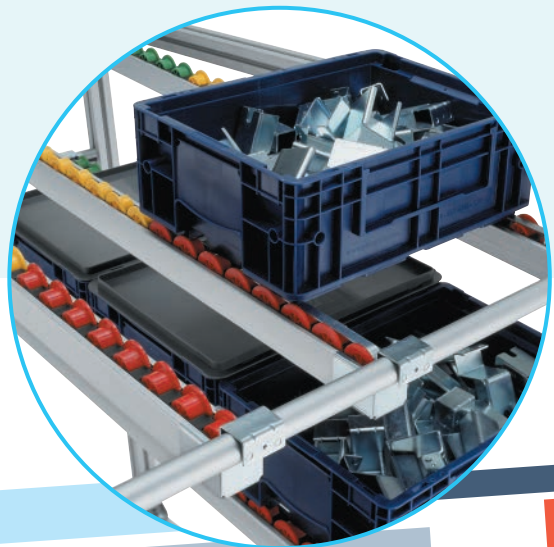
XLean is the favorably priced alternative. The Lean system gives you the advantages of high flexibility and numerous combination options – colored rollers to code your stock or to help distinguish between good and reject parts. Slide rails are available as the conveyor medium for certain applications, such as when you have a steeper gradient. For heavy loads or for moving blister packs or cardboard boxes, EcoFlow is your best choice.

The easiest way to order is to freely configure your flow rack system with your required dimensions and equipment. If you need even more flexibility, you can custom assemble your flow rack system from rack modules and individual components. All parts are designed to combine, so you can use the MTpro Layout Designer to put together your system any way you like.

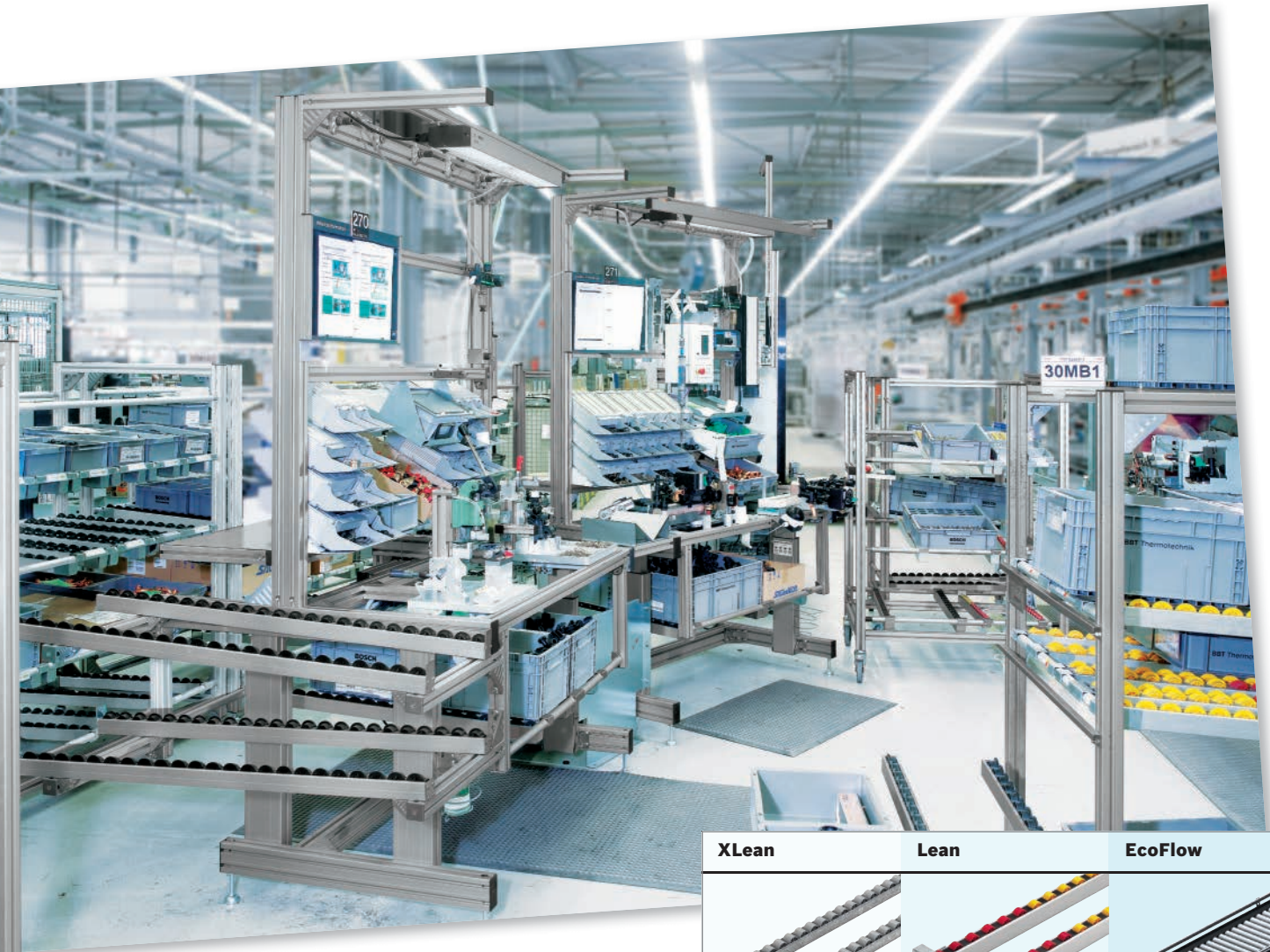
The flow rack system and components are available as an ESD-conductive design suitable for use in electrostatic protected area (EPAs).

### OVERVIEW













<b>5-4</b>	Flow rack systems	XLean Lean EcoFlow
<b>5-11</b>	Conveyor tracks	XLean Lean
<b>5-23</b>	Transport guide	
<b>5-25</b>	Cross ties	
<b>5-27</b>	Labeling clips	



# Flow rack systems



**When designing your flow rack system, it is essential to know which materials will be supplied in what quantity and in which containers. The number of parts and containers, their type, their dimensions and their weight all need to be taken into account.**

XLean	Lean	EcoFlow
		
 D28  D28SK	 D32  D32SK  GS  GS SK  RE45  RE45SK	
Cost-effective solution	Colored rollers for inventory visualization (Kanban)	Heavy loads, for blister packs and cardboard boxes

The load capacity of the flow racks depends on the selected parameters, the setup, the frame dimensions, and the shelves used and conveyor tracks used. The maximum load is 2000 kg. Detailed information on permissible loads is available in the "Technical data" chapter and in *MTpro*.

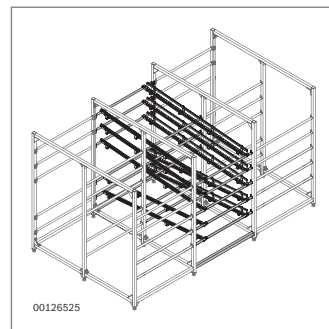
The selected conveyor media and lateral guides determine how well your containers travel through the system. The available conveyor media are known as XLean, Lean and EcoFlow. Besides the traditional form of material supply using material shelves, you can also combine rack components with workstations. The advantage of tracks over material shelves is that containers are supplied to users in a defined and precise manner. The containers cannot slip or get swapped because the tracks are adjusted to the particular container being transported.

The conveyor tracks can likewise be custom assembled from individual components or ordered as a complete unit.

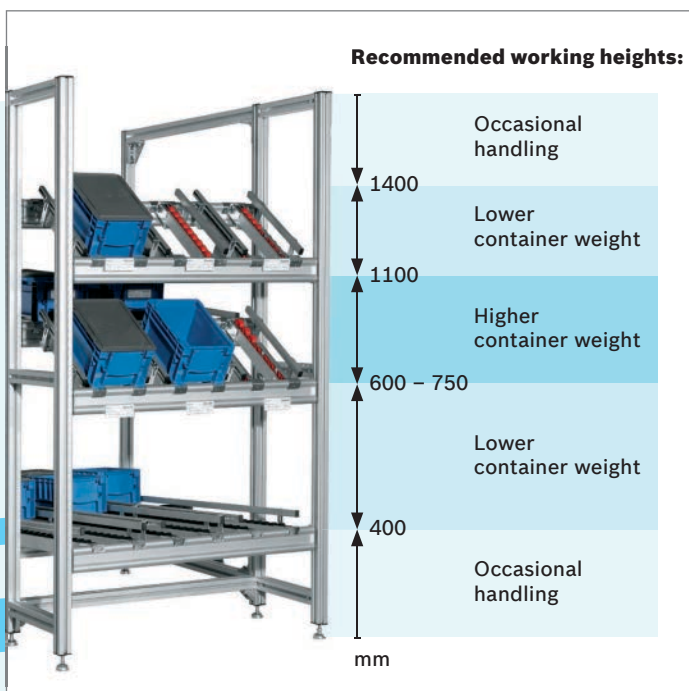
**Ergonomics**

The container weight, the type of activity involved and the overall strain placed on the worker during a shift are the key factors in ergonomically designing a flow rack system. During configuration you need to consider the different body sizes of your workers so that as many of them as possible can use the system effectively. You can use the national average as a guide.

The tracks should be horizontally and vertically spaced to leave a sufficient grab area. We recommend leaving 200 mm both above the container height and between the tracks.



◀ **The flow racks can stand alone or be set up in combination with one another. Combining flow racks allows you to save both space and money.**



◀ **All flow rack systems are ESD-conductive and suitable for use in ESD-sensitive areas. All the connection elements are designed such that the anodized coating on the aluminum profiles is pierced to ensure ESD conductivity throughout the system without the need for risky additional wiring.**

**MTpro**

Software for designing and planning flow rack systems. For detailed information, see pages 1-9/10 or [www.boschrexroth.com](http://www.boschrexroth.com)



00127214

**See technical data  
pages 13-12 ff.**

## XLean flow rack



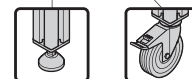
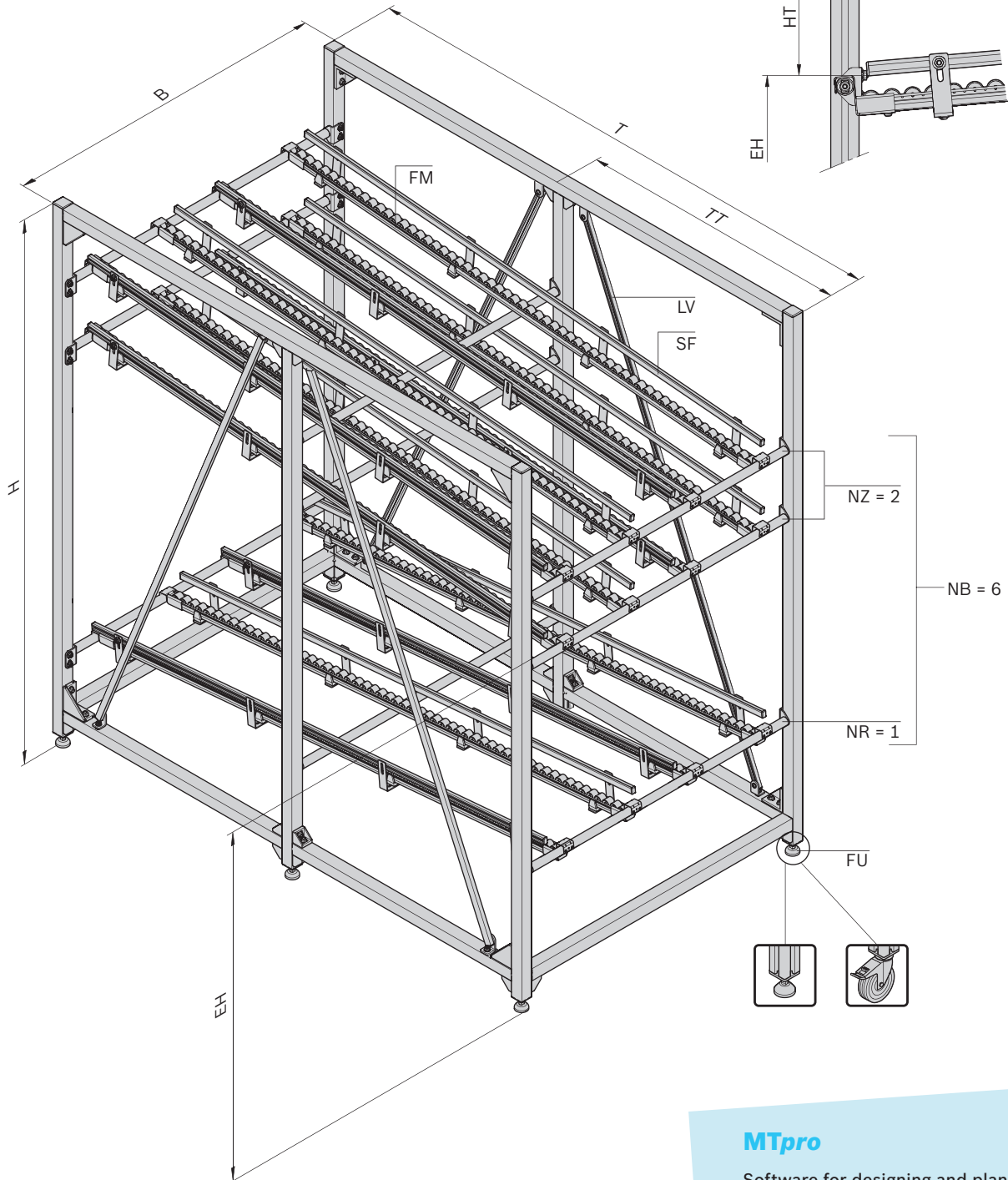
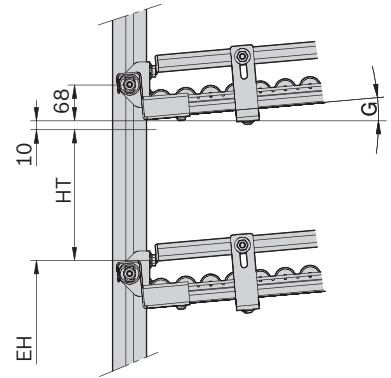
45 x 45 L



MTpro

- ▶ Material supply in the supermarket or directly at the workstation
- ▶ Cost-effective solution with conveyor tracks consisting of steel profiles and plastic rollers
- ▶ Available as ESD-conductive version
- ▶ Version: Fully assembled or as a kit for self-assembly
- ▶ Allows for the addition of any desired modules, including cross ties and conveyor tracks as well as individual components

XLean flow rack		3 842 998 249
<b>Type</b>	Number of side elements	0, 1, 2
<b>ESD</b>	Conductivity	Yes, no
<b>FU</b>	Foot type	Leveling foot, castor wheel
<b>A</b>	Version	Disassembled, assembled
<b>LV</b>	Load version (maximum load)	400 kg, 2000 kg
<b>B</b>	Flow rack system width	400 ... 1500 mm
<b>H</b>	Flow rack system height	600 ... 2000 mm
<b>T</b>	Flow rack system depth	400 ... 6000 mm
<b>EH</b>	Removal height of the lower supply level	263 ... 1800 mm
<b>HT</b>	Transportation height (clearance for container removal)	80 ... 1200 mm
<b>NZ</b>	Number of supply levels	1 ... 8
<b>NR</b>	Number of return levels	0 ... 7
<b>G</b>	Gradient	0 ... 10 % (recommended: 6 %)
<b>NB</b>	Number of conveyor tracks	0 ... 64
<b>FM</b>	Conveyor medium	Rollers with d = 28 mm with/without roller flange
<b>SF</b>	Lateral guide	With, without
<b>PT</b>	Cross tie type	Tubular cross tie, tubular cross tie with bracket, double tubular cross tie



00137573

**MTpro**

Software for designing and planning workstations. For detailed information, see pages 1-9/10 or [www.boschrexroth.com](http://www.boschrexroth.com)



00120898

**See technical data  
pages 13-12 ff.**

## Lean flow rack



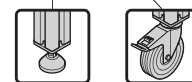
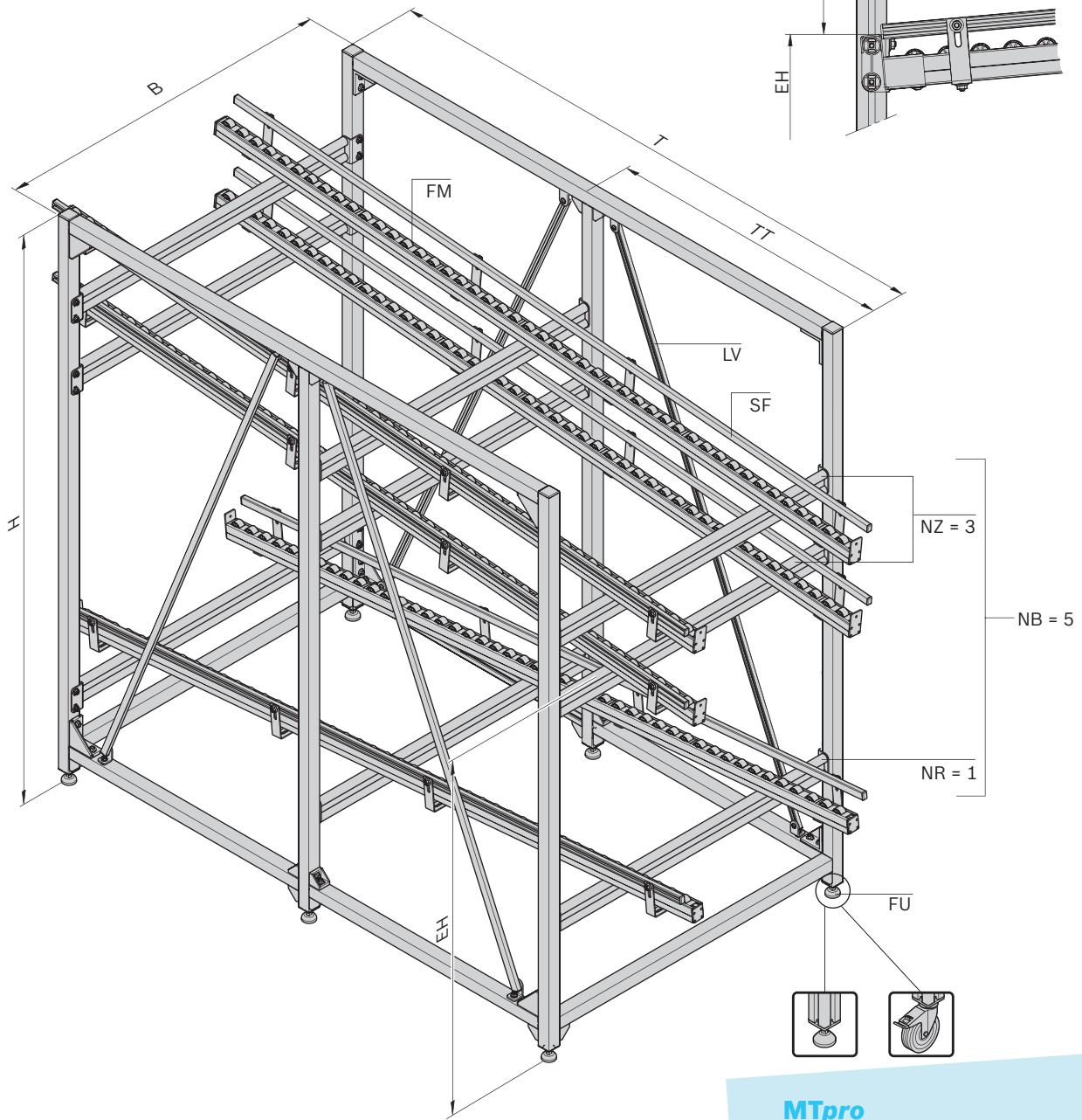
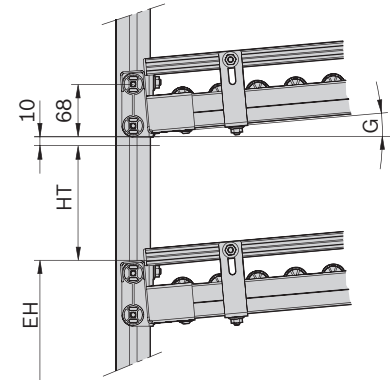
45 x 45 L



MTpro

- ▶ Material supply in the supermarket or directly at the workstation
- ▶ Selection of various conveyor media allows for maximum flexibility and diverse combination options: Rollers, roller elements and slide rails
- ▶ Colored rollers provide visual indicators to identify inventories or good/reject parts
- ▶ Available as ESD-conductive version
- ▶ Version: Fully assembled or as a kit
- ▶ Allows for the addition of any desired modules, including cross ties and conveyor tracks as well as individual components

Lean flow rack		3 842 998 332
<b>Type</b>	Number of side elements	0, 1, 2
<b>ESD</b>	Conductivity	Yes, no
<b>FU</b>	Foot type	Leveling foot, castor wheel
<b>A</b>	Version	Disassembled, assembled
<b>LV</b>	Load version (maximum load)	400 kg, 2000 kg
<b>B</b>	Flow rack system width	400 ... 1500 mm
<b>H</b>	Flow rack system height	600 ... 2000 mm
<b>T</b>	Flow rack system depth	400 ... 6000 mm
<b>TT</b>	Division of flow rack depth (max. distance between cross ties)	1000, 1500
<b>G</b>	Gradient	0 ... 10 % (recommended: 6 %)
<b>PT</b>	Cross tie type	Tubular cross tie, tubular cross tie with bracket, profile cross tie, double tubular cross tie
<b>UV</b>	Front conveyor track projection	0, 50 ... 1000 mm
<b>UH</b>	Rear conveyor track projection	0, 50 ... 1000 mm
<b>EH</b>	Removal height of the lower supply level	263 ... 1800 mm
<b>HT</b>	Transportation height (clearance for container removal)	100 ... 1200 mm
<b>NZ</b>	Number of supply levels	1 ... 8
<b>NR</b>	Number of return levels	0 ... 7
<b>NB</b>	Number of conveyor tracks	0 ... 64
<b>FM</b>	Conveyor medium	Rollers with d = 32 mm with/without roller flange, various spacings, slide rails with/without border, roller elements with/without border
<b>F</b>	Roller color	Black, red, yellow, green
<b>SF</b>	Lateral guide	With, without



**MTpro**

Software for designing and planning workstations. For detailed information, see pages 1-9/10 or [www.boschrexroth.com](http://www.boschrexroth.com)

00137583



00127572

**See technical data  
pages 13-12 ff.**

## EcoFlow flow rack



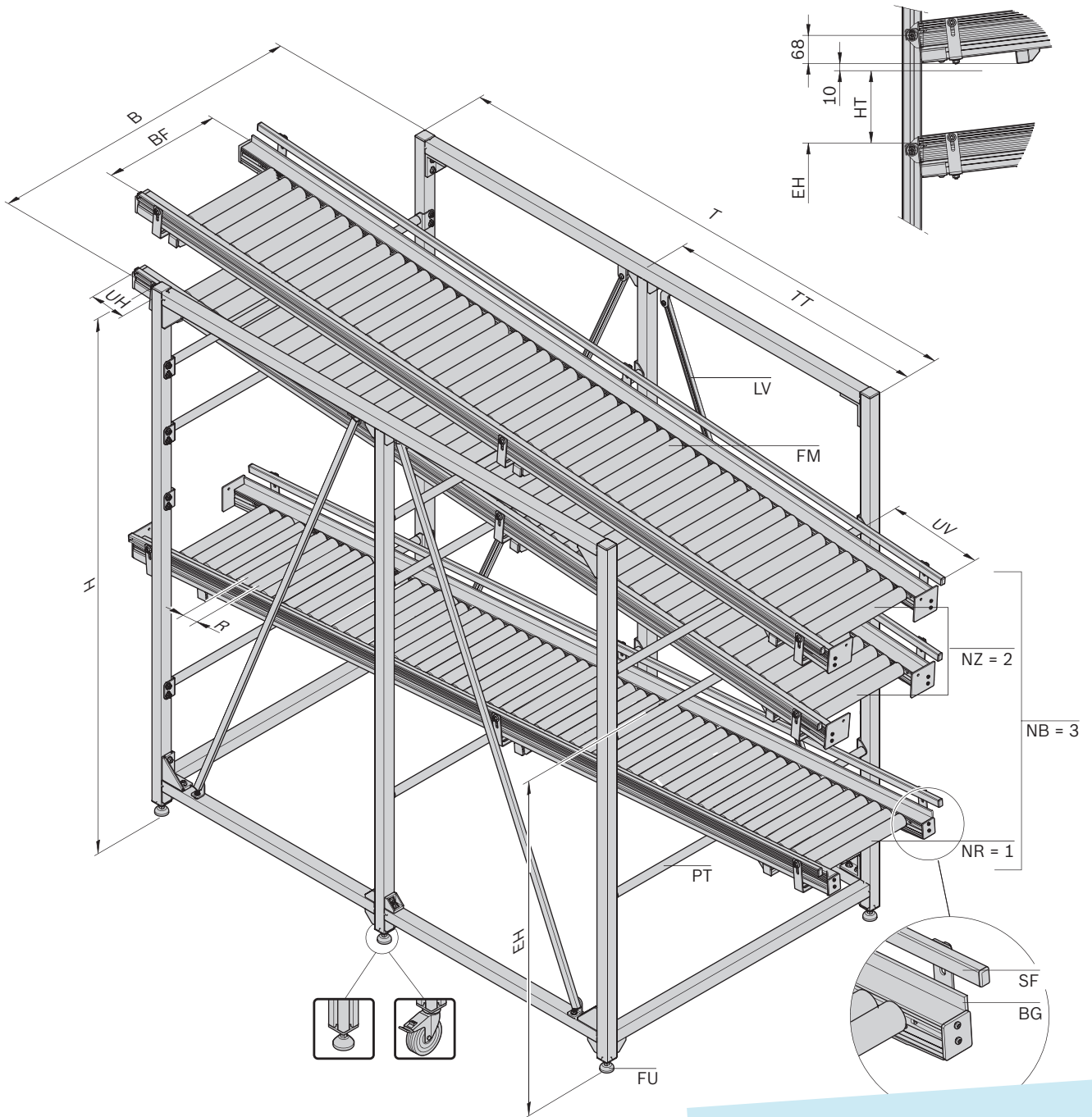
45 x 45 L



MTpro

- ▶ Material supply in the supermarket or directly at the workstation
- ▶ For heavy loads
- ▶ Full-width rollers for the transport and supply of blister packs or cardboard boxes
- ▶ Available as ESD-conductive version
- ▶ Version: Fully assembled or as a kit for self-assembly
- ▶ Allows for the addition of any desired modules, including cross ties and conveyor tracks as well as individual components

EcoFlow flow rack		3 842 998 322
<b>Type</b>	Number of side elements	0, 1, 2
<b>ESD</b>	Conductivity	Yes, no
<b>FU</b>	Foot type	Leveling foot, castor wheel
<b>A</b>	Version	Disassembled, assembled
<b>B</b>	Flow rack system width	400 ... 1000 mm
<b>H</b>	Flow rack system height	600 ... 2000 mm
<b>T</b>	Flow rack system depth	400 ... 6000 mm
<b>TT</b>	Division of flow rack depth (max. distance between cross ties)	1000, 1500
<b>G</b>	Gradient	0 ... 10 % (recommended: 6 %)
<b>PT</b>	Cross tie type	Tubular cross tie, tubular cross tie with bracket, profile cross tie, double tubular cross tie
<b>UV</b>	Front conveyor track projection	0, 50 ... 1000 mm
<b>UH</b>	Rear conveyor track projection	0, 50 ... 1000 mm
<b>EH</b>	Removal height of the lower supply level	263 ... 1800 mm
<b>HT</b>	Transportation height (clearance for container removal)	100 ... 1200 mm
<b>NZ</b>	Number of supply levels	1 ... 8
<b>NR</b>	Number of return levels	0 ... 7
<b>NB</b>	Number of conveyor tracks	0 ... 20
<b>FM</b>	Conveyor medium	Rollers in plastic, steel, stainless steel
<b>SF</b>	Lateral guide	With, without
<b>R</b>	Roller distance	50, 100 mm
<b>BG</b>	Slide rail border	Inside, outside
<b>BF</b>	Conveyor track width	200 ... 892 mm



00137584

**MTpro**

Software for designing and planning workstations. For detailed information, see pages 1-9/10 or [www.boschrexroth.com](http://www.boschrexroth.com)



### XLean conveyor tracks

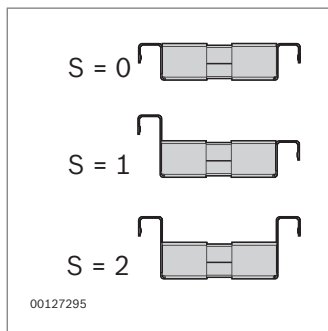
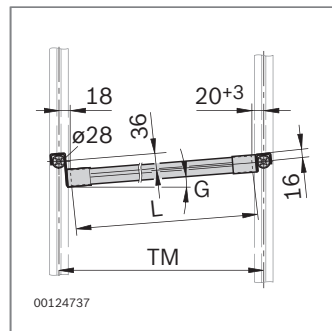
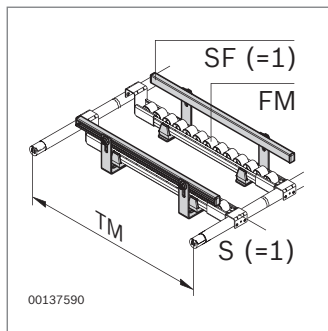


- ▶ Conveyor track made of steel profiles with plastic rollers and optional roller flange
- ▶ Rail holders for mounting to tubular cross tie
- ▶ Recommended gradient:  $G = 6\%$
- ▶ Available as ESD-conductive version

Scope of delivery: Conveyor track consisting of two conveyor sections (right/left) with rail holders



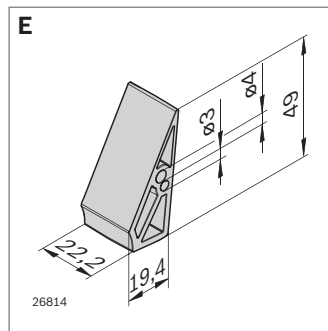
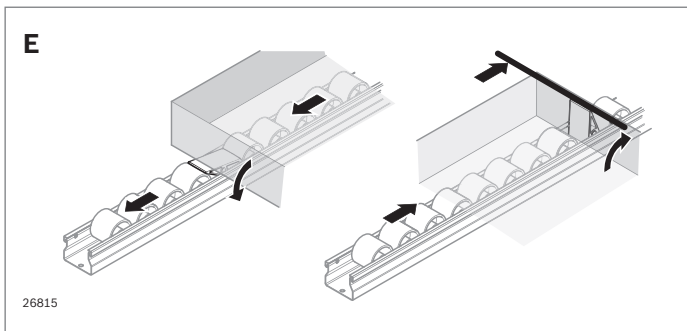
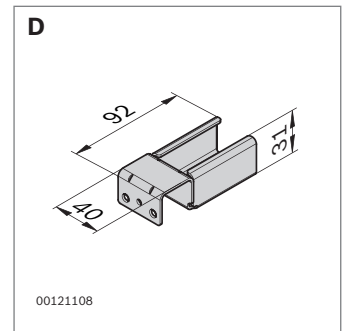
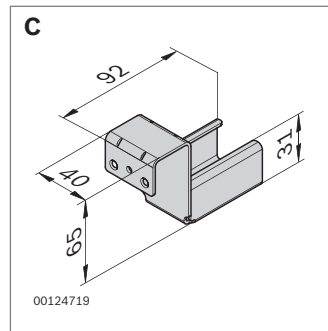
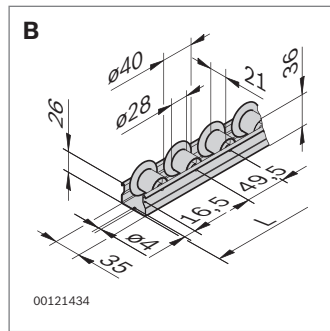
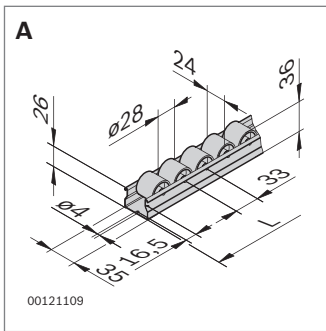
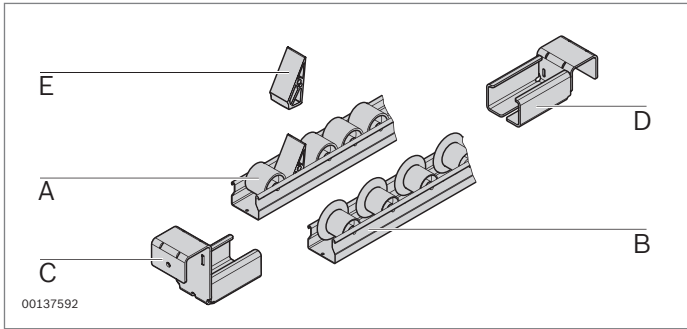
For workstation design and planning, we recommend **MTpro**! See pages 1-9/10 for more information.



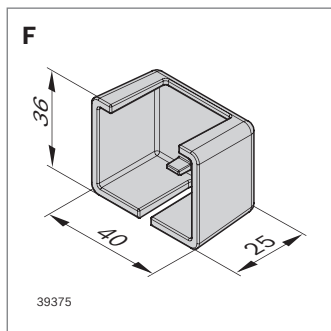
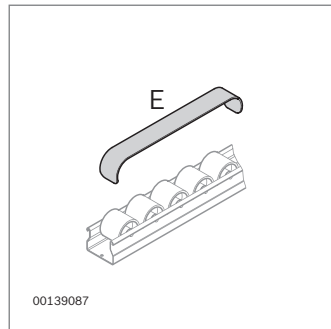
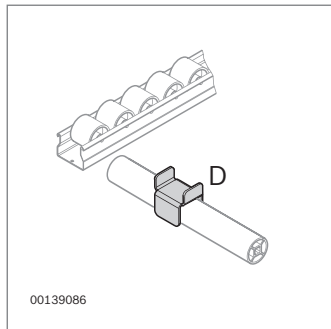
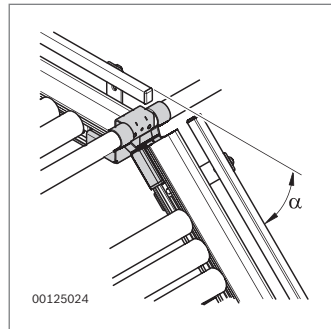
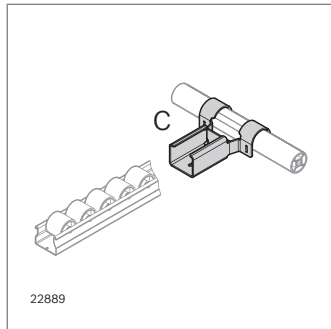
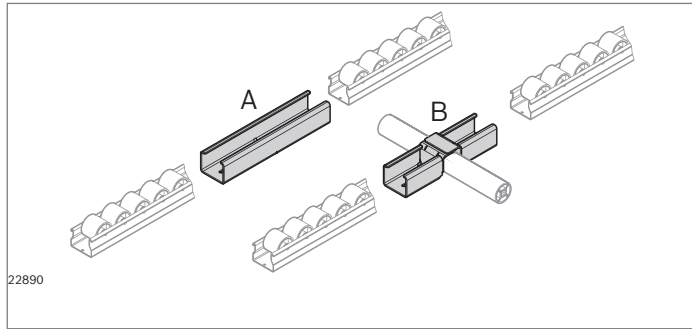
TM (mm)	G (%)	L (mm)
1000	0	962.0
1000	6	961.7
1000	10	963.5

XLean conveyor tracks		3 842 998 196
<b>ESD</b>	Conductivity	Yes, no
<b>TM</b>	Horizontal distance between tubular cross ties	355 ... 4500 mm
<b>G</b>	Gradient	0 ... 10 % (recommended: 6 %)
<b>FM</b>	Conveyor medium	Rollers with $d = 28$ mm with/without roller flange
<b>S</b>	Rail holder design	With/without stop
<b>SF</b>	Lateral guide	With, without

### XLean conveyor tracks – components



	Length (mm)		ESD	No.
A D28 roller section	100 ... 4500			3 842 993 321/L
	4500	50		3 842 537 776
	100 ... 4500			3 842 993 431/L
	4500	50		3 842 537 778
B D28SK roller section	100 ... 4500			3 842 993 322/L
	4500	50		3 842 537 777
	100 ... 4500			3 842 993 432/L
	4500	50		3 842 537 779
C Rail holder with stop	20			3 842 538 372
D Rail holder without stop	20			3 842 537 687
E XLean/Lean stopper	10			3 842 552 151



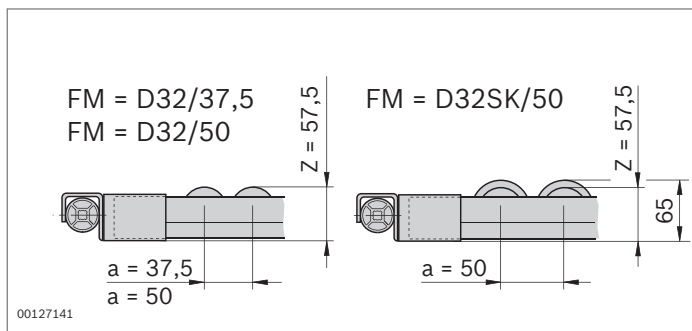
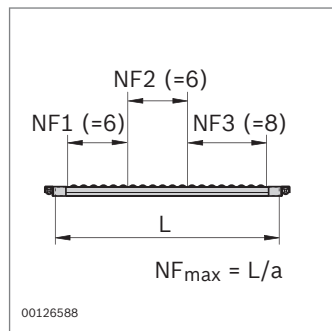
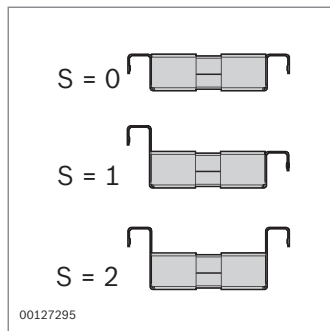
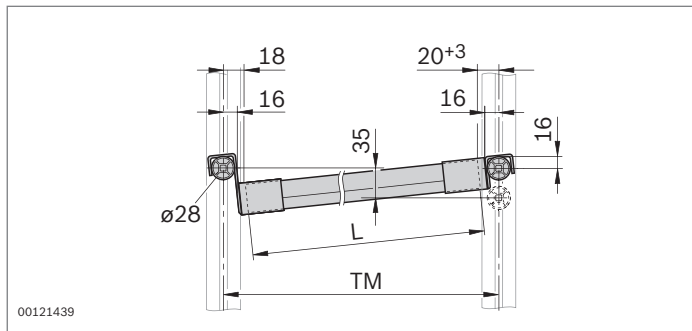
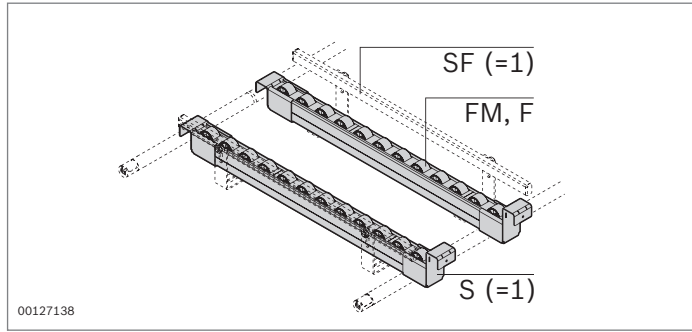
## XLean – accessories

- ▶ **Section link (A)** for connecting two XLean roller sections together
- ▶ **Bridge (B)** for connecting two XLean roller sections and simultaneously fixing them to the tubular cross tie. This increases the rigidity of the system
- ▶ **Flexible bridge (C)** for easy material supply in the flow rack system. The container is stopped by a rail holder with stop and is moved manually to the inclined position.  
Maximum inclination ( $a_{\max}$ ) compared to horizontal:
  - With tubular cross tie:  $a_{\max} = 40^\circ$
  - With double tubular cross tie:  $a_{\max} = 30^\circ$
- ▶ **Mount (D)** to secure the roller section to an additional tubular cross tie. The additional tubular cross tie increases the stability of the system
- ▶ **Brake (E)** for bringing containers to a gentle stop
- ▶ **Cover cap (F)** for covering open ends of XLean roller sections

Material: PP (conductive), black

	ESD	No.
<b>A</b> Section link	20	<b>3 842 536 722</b>
<b>B</b> Bridge	20	<b>3 842 536 724</b>
<b>C</b> Flexible bridge	20	<b>3 842 537 911</b>
<b>D</b> Mount	20	<b>3 842 537 657</b>
<b>E</b> Brake	20	<b>3 842 532 871</b>
<b>F</b> Cover cap	20	<b>3 842 562 077</b>





## Lean conveyor tracks with rail holder



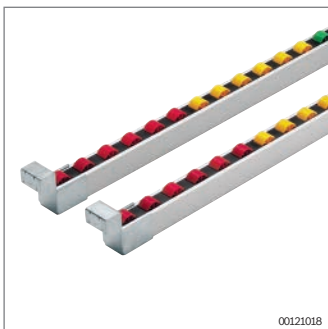
- ▶ Aluminum U-profile conveyor track
- ▶ Conveyor media to meet all requirements:
  - Rollers with or without roller flange. Four colors to visually identify inventories (Kanban) or to differentiate between good and reject parts
  - Roller elements with and without roller flange (RE45, RE45SK)
  - Slide rails with or without integrated lateral guide (GS, GSSK)
- ▶ Rail holders for suspending to tubular cross tie
- ▶ Available as ESD-conductive version (U-profile: Bare aluminum)

Scope of delivery: Conveyor track consisting of two conveyor sections (right/left) with rail holders

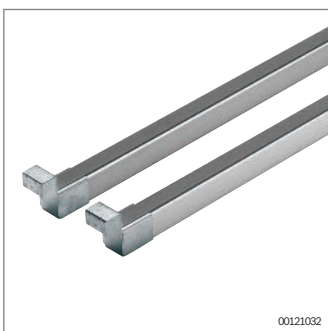
**MTpro** For workstation design and planning, we recommend **MTpro**! See pages 1-9/10 for more information.



<b>Conveyor track with rail holder, single-color rollers</b>		<b>3 842 998 381</b>
<b>ESD</b>	Conductivity	Yes, no
<b>TM</b>	Horizontal distance between tubular cross ties	355 ... 6000 mm
<b>G</b>	Gradient	0 ... 10 % (recommended: 6 %)
<b>FM</b>	Conveyor medium	Rollers with d = 32 mm with/without roller flange, various spacings
<b>F</b>	Roller color	Black, red, yellow, green
<b>S</b>	Rail holder design	With/without stop
<b>SF</b>	Lateral guide	With, without



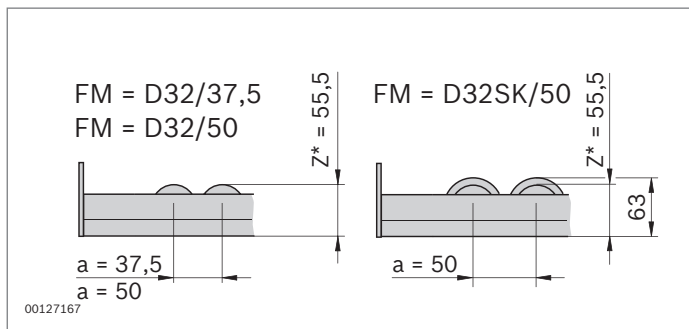
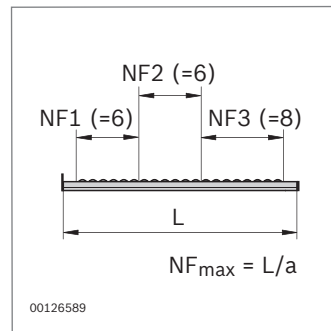
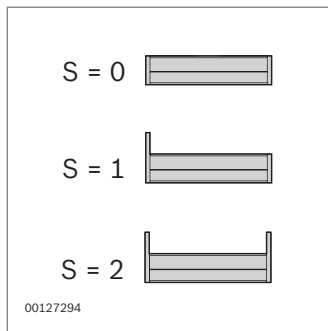
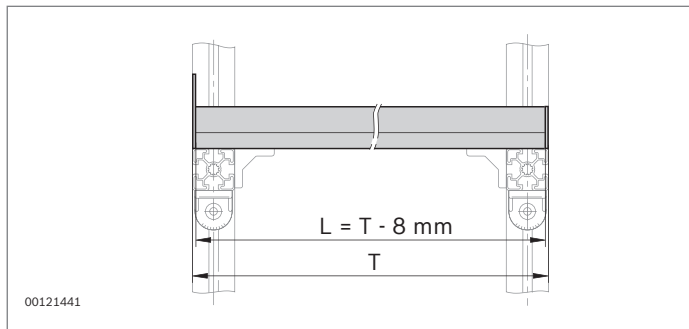
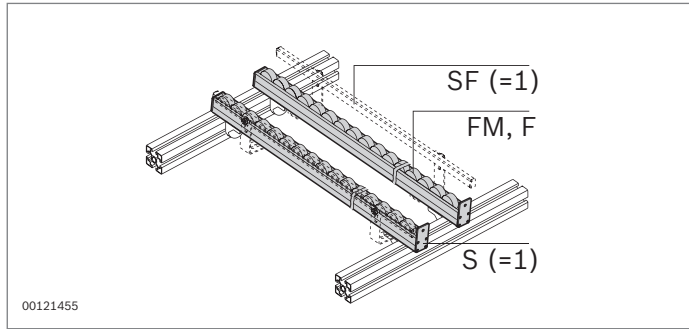
<b>Conveyor track with rail holder, multi-color rollers</b>		<b>3 842 998 382</b>
<b>ESD</b>	Conductivity	Yes, no
<b>TM</b>	Horizontal distance between tubular cross ties	355 ... 6000 mm
<b>G</b>	Gradient	0 ... 10 % (recommended: 6 %)
<b>FM</b>	Conveyor medium	Rollers with d = 32 mm with/without roller flange, various spacings
<b>F1</b>	Roller color	Black, red, yellow, green
<b>NF1</b>	Number of rollers in color 1	Max. 160
<b>F2</b>	Roller color	Black, red, yellow, green
<b>NF2</b>	Number of rollers in color 2	Max. 160
<b>F3</b>	Roller color	Black, red, yellow, green
<b>NF3</b>	Number of rollers in color 3	Max. 160
<b>S</b>	Rail holder design	With/without stop
<b>SF</b>	Lateral guide	With, without



<b>Conveyor track with rail holder, slide rails</b>		<b>3 842 998 387</b>
<b>ESD</b>	Conductivity	Yes, no
<b>TM</b>	Horizontal distance between tubular cross ties	355 ... 6000 mm
<b>G</b>	Gradient	0 ... 10 % (recommended: 6 %)
<b>FM</b>	Conveyor medium	Slide rails with/without border
<b>S</b>	Rail holder design	With/without stop
<b>SF</b>	Lateral guide	With, without



<b>Conveyor track with rail holder, roller elements</b>		<b>3 842 998 385</b>
<b>ESD</b>	Conductivity	Yes, no
<b>TM</b>	Horizontal distance between tubular cross ties	355 ... 6000 mm
<b>G</b>	Gradient	0 ... 10 % (recommended: 6 %)
<b>FM</b>	Conveyor medium	Roller elements with/without border
<b>S</b>	Rail holder design	With/without stop
<b>SF</b>	Lateral guide	With, without

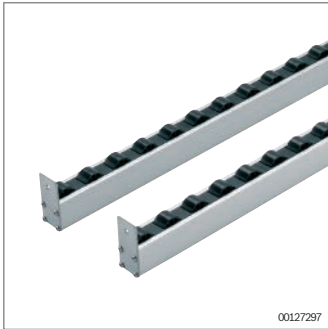


### Lean conveyor tracks with stop plates

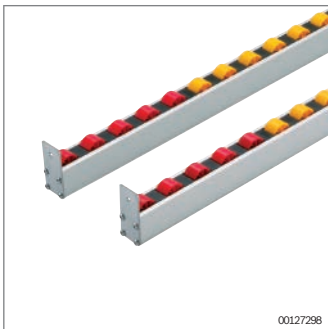


- ▶ Aluminum U-profile conveyor track
- ▶ Conveyor media to meet all requirements:
  - Rollers with or without roller flange. Four colors to visually identify inventories (Kanban) or to differentiate between good and reject parts.
  - Roller elements with and without roller flange (RE45, RE45SK)
  - Slide rails with or without integrated lateral guide (GS, GSSK)
- ▶ Applications include the manual linking of workstations
- ▶ Available as ESD-conductive version (U-profile: Bare aluminum)

Scope of delivery: Conveyor track consisting of two conveyor sections (right/left) with stop plates



<b>Conveyor track with stop plate, single-color rollers</b>		<b>3 842 998 383</b>
<b>ESD</b>	Conductivity	Yes, no
<b>L</b>	Conveyor track length	355 ... 6000 mm
<b>FM</b>	Conveyor medium	Rollers with d = 32 mm with/without roller flange, various spacings
<b>F</b>	Roller color	Black, red, yellow, green
<b>S</b>	Stop plate version	With/without stop
<b>SF</b>	Lateral guide	With, without



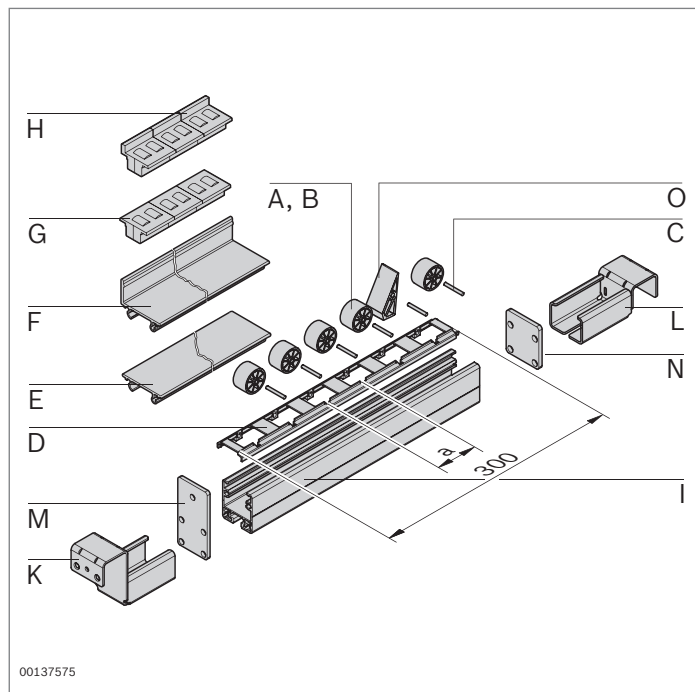
<b>Conveyor track with stop plate, multi-color rollers</b>		<b>3 842 998 384</b>
<b>ESD</b>	Conductivity	Yes, no
<b>L</b>	Conveyor track length	355 ... 6000 mm
<b>FM</b>	Conveyor medium	Rollers with d = 32 mm with/without roller flange, various spacings
<b>F1</b>	Roller color	Black, red, yellow, green
<b>NF1</b>	Number of rollers in color 1	Max. 160
<b>F1</b>	Roller color	Black, red, yellow, green
<b>NF2</b>	Number of rollers in color 2	Max. 160
<b>F1</b>	Roller color	Black, red, yellow, green
<b>NF3</b>	Number of rollers in color 3	Max. 160
<b>S</b>	Stop plate version	With/without stop
<b>SF</b>	Lateral guide	With, without



<b>Conveyor track with stop plate, slide rails</b>		<b>3 842 998 388</b>
<b>ESD</b>	Conductivity	Yes, no
<b>L</b>	Conveyor track length	355 ... 6000 mm
<b>FM</b>	Conveyor medium	Slide rails with/without border
<b>S</b>	Stop plate version	With/without stop
<b>SF</b>	Lateral guide	With, without



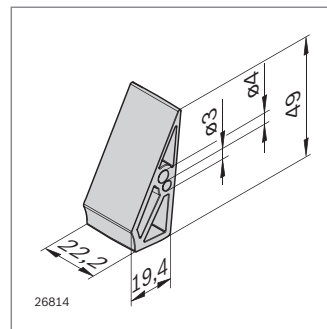
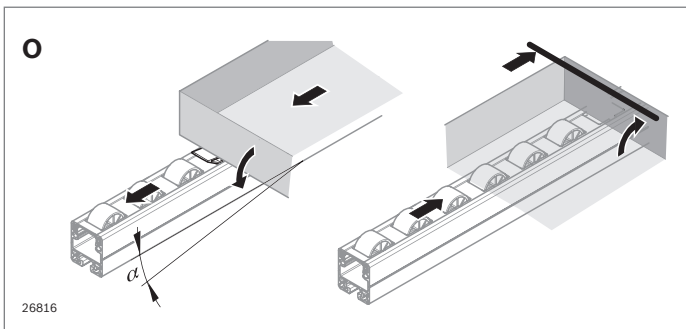
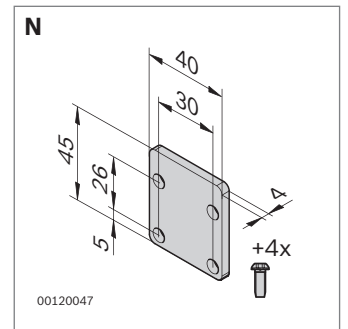
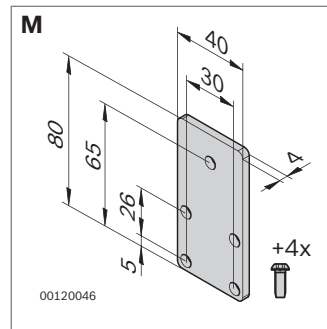
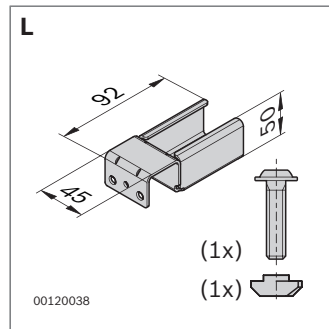
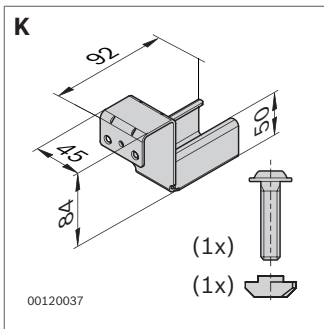
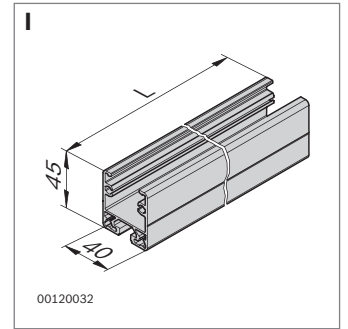
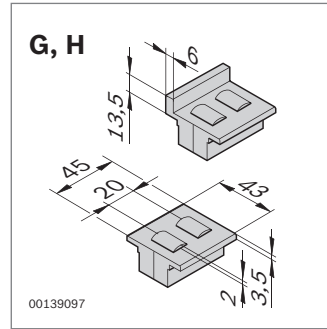
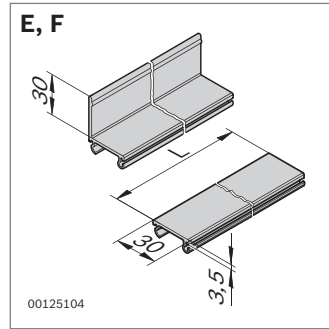
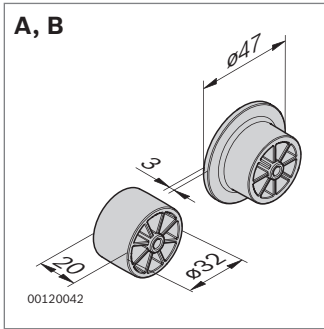
<b>Conveyor track with stop plate, roller elements</b>		<b>3 842 998 386</b>
<b>ESD</b>	Conductivity	Yes, no
<b>L</b>	Conveyor track length	355 ... 6000 mm
<b>FM</b>	Conveyor medium	Roller elements with/without border
<b>S</b>	Stop plate version	With/without stop
<b>SF</b>	Lateral guide	With, without












### Lean conveyor tracks – components



	a (mm)	ESD	No.
<b>A</b> D32 roller, black	100		<b>3 842 532 865</b>
	100	⚠	<b>3 842 537 961</b>
	D32 roller, red		
	100		<b>3 842 532 866</b>
	100	⚠	<b>3 842 537 960</b>
	D32 roller, yellow		
	100		<b>3 842 532 870</b>
D32 roller, green			
	100	⚠	<b>3 842 537 959</b>
	100		<b>3 842 532 752</b>
	100	⚠	<b>3 842 537 958</b>
<b>B</b> D32SK roller, black	100		<b>3 842 532 867</b>
	100	⚠	<b>3 842 537 965</b>
	D32SK roller, red		
	100		<b>3 842 532 883</b>
	100	⚠	<b>3 842 537 964</b>
	D32SK roller, yellow		
	100		<b>3 842 532 884</b>
D32SK roller, green			
	100	⚠	<b>3 842 537 963</b>
	100		<b>3 842 532 880</b>
	100	⚠	<b>3 842 537 962</b>
<b>C</b> Steel axle	100	⚠	<b>3 842 532 862</b>
<b>D</b> D32/37.5 roller carrier	37.5	20	<b>3 842 537 944</b>
		20	⚠ <b>3 842 537 945</b>
D32/50 roller carrier	50	20	<b>3 842 532 887</b>
		20	⚠ <b>3 842 538 094</b>
D32SK/50 roller carrier	50	20	<b>3 842 532 886</b>
		20	⚠ <b>3 842 537 947</b>

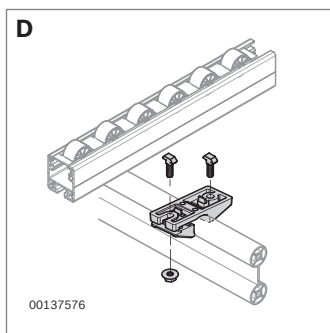
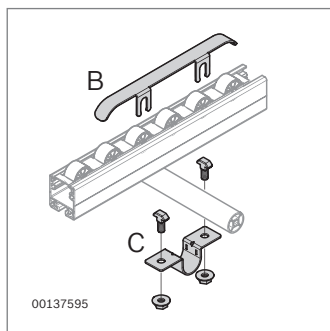
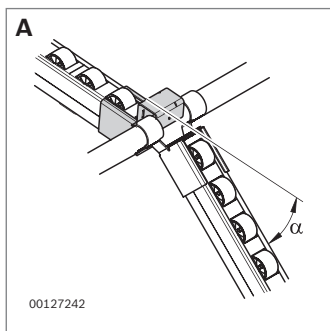



	L (mm)			ESD	No.
<b>E</b> Slide rail	3000	20			<b>3 842 535 124</b>
	3000	20			<b>3 842 537 803</b>
<b>F</b> Slide rail, lateral guide	3000	20			<b>3 842 537 806</b>
	3000	20			<b>3 842 537 807</b>
<b>G</b> RE45 roller elements	45	100			<b>3 842 554 746</b>
	45	100			<b>3 842 538 064</b>
<b>H</b> RE45SK roller elements	45	100			<b>3 842 554 748</b>
	45	100			<b>3 842 538 065</b>
<b>I</b> U-profile	30 ... 6070				<b>3 842 993 316/L</b>
	30 ... 6070				<b>3 842 995 027/L</b>
	6070				<b>3 842 564 223</b>
	6070	20			<b>3 842 535 115</b>
	6070	20			<b>3 842 541 814</b>
<b>K</b> Rail holder with stop		20			<b>3 842 537 660</b>
<b>L</b> Rail holder without stop		20			<b>3 842 537 661</b>
<b>M</b> 40x80 stop plate with stop		20			<b>3 842 535 121</b>
<b>N</b> 40x45 stop plate without stop		20			<b>3 842 535 122</b>
<b>O</b> XLean/Lean stopper		10			<b>3 842 552 151</b>

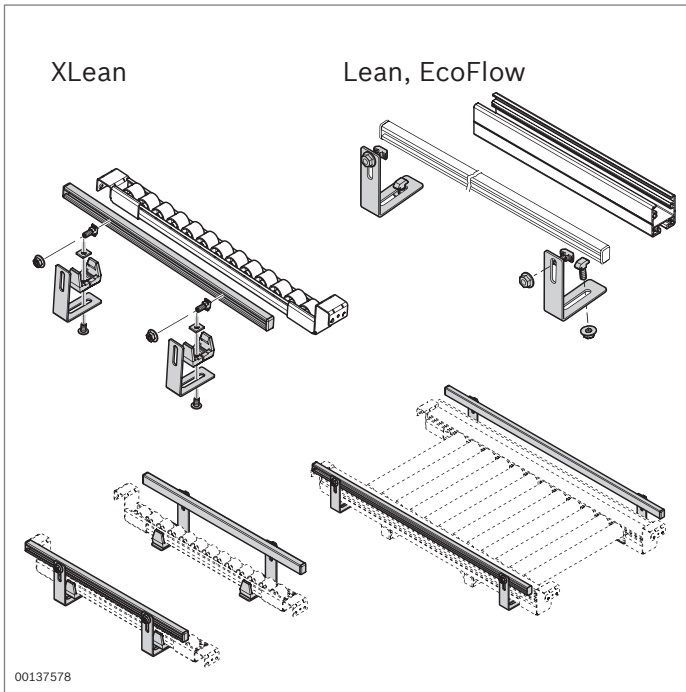


### Lean - accessories

- ▶ **Flexible bridge (A)** for the ergonomic supply of containers in the flow rack system or at the workstation. The container is stopped at the flexible bridge and then manually moved to the ergonomic removal position. Maximum inclination ( $a_{\max}$ ) compared to horizontal:
  - With tubular cross tie:  $a_{\max} = 40^\circ$
  - With double tubular cross tie:  $a_{\max} = 30^\circ$
- ▶ **Brake (B)** for bringing containers to a gentle stop
- ▶ **Tube clamp (C)** for fastening conveyor tracks onto the tubular cross tie. Increased stability
- ▶ **Holder for double tubular cross tie (D)** for connecting conveyor track and double tubular cross tie. Increased stability
- ▶ Suitable for ESD applications

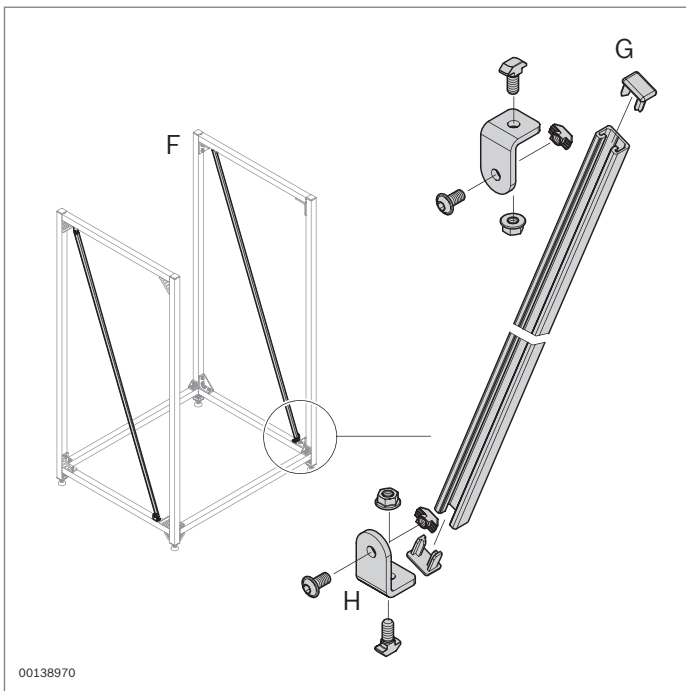


		No.
<b>A</b>	Flexible bridge	20 <b>3 842 537 951</b>
<b>B</b>	D32/37.5 brake	20 <b>3 842 537 948</b>
	D32/50, D32SK/50 brake	20 <b>3 842 532 881</b>
<b>C</b>	D28 tube clamp	20 <b>3 842 535 364</b>
<b>D</b>	Holder for double tubular cross tie	20 <b>3 842 537 720</b>



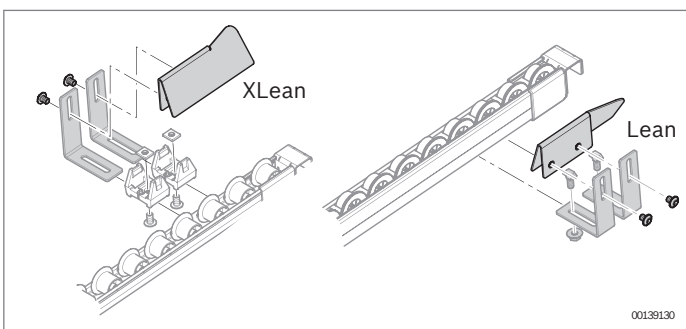
### Lateral guide application

- ▶ For retrofitting a lateral guide to the XLean, Lean and EcoFlow conveyor tracks
- ▶ For self-assembly elements, see "Components" section (page 12-9)



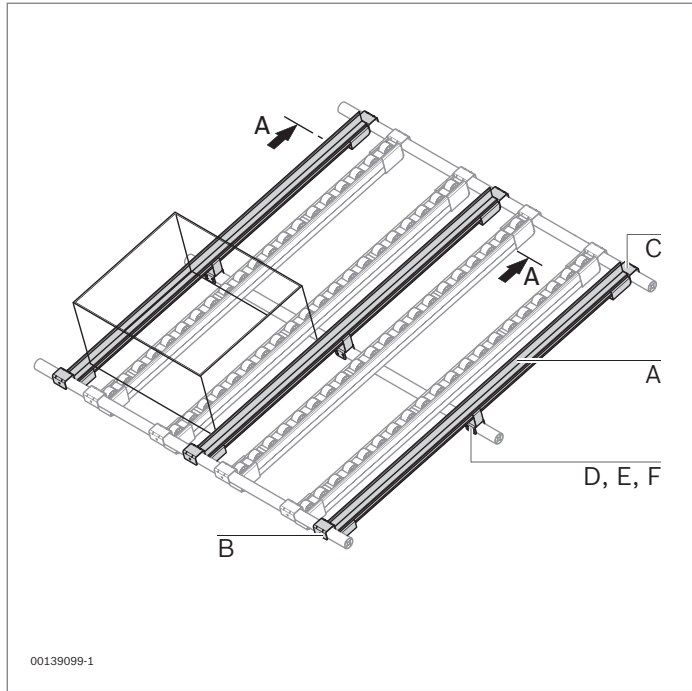
### Reinforcement application

- ▶ For constructing flow racks with increased stability
- ▶ Rack loads up to 2000 kg
- ▶ For self-assembly elements, see "Components" section (page 12-9)



### Insertion aid application

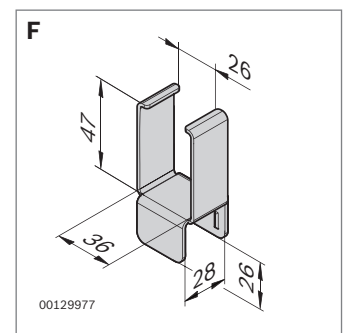
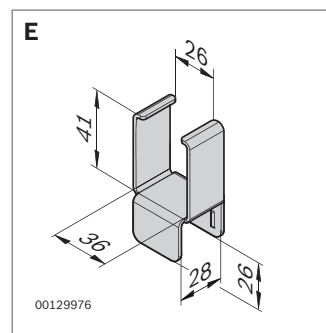
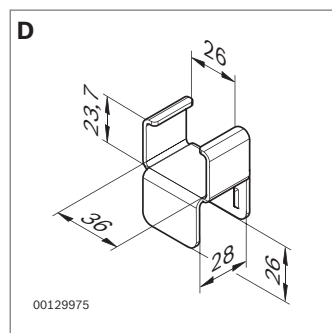
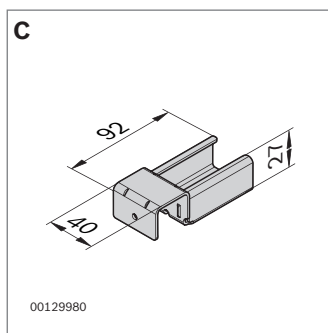
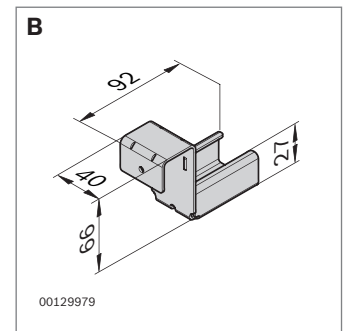
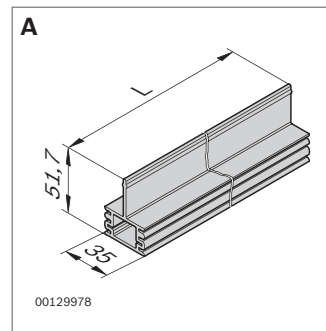
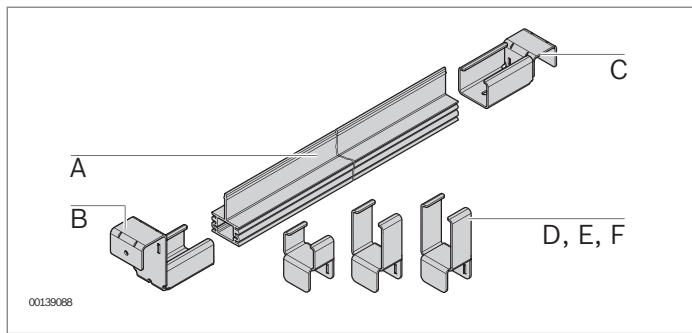
- ▶ Helps logisticians to insert material containers onto a conveyor track
- ▶ Quick and easy insertion
- ▶ For self-assembly elements, see "Components" section (page 12-9)



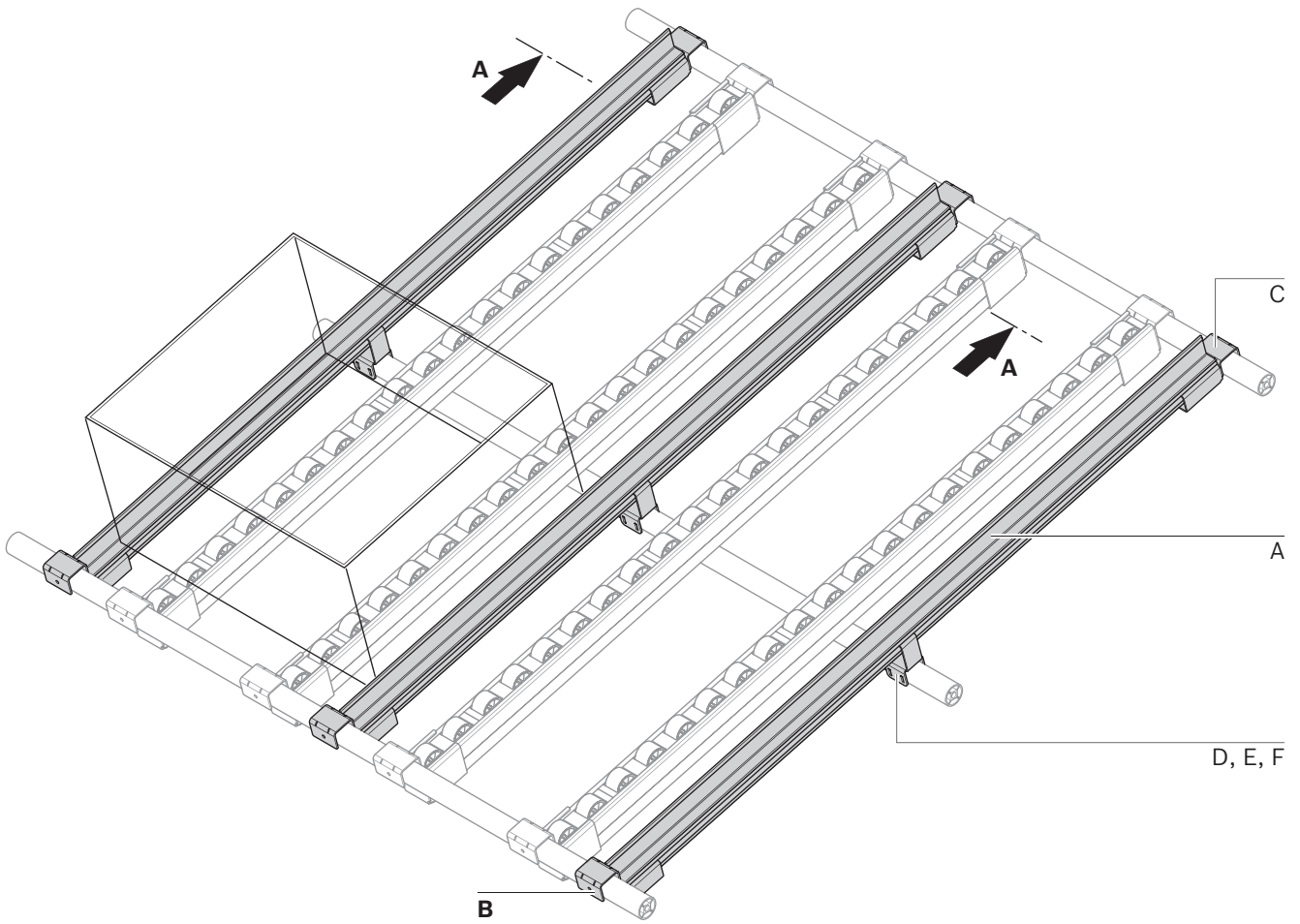
## Transport guide



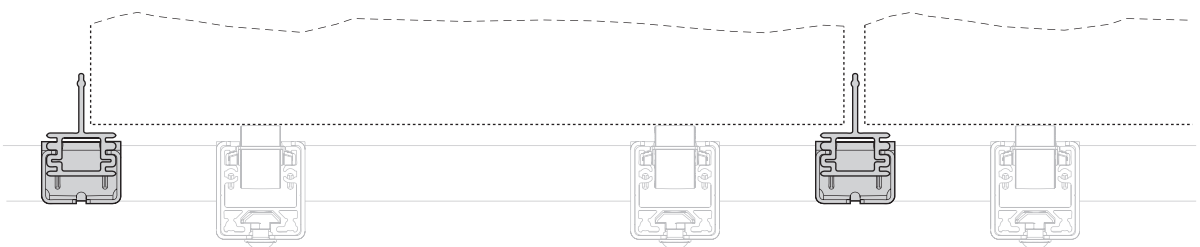
- ▶ Guide can be retrofitted onto XLean and Lean conveyor tracks
- ▶ Can be combined with all XLean and Lean conveyor media
- ▶ The T-shaped cross section allows both sides to be used as a lateral guide and a slide rail
- ▶ Use of both sides means lower space requirements
- ▶ Can be lowered underneath the conveyor track by turning the transport guide by 180°
- ▶ Mount for increased stability



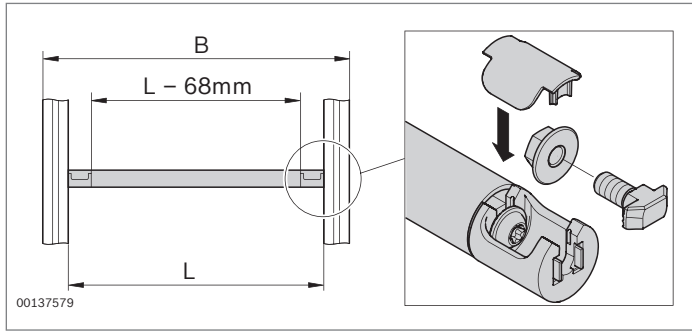
	L (mm)	ESD	ESD No.
<b>A</b> Plastic profile	30 ... 3000		<b>3 842 993 615/L</b>
	3000	20	<b>3 842 538 108</b>
	30 ... 3000		<b>3 842 993 617/L</b>
	3000	20	<b>3 842 538 107</b>
<b>B</b> Rail holder with stop		20	<b>3 842 538 051</b>
<b>C</b> Rail holder without stop		20	<b>3 842 538 050</b>
<b>D</b> XLean mount		20	<b>3 842 538 102</b>
<b>E</b> Mount Lean for RT, RTW, DRT		20	<b>3 842 538 052</b>
<b>F</b> Mount Lean for DRT with holder for double round tube		20	<b>3 842 538 130</b>



A - A



39875

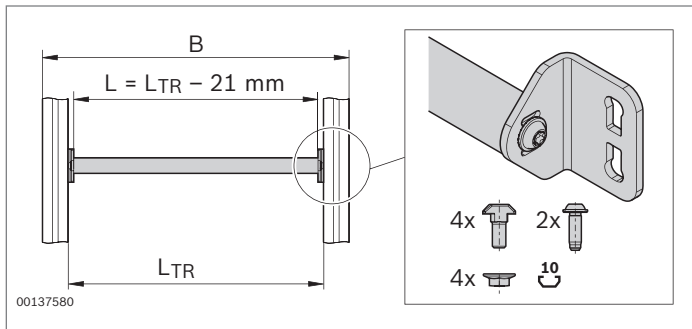


### Cross ties - components



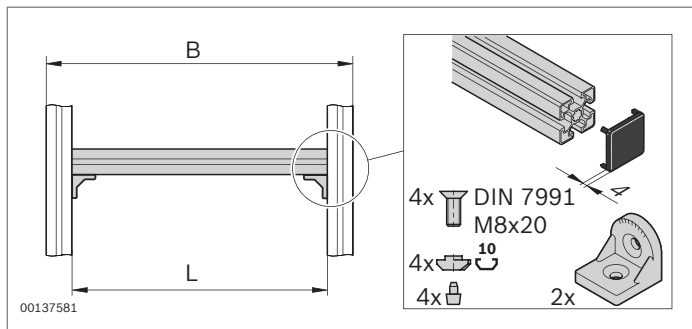
#### Tubular cross tie (RT)

- ▶ Space-saving, visually appealing design



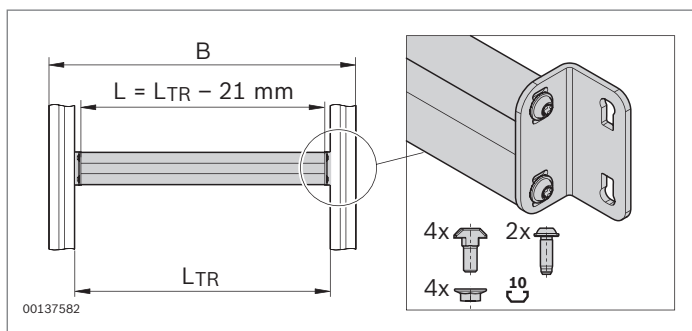
#### Tubular cross tie with bracket (RTW)

- ▶ Use of brackets makes for easy assembly
- ▶ Elongated hole for longitudinal compensation ( $\pm 3$  mm tolerance)



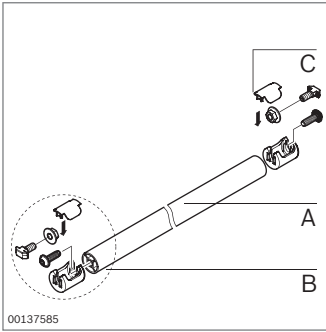
#### Profile cross tie (ST)

- ▶ Suitable for heavy loads
- ▶ Flexible usage thanks to integrated 10 mm slot

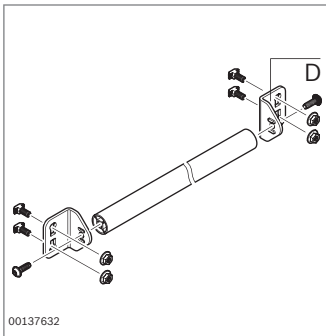


#### Double tubular cross tie (DRT)

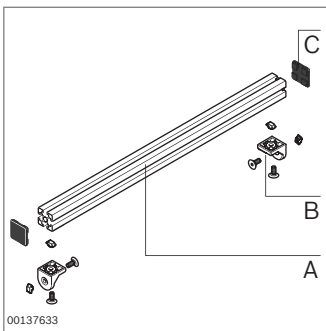
- ▶ Suitable for heavy loads
- ▶ Use of brackets makes for easy assembly
- ▶ Elongated hole for longitudinal compensation ( $\pm 3$  mm tolerance)



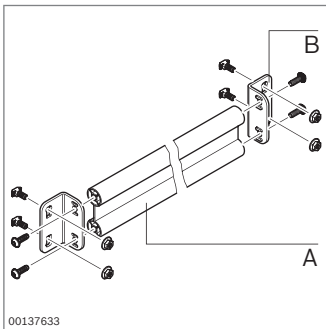
<b>Tubular cross tie (RT)</b>	<b>L (mm)</b>			<b>ESD</b>	<b>No.</b>
<b>A</b> D28 round tube (Ø28)	30 ... 6070				<b>3 842 993 317/L</b>
	6070				<b>3 842 546 212</b>
	6070	20			<b>3 842 535 118</b>
<b>B</b> D28 T-connector with cover cap, fastening material included			20		<b>3 842 532 879</b>
<b>C</b> Cover cap for D28 T-connector			20		<b>3 842 532 878</b>
<b>D</b> Bracket 60 x 47 x 4, incl. fastening material			20		<b>3 842 536 002</b>

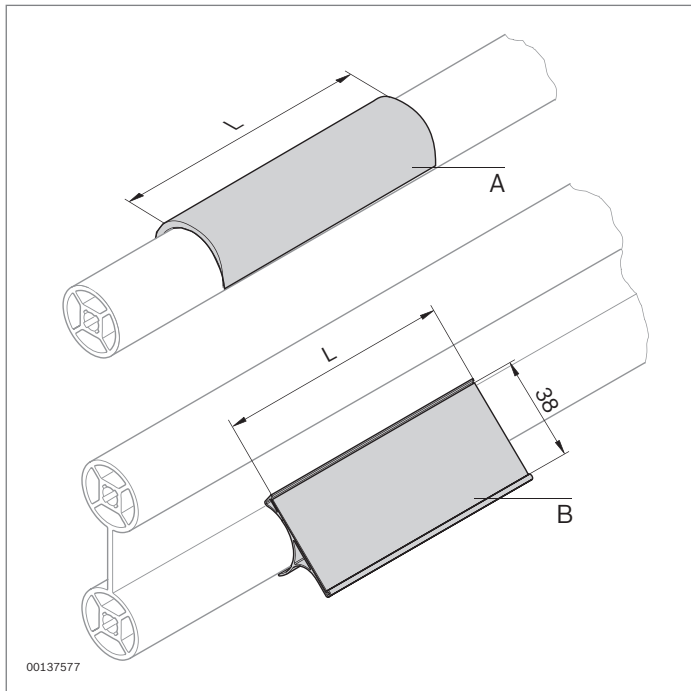


<b>Profile cross tie (ST)</b>	<b>L (mm)</b>			<b>ESD</b>	<b>No.</b>
<b>A</b> Profile 45 x 45L	50 ... 6070				<b>3 842 992 425/L</b>
	6070				<b>3 842 553 618</b>
	6070	20			<b>3 842 553 611</b>
<b>B</b> 40x43 bracket, incl. fastening material			100		<b>3 842 518 424</b>
<b>C</b> Cover cap 45 x 45, black			20		<b>3 842 548 753</b>
			100		<b>3 842 548 752</b>




<b>Double tubular cross tie (DRT)</b>	<b>L (mm)</b>			<b>No.</b>
<b>A</b> Strut profile D28 x 55	100 ... 6070			<b>3 842 993 489/L</b>
	6070			<b>3 842 564 214</b>
	6070	20		<b>3 842 537 477</b>
<b>B</b> Bracket 85 x 47 x 4, incl. fastening material			20	<b>3 842 536 730</b>





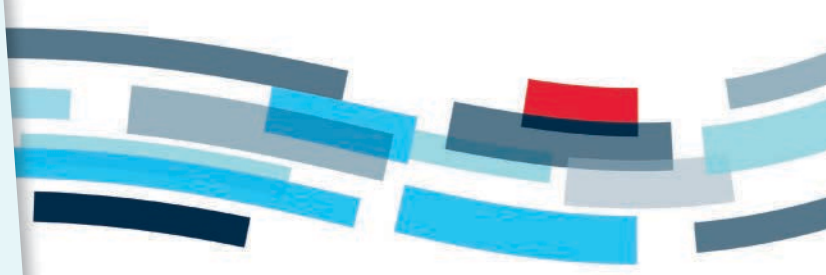
### Labeling clip

- ▶ For labeling cross ties in flow rack systems, workstations and material shuttles
- ▶ Self-adhesive
- ▶ With flat writing surface for tubular cross ties and double tubular cross ties and for EcoShape
- ▶ With rounded writing surface for tubular cross ties and double tubular cross ties and for EcoShape
- ▶ Max. label height: 38 mm

	L (mm)		No.
<b>A</b> Labeling clip for	2000	20	<b>3 842 535 136</b>
For tubular cross ties	102	20	<b>3 842 538 093</b>
<b>B</b> Labeling clip for	2000	20	<b>3 842 537 119</b>
Double tubular cross ties	102	20	<b>3 842 537 652</b>



5





## EcoShape – the tubular framing system for new dimensions

**With EcoShape, build custom solutions from just a few components. Planning is easy, too, not just due to the new MTpro planning software and the ability to make virtually any connection with just a few standard parts.**

The 35 standard components are designed in accordance with the poka yoke principle, making them quick to assemble and prohibiting any faulty connections. The assembly line can be improved and expanded at any time in line with the kaizen philosophy. The system allows you to quickly and economically custom plan and build flow racks, material shuttles, workstations and any other frame systems to meet your specific needs from just a few standard components.



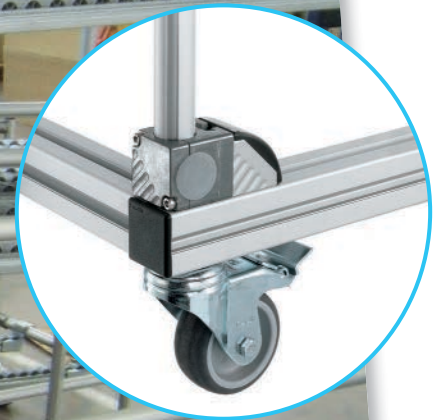
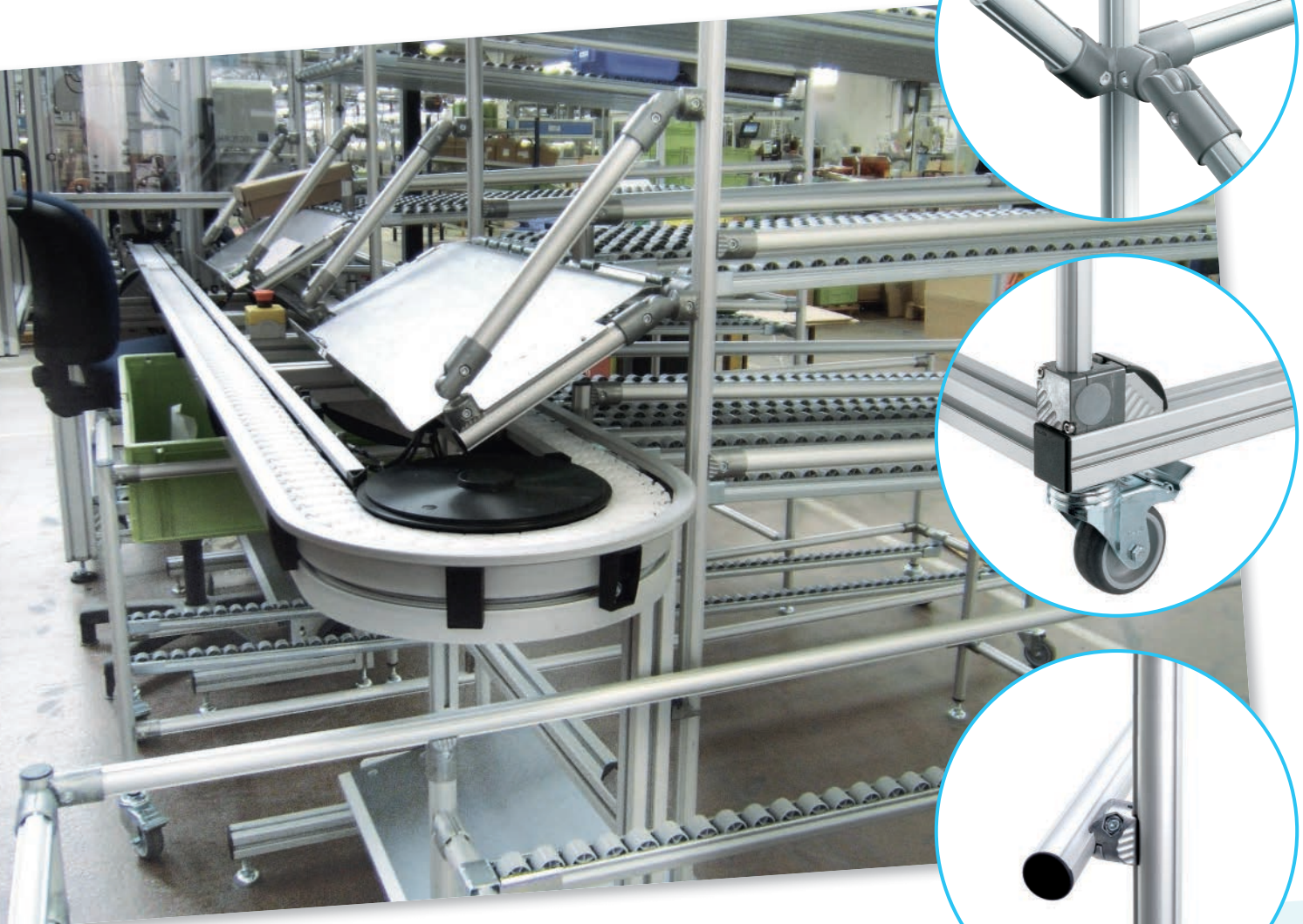
- ▶ Two aluminum tubular profiles give your construction the required stability.
- ▶ With just five connectors, you can create any connection between two EcoShape profiles – parallel, perpendicular, or at any desired angle.
- ▶ All of the connectors establish a positive interlocking connection between the profiles for a secure fit.
- ▶ The connection elements allow for a length tolerance, greatly facilitating cut-to-size and assembly work.
- ▶ The new Variofix blocks let you securely attach panel elements quickly and inexpensively.
- ▶ The combination with Rexroth's modular aluminum framing system enables solutions for handling heavy loads.
- ▶ EcoShape can be combined with the range of components from the Manual Production Systems (MPS) line. You can use this versatility to expand system functionality, for example in the area of ergonomics.

## OVERVIEW OF TUBULAR FRAMING SYSTEM

<b>6-7</b>	Round tube
<b>6-8</b>	Connector
<b>6-11</b>	Adapter



# EcoShape



**EcoShape stands for versatility.**  
**With EcoShape, you are ready for any challenge.**

- ▶ The ability to combine all components with one another gives you great flexibility with just a few components.
- ▶ The tubes and connectors will neither rust nor wear, making them ideal for long-term use and for reuse in new systems.
- ▶ For even greater stability, you can combine EcoShape with the modular aluminum framing system.

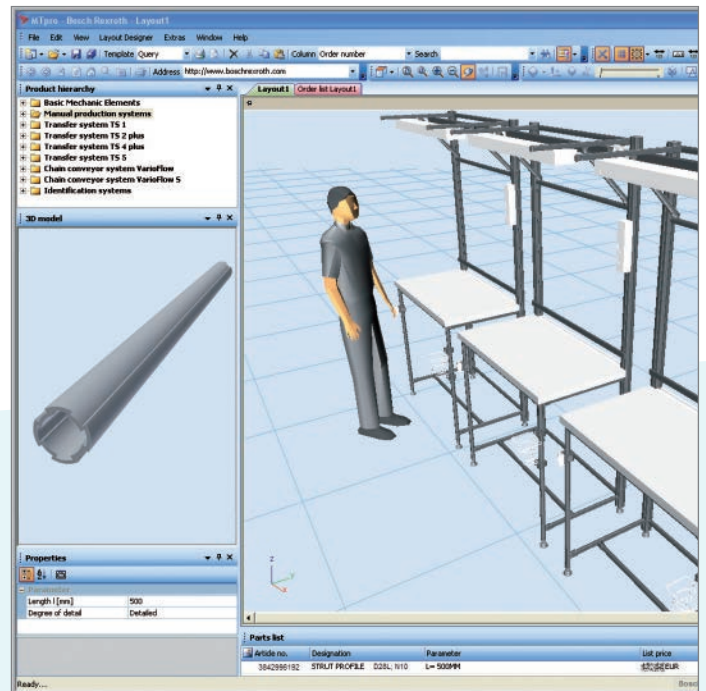
With the aid of just 35 EcoShape components, you can achieve continuous improvement (kaizen) and quickly and economically adapt existing systems to new demands on site.

All EcoShape systems are ESD-conductive and suitable for use in ESD-sensitive areas. All the connection elements are designed such that the anodized coating on the aluminum profiles is pierced to ensure ESD conductivity throughout the system without the need for risky additional wiring. No further ESD elements are required – with EcoShape you have everything in a single package.

- ▶ **MTpro** – the software for designing and planning constructions with the EcoShape tubular framing system. For further information, see pages 1-9/10 or [www.boschrexroth.com](http://www.boschrexroth.com)

## Ergonomics

The combination of lean production and ergonomics results in an unbeatable strategy to help you achieve short production runs and reduced costs. EcoShape unites low investment expenditure with high flexibility and quality, including in the area of ergonomics. The ergonomic accessories found in the MPS program can also be used with all EcoShape workstations and flow rack systems.



- ◀ **Aluminum is environmentally friendly and up to 99 % recyclable. Aluminum profiles are reusable.**



## EcoShape



- ▶ All connectors can be combined with the EcoShape D28L and D28L, N10 round tubes as well as with the D28 round tube (see "Flow rack systems" section, pages 5-3 ff.).
- ▶ Integrated poka-yoke system for easy and secure connector installation
  - Anti-torsion element for secure joints
  - Form-fit connection
- ▶ All connectors are suitable for setting up ESD-conductive systems.

Material: Diecast zinc

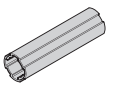
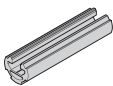
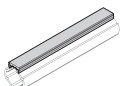
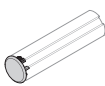
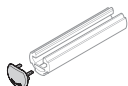
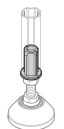

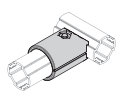
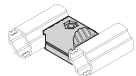
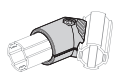
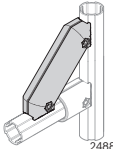

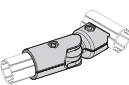
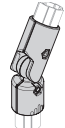
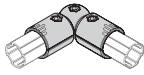
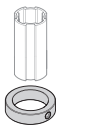
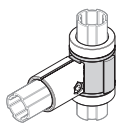
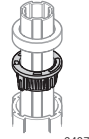
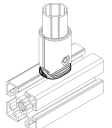

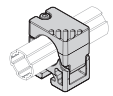
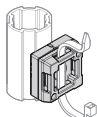
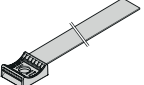
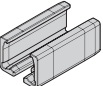
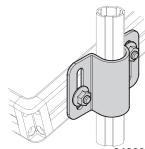
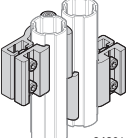
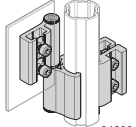
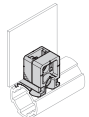
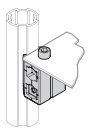
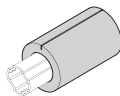

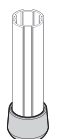
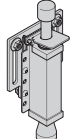
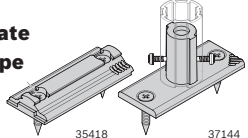
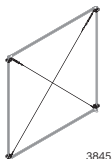
Scope of delivery: Incl fastening material



**35 components - countless options: The EcoShape system is characterized by its consistent simplicity and efficiency. Using just a few components, you can build complete assembly lines as well as simple transport shuttles.**

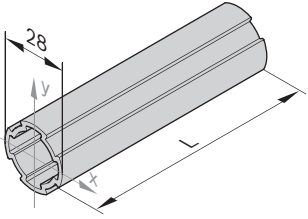
**See technical data page 13-18 f.**

00127214

	<p><b>1</b> Round tube D28L</p>  <p>24878</p>	<p><b>2</b> Round tube D28L, N10</p>  <p>24879</p>	<p><b>3</b> Slide rail</p>  <p>24880</p>
	<p><b>4</b> Cover cap D28L</p>  <p>24881</p>	<p><b>5</b> Cover cap D28L, N10</p>  <p>24882</p>	<p><b>6</b> Threaded sleeve D28L, PA</p>  <p>24883</p>
	<p><b>7</b> Threaded sleeve D28L, PA</p>  <p>24884</p>	<p><b>8</b> 90° connector</p>  <p>24885</p>	<p><b>9</b> Parallel connector</p>  <p>24886</p>
	<p><b>10</b> 45° connector</p>  <p>24887</p>	<p><b>11</b> Strut D28L, 45°</p>  <p>24888</p>	<p><b>12</b> Cross connector</p>  <p>24889</p>
	<p><b>13</b> 0°-90° connector</p>  <p>24890</p>	<p><b>14</b> D28 connector</p>  <p>24891</p>	<p><b>15</b> Corner bracket D28</p>  <p>24892</p>
<p><b>16</b> Retaining ring D28L</p>  <p>24893</p>	<p><b>17</b> Swivel bearing D28L</p>  <p>24894</p>	<p><b>18</b> Bushing</p>  <p>34277</p>	<p><b>19</b> Adapter N8, N10</p>  <p>24895</p>
<p><b>20</b> Adapter N10/45</p>  <p>24896</p>	<p><b>21</b> Adapter N10/30</p>  <p>24897</p>	<p><b>22</b> Adapter mount D28L</p>  <p>24898</p>	<p><b>Adapter D28L</b> Cable bracket loop</p>  <p>37123</p>
<p><b>23</b> Adapter XLean</p>  <p>24899</p>	<p><b>24</b> Tube clamp D28L, N10</p>  <p>24900</p>	<p><b>25</b> Hinge D28I/D28L</p>  <p>24901</p>	<p><b>26</b> Hinge D28L/-</p>  <p>24902</p>
<p><b>27</b> Variofix block PA</p>  <p>24903</p>	<p><b>28</b> Variofix block Zn</p>  <p>24904</p>	<p><b>29</b> Impact protection</p>  <p>24905</p>	<p><b>30</b> Ring D50</p>  <p>24906</p>
<p><b>31</b> Rubber foot D28</p>  <p>24907</p>	<p><b>32</b> Stopper D28L, N10</p>  <p>24908</p>	<p><b>33/34</b> Base plate EcoShape</p>  <p>35418 37144</p>	<p><b>35</b> Tension wire</p>  <p>38453</p>

**1**

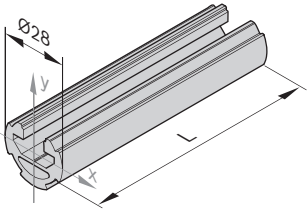

$A = 1,80 \text{ cm}^2$   
 $I_x = 1,33 \text{ cm}^4$   
 $I_y = 1,33 \text{ cm}^4$   
 $W_x = 0,95 \text{ cm}^3$   
 $W_y = 0,95 \text{ cm}^3$   
 $m = 0,48 \text{ kg/m}$



00134985

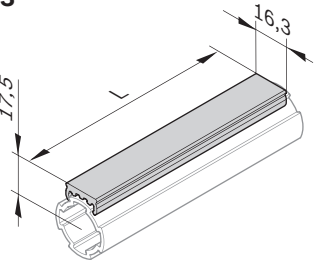
**2**

$A = 2,63 \text{ cm}^2$   
 $I_x = 1,17 \text{ cm}^4$   
 $I_y = 1,97 \text{ cm}^4$   
 $W_x = 0,84 \text{ cm}^3$   
 $W_y = 1,41 \text{ cm}^3$   
 $m = 0,71 \text{ kg/m}$

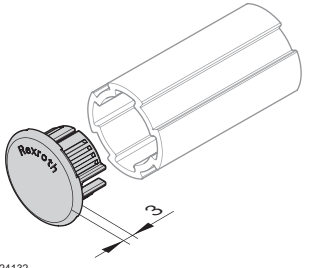
00134986

**3**



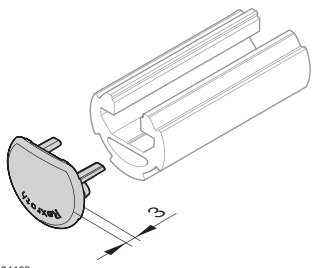
00134987

**4**



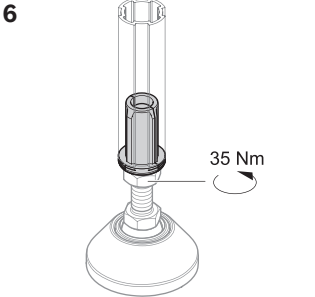
24132

**5**

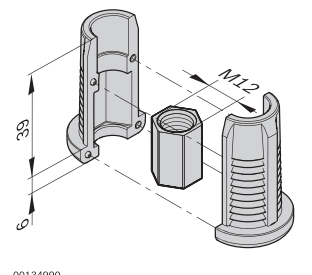


24133

**6**



25597



00134990

<b>D28L round tube</b>		<b>L (mm)</b>	<b>No.</b>
1 pc		50 ... 6070	<b>3 842 996 191/L</b>
50 pcs		6070	<b>3 842 557 243</b>
1 pc		6070	<b>3 842 557 250</b>

- ▶ D28L round tube with 4 interfaces for attaching EcoShape connectors

Material: Aluminum, anodized

<b>D28L round tube, N10</b>		<b>L (mm)</b>	<b>No.</b>
1 pc		50 ... 6070	<b>3 842 996 192/L</b>
20 pcs		6070	<b>3 842 557 244</b>
1 pc		6070	<b>3 842 557 251</b>

- ▶ D28L round tube, N10 with 10 mm slot for mounting accessories from the modular aluminum framing system
- ▶ 3 interfaces for EcoShape connectors

Material: Aluminum, anodized

<b>Slide rail</b>	<b>L (mm)</b>	<b>ESD</b>		<b>No.</b>
	2000		10	<b>3 842 554 750</b>
	2000		10	<b>3 842 548 117</b>

- ▶ Slide rail for creating a simple conveyor track or manual slide section by clipping the slide rail onto the D28L round tube or D28L, N10 round tube

Material: PVC, signal gray; ESD: PVC (conductive), black

<b>Cover cap</b>		<b>ESD</b>		<b>No.</b>
<b>4</b> D28L	Black		20	<b>3 842 548 129</b>
	Signal gray		20	<b>3 842 554 752</b>
<b>5</b> D28L, N10	Black		20	<b>3 842 548 130</b>
	Signal gray		20	<b>3 842 554 754</b>

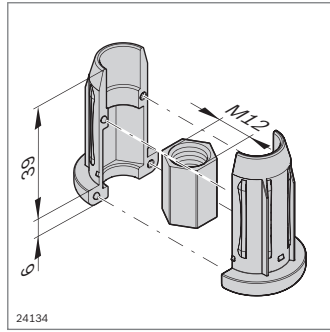
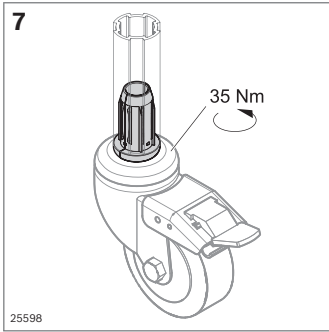
- ▶ Cover cap for D28L round tube and D28L, N10 round tube

Material: PA66 (conductive)

<b>D28L threaded sleeve, PA</b>	<b>ESD</b>		<b>No.</b>
		20	<b>3 842 541 185</b>

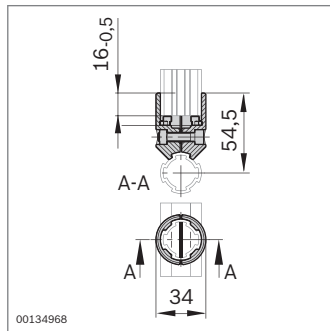
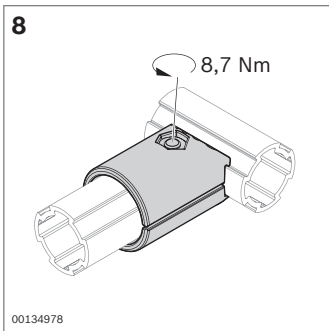
- ▶ Threaded sleeve for incorporating a leveling foot or castor wheel. For further information, see page 6-7

Material: PA66 (conductive), black; aluminum hexagon nut



D28L threaded sleeve, Zn	ESD	No.
	20	3 842 548 119

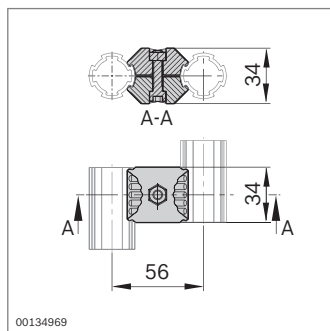
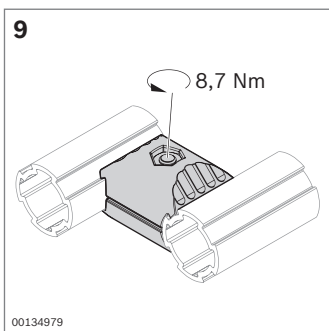
Material: Diecast zinc; aluminum hexagon nut



90° connector	ESD	No.	FS
	20	3 842 541 173	FS1

Material: Diecast zinc  
Scope of delivery: Incl fastening material (FS)

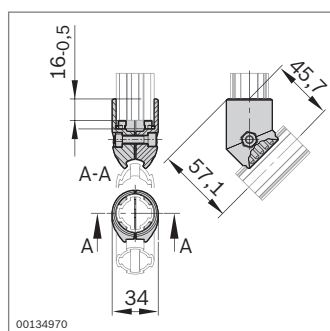
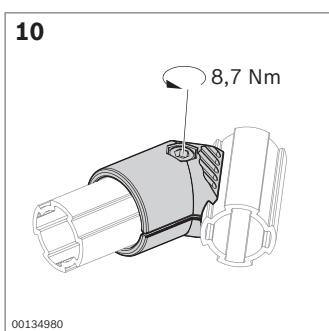
- FS1**
- ISO 4762 M6x25
  - ISO 10511 M6



Parallel connector	ESD	No.	FS
	20	3 842 541 183	FS1

Material: Diecast zinc  
Scope of delivery: Incl fastening material (FS)

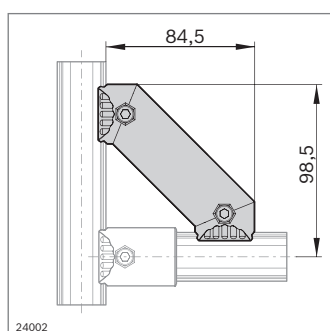
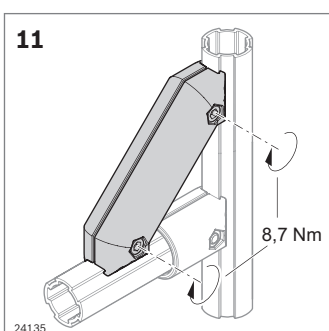
- FS1**
- ISO 4762 M6x25
  - ISO 10511 M6



45° connector	ESD	No.	FS
	20	3 842 541 175	FS1

Material: Diecast zinc  
Scope of delivery: Incl fastening material (FS)

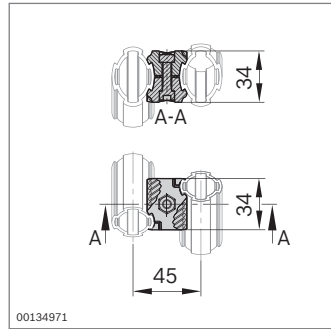
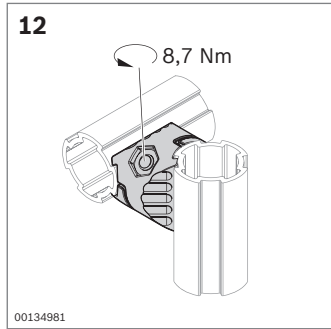
- FS1**
- ISO 4762 M6x25
  - ISO 10511 M6



45° D28L strut	ESD	No.	FS
	20	3 842 548 118	2xFS1

Material: Diecast zinc  
Scope of delivery: Incl fastening material (FS)

- FS1**
- ISO 4762 M6x25
  - ISO 10511 M6



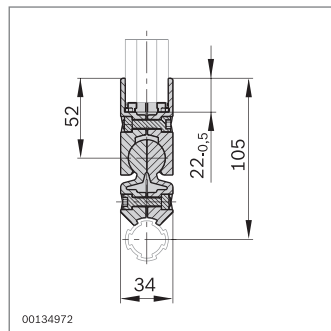
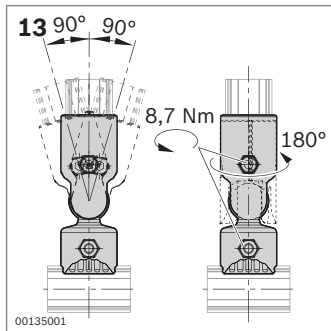
Cross connector	ESD	No.	FS
	20	3 842 541 181	FS1

Material: Diecast zinc

Scope of delivery: Incl fastening material (FS)

**FS1**

ISO 4762	M6x25
ISO 10511	M6



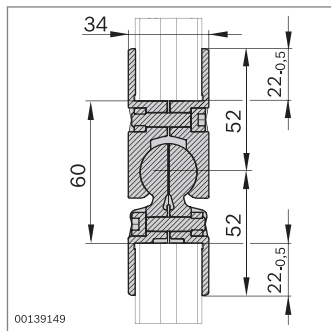
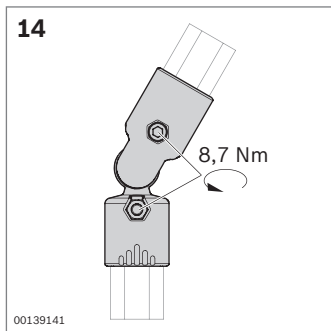
0°-90° connector	ESD	No.	FS
	20	3 842 541 178	2xFS1

Material: Diecast zinc

Scope of delivery: Incl fastening material (FS)

**FS1**

ISO 4762	M6x25
ISO 10511	M6



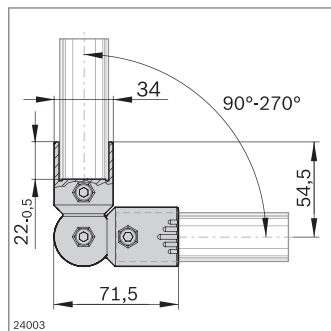
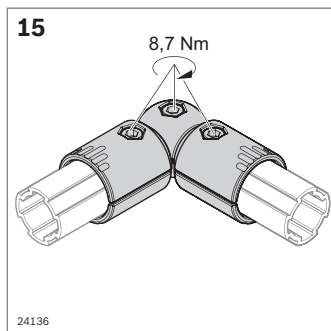
0°-90° D28 connector	ESD	No.	FS
	20	3 842 543 480	2xFS1

Material: Diecast zinc

Scope of delivery: Incl fastening material (FS)

**FS1**

ISO 4762	M6x25
ISO 10511	M6



D28 corner bracket	ESD	No.	FS
	20	3 842 548 123	3xFS1

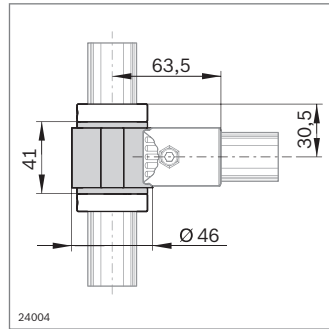
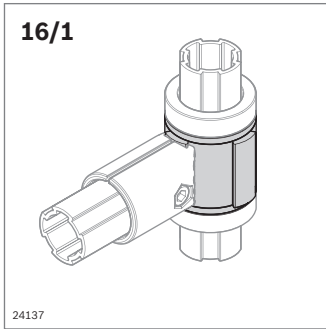
- ▶ D28 corner bracket for easy adjustment within a 15° range
- ▶ Swivel range: 90°-270°

Material: Diecast zinc

Scope of delivery: Incl fastening material (FS)

**FS1**

ISO 4762	M6x25
ISO 10511	M6



D28L swivel bearing	L (mm)		No.
	34	20	<b>3 842 548 121</b>

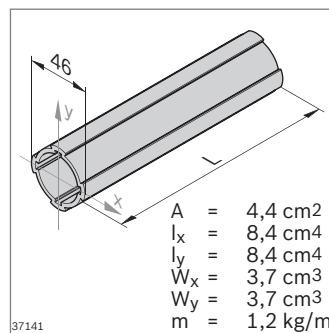
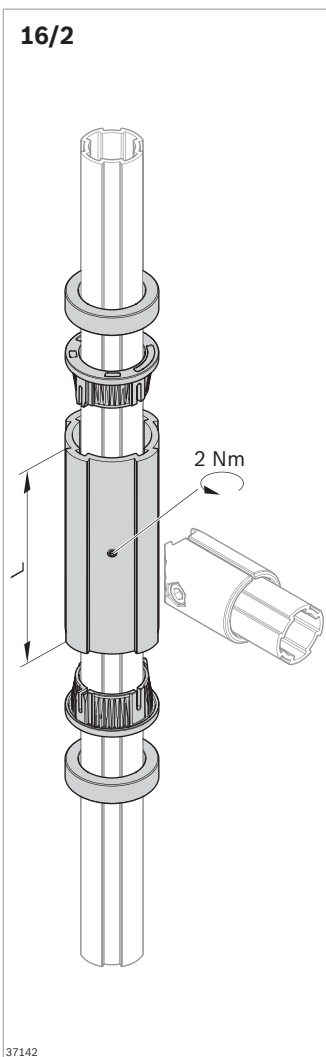
- ▶ For axial shifting along the D28L or D28L, N10 round tube. The retaining ring determines the end position
- ▶ Construction of swiveling applications
- ▶ Additional thread for flexible bracket adjustment

Required accessories: D28L retaining ring

Material: Aluminum swivel bearing

Scope of delivery: D28L swivel bearing, L=34 mm;

D28 bushing (17), headless setscrew ISO 4026 M4x10

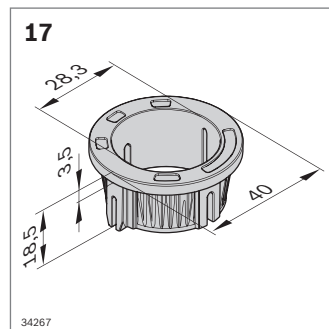


D28L swivel bearing	L (mm)		No.
	1000	2	<b>3 842 557 298</b>

For self-assembly:

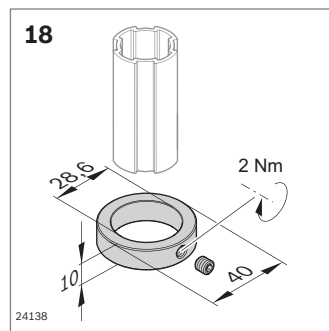
- ▶ D28L swivel bearing with L = 1000 mm that can be cut to length

Material: Aluminum swivel bearing



D28 bushing		No.
	4	<b>3 842 557 299</b>

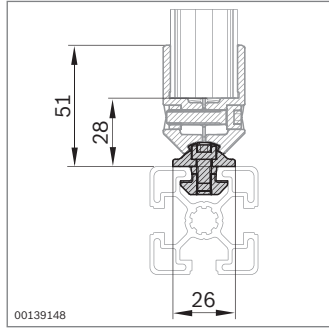
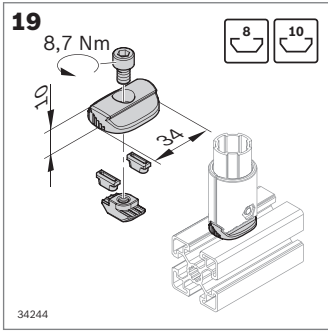
Material: POM bushing, black



D28L retaining ring	ESD		No.
		4	<b>3 842 548 122</b>

Material: Aluminum retaining ring

Scope of delivery: Retaining ring incl. headless setscrew DIN 913 M6x6



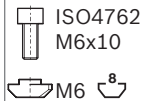
N8, N10 adapter	ESD	No.	FS
	20	3 842 543 272	FS4, FS5

- N8, N10 adapter for connecting an MGE strut profile (8 mm, 10 mm slots)

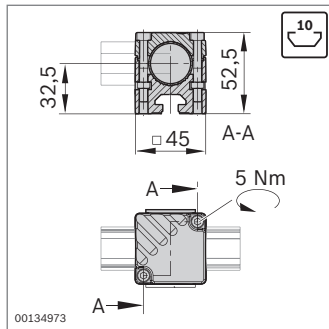
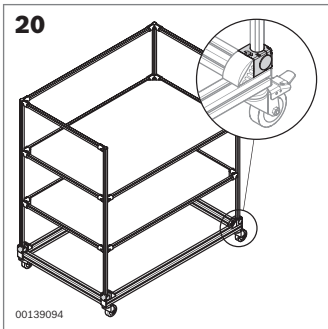
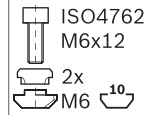
Material: Diecast zinc

Scope of delivery: Incl fastening material (FS)

**FS4**



**FS5**



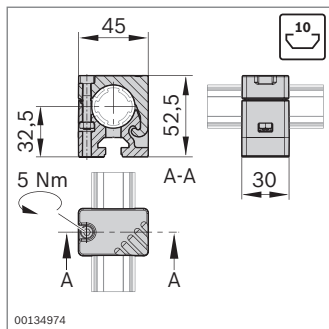
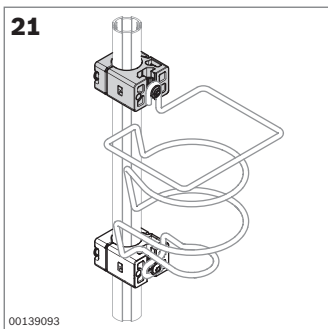
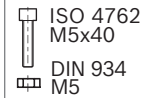
N10/45 adapter	ESD	No.	FS
	20	3 842 541 187	2xFS3

- N10/45 adapter for connecting D28L round tubes or D28L, N10 round tubes to profiles with a 10 mm slot

Material: Diecast zinc adapter, PE cover cap

Scope of delivery: Incl cover cap, fastening material (FS)

**FS3**



N10/30 adapter	ESD	No.	FS
	20	3 842 541 190	FS6

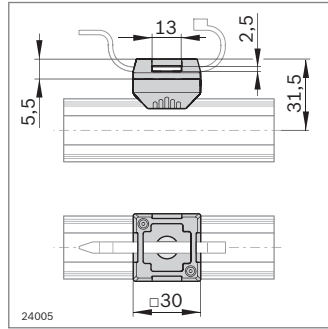
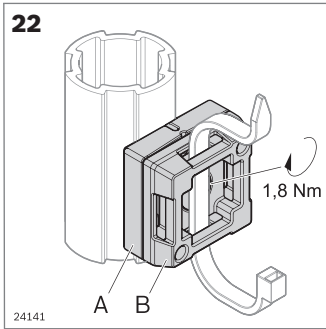
- N10/30 adapter for mounting light accessories such as a bottle holder to the D28L round tube

Material: Diecast zinc

Scope of delivery: Incl fastening material (FS)

**FS6**



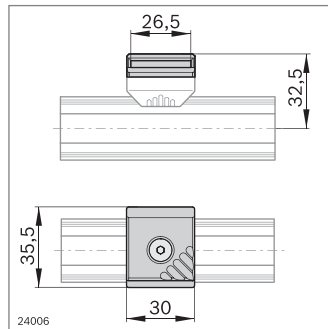
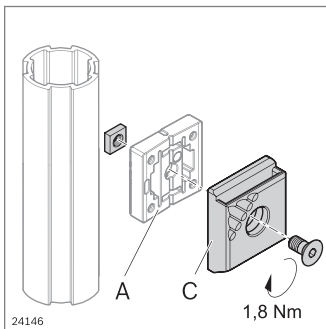
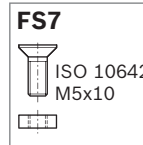


D28L adapter mount	ESD	No.	FS
A + B	20	3 842 548 120	FS7

► For attaching cable ties

Material: PA66 (conductive), black

Scope of delivery: Incl fastening material (FS)

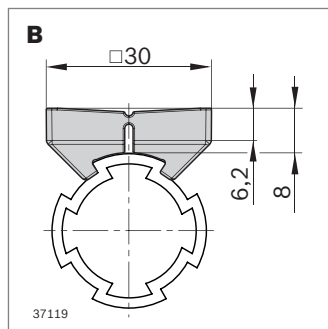
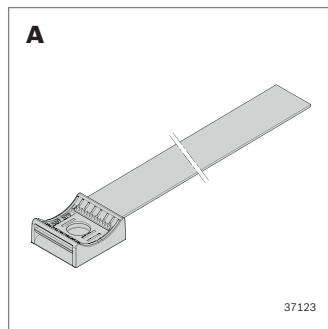
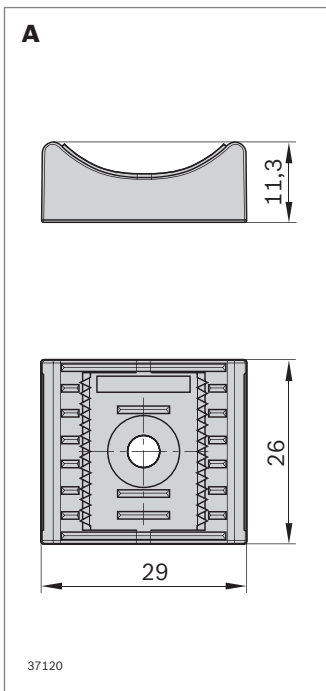
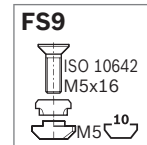
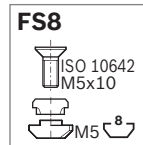


Container mount	ESD	No.	FS
C	10	3 842 544 797	FS8, FS9

► For attaching containers using the container mount

Material: PA66 (conductive), black

Scope of delivery: Incl fastening material (FS)

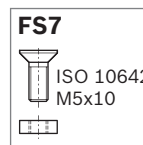


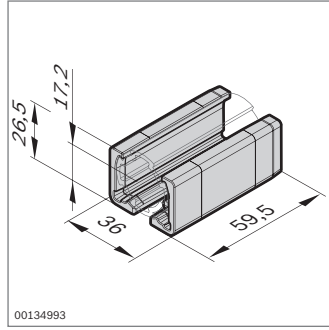
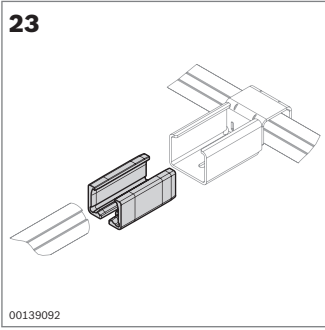
Cable bracket + adapter	ESD	No.	FS
A Loop flat cable bracket	10	3 842 559 380	
B Adapter D28L	10	3 842 562 115	FS7

- Loop flat cable bracket (A) for the direct assembly on panel element or table top
- Can be mounted on adapter D28L (B) for the fastening on EcoShape profiles
- Can be used with M4 and M5 screws
- Adapter for the fastening of loop flat cable holder at EcoShape profiles
- D28L adapter (B) for the fastening of container mount

Material: PP cable bracket (conductive), black, UL certified; PP velcro strap, PPA (velour), UL certified; PA adapter (conductive), black; steel mounting kit, galvanized

Scope of delivery: Adapter incl. fastening material (FS)

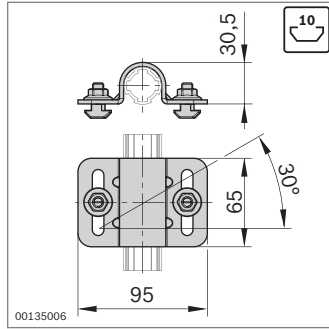
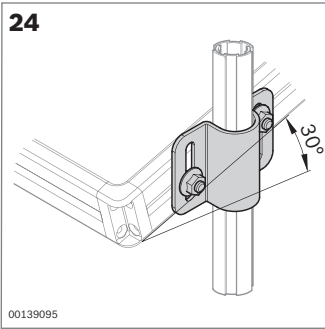




XLean adapter	ESD	No.
	20	<b>3 842 541 296</b>

- ▶ XLean adapter for combination with XLean. The XLean adapter connects the D28L round tube with the XLean rail holder (page 6-13)

Material: PA66 (conductive), black



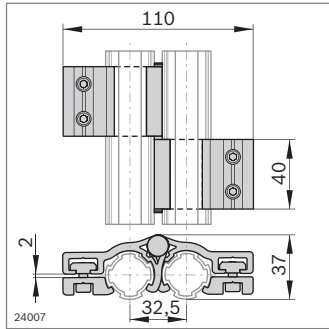
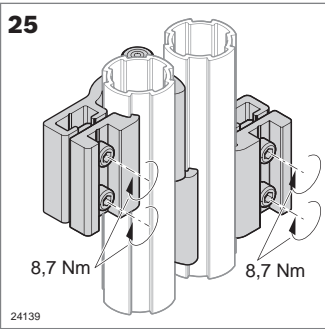
D28L, N10 tube clamp	ESD	No.	FS
	20	<b>3 842 541 193</b>	2xFS10

- ▶ Tube clamp D28L, N10 for fastening material shelves with a 10 mm slot to the D28L round tube; oblique positioning up to 30 degrees is possible

Material: Steel, galvanized, black

Scope of delivery: Incl fastening material (FS)

**FS10**



D28L/D28L hinge	ESD	No.	FS
	2	<b>3 842 548 126</b>	4xFS11, FS12

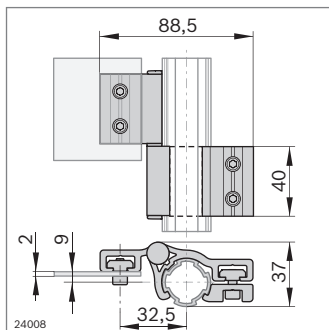
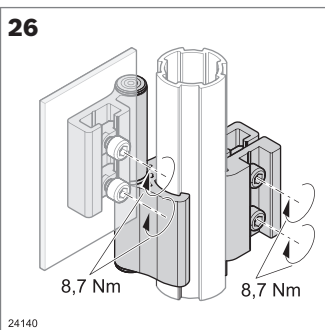
- ▶ Opening angle: 180°
- ▶ For mounting D28L round tube

Material: Aluminum

Scope of delivery: Incl fastening material (FS)

**FS11**

**FS12**



D28L/- hinge	ESD	No.	FS
	2	<b>3 842 548 127</b>	2xFS11, FS12

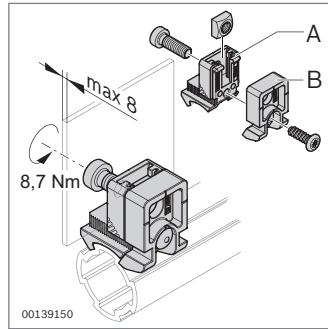
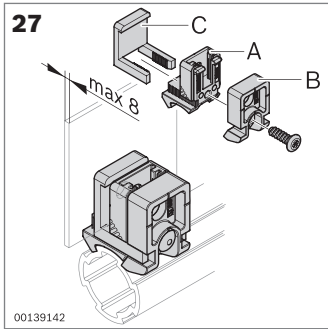
- ▶ Opening angle: 180°
- ▶ For mounting panel elements

Material: Aluminum

Scope of delivery: Incl fastening material (FS)

**FS11**

**FS12**



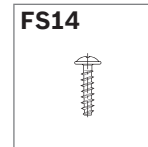
Variofix block (PA)	No.	FS
	20 3 842 543 311	FS13, FS14

- ▶ Plastic Variofix block for fastening panel elements with snap-in clips or a screw
- ▶ Variofix remover for releasing the snap-in clip (page 6-14)

Material: PA66 (conductive), black

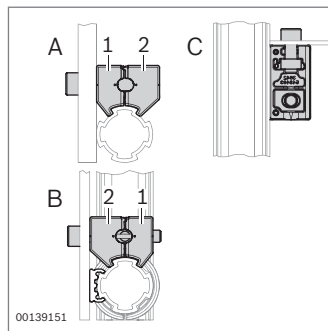
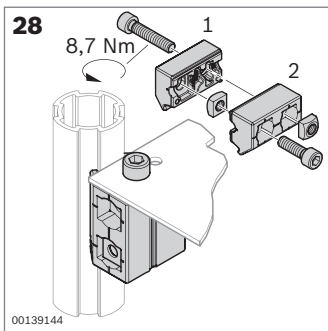
Scope of delivery: Incl fastening material (FS)

FS13
<ul style="list-style-type: none"> <li>ISO 4762 M6x16</li> <li>DIN 557 M6</li> </ul>



Snap-in clip	No.
	10 3 842 184 738

Material: PA6, transparent



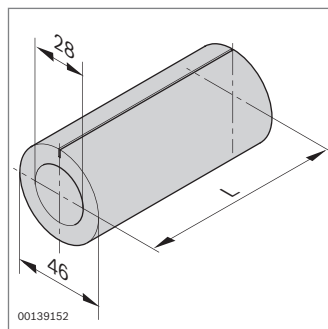
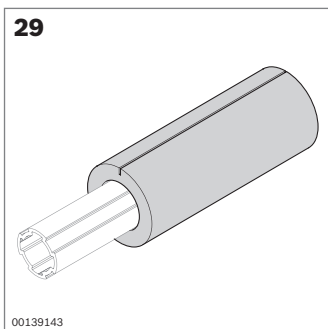
Variofix block (Zn)	ESD	No.	FS
		20 3 842 543 494	FS15

- ▶ Diecast zinc Variofix block for fastening panel elements
- ▶ Three arrangements possible ("A", "B", "C")

Material: Diecast zinc

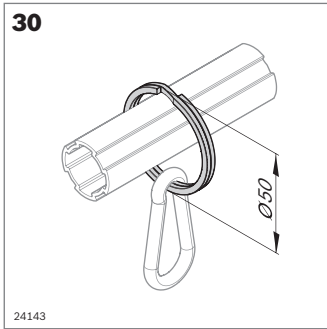
Scope of delivery: Incl fastening material (FS)


FS15
<ul style="list-style-type: none"> <li>ISO 4762 M6x22</li> <li>ISO 4762 M6x30</li> <li>DIN 557 M6</li> </ul>



Impact protection	L (mm)	No.
	2000 10	3 842 544 637

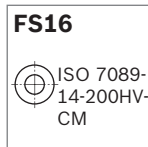
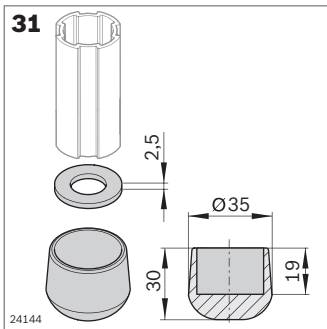
Material: PE-LD, gray




Ring + spring hook		No.
D50 ring	20	<b>3 842 548 131</b>
Spring hook	1	<b>0 842 901 309</b>

► For designing simple tool holders

Material: Steel ring, nickel-plated; steel spring hook, galvanized

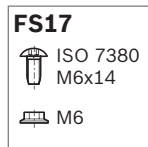
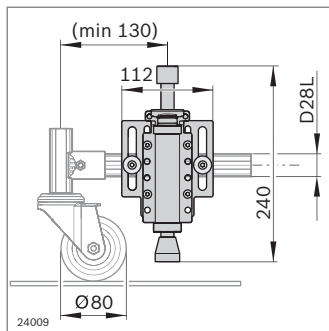
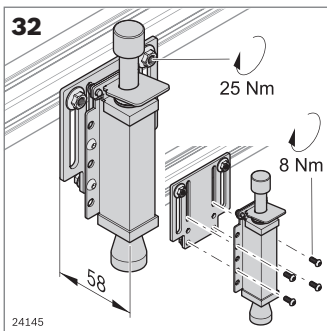


**FS16**  
 ISO 7089-14-200HV-CM




D28L base plate	ESD		No.	FS
		20	<b>3 842 548 128</b>	FS16

► Non-slip design of flow racks and stands

Material: NR/SBR (conductive), black



**FS17**  
 ISO 7380 M6x14  
 M6

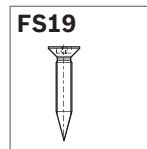
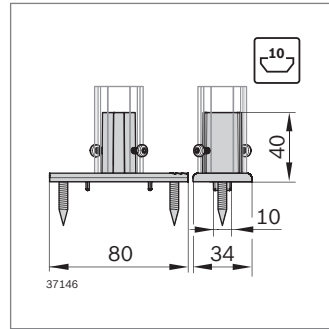
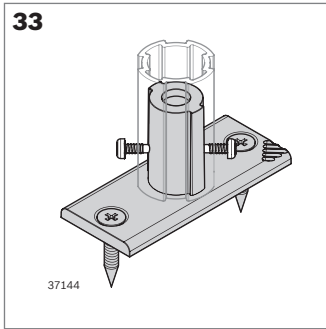
**FS18**  
 ISO 7380 M6x35  
 DIN9021 6,4 M8  
 M8x20

D28L, N10 stopper	No.	FS
	<b>3 842 548 132</b>	4xFS16, 2x FS18

- To stop material shuttles ergonomically at just one point
- All-purpose option for attachment to different round tubes and profile cross-sections
- Stopper tension path: 34 mm

Material: Stainless steel stopper: EPDM; aluminum attachment plate

Scope of delivery: Incl fastening material (FS)



D28L base plate	ESD	No.	FS
	10	<b>3 842 559 346</b>	2xFS19

- ▶ Base plate for fastening frames directly onto walls, floors, table tops and strut profiles with 10 mm slot via EcoShape round tubes
- ▶ No additional connector required
- ▶ Anti-torsion element by centering lug (can be broken off)
- ▶ Reference load during profile installation: 15 Nm admissible in lengthwise and crosswise direction. Load values at installation on other surfaces depend on the respective material

Material: Diecast zinc

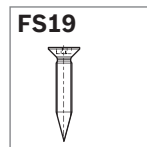
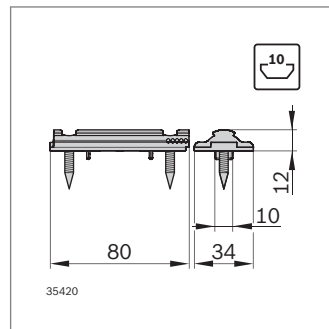
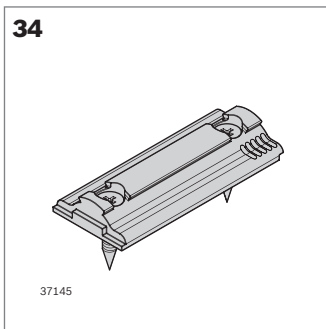
Scope of delivery: Incl fastening material (FS)

Recommended accessories for profile installation:

Countersunk screw ISO 10642 M5x16-8.8; T-nut

**(3 842 530 283)**

Optional accessories: Self-tapping screw **(3 842 552 267)**



EcoShape base plate	ESD	No.	FS
	10	<b>3 842 559 345</b>	2xFS19

- ▶ Base plate for fastening frames onto walls, floors, table tops and strut profiles with 10 mm slot with the help of EcoShape connectors
- ▶ Anti-torsion element by centering lug (can be broken off)
- ▶ Reference load during profile installation: 15 Nm admissible in lengthwise and crosswise direction. Load values at installation on other surfaces depend on the respective material

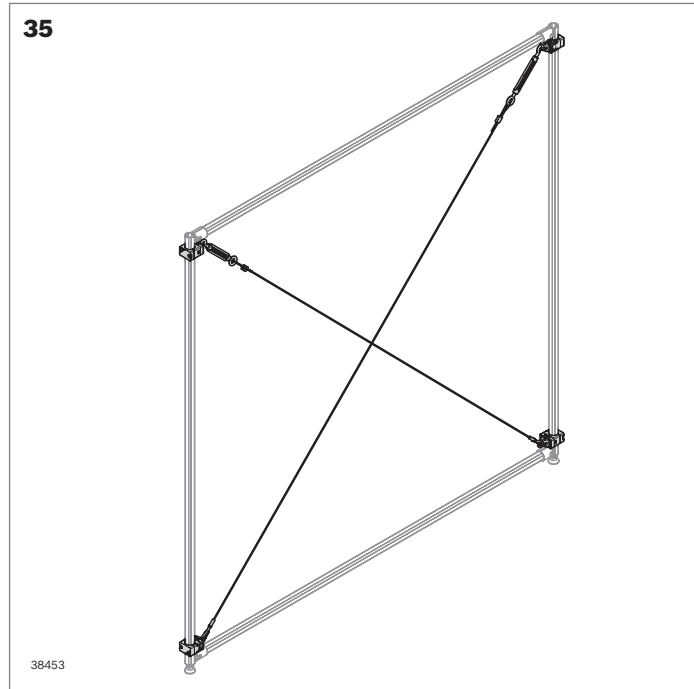
Material: Diecast zinc

Scope of delivery: Incl fastening material (FS)

Recommended accessories for profile installation:

Countersunk screw ISO 10642 M5x16-8.8; T-nut

**(3 842 530 283)**

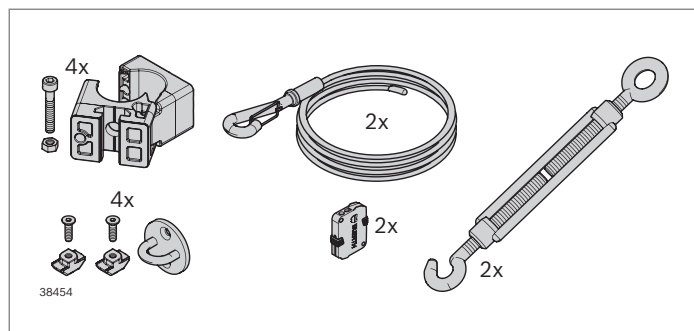


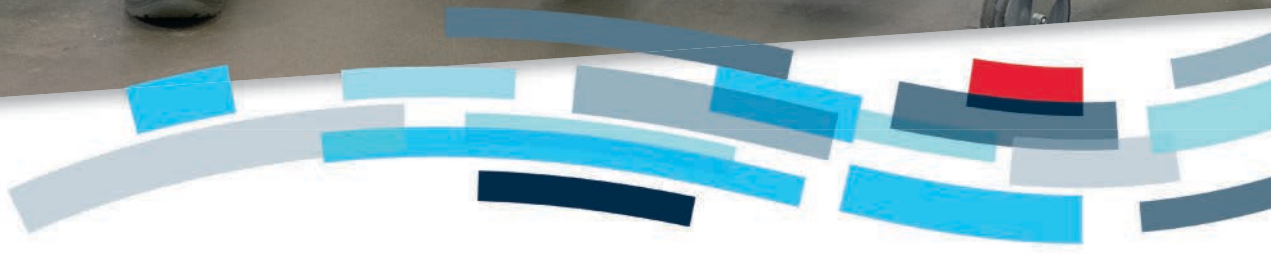
Tension wire	ESD	No.
	2	<b>3 842 562 083</b>

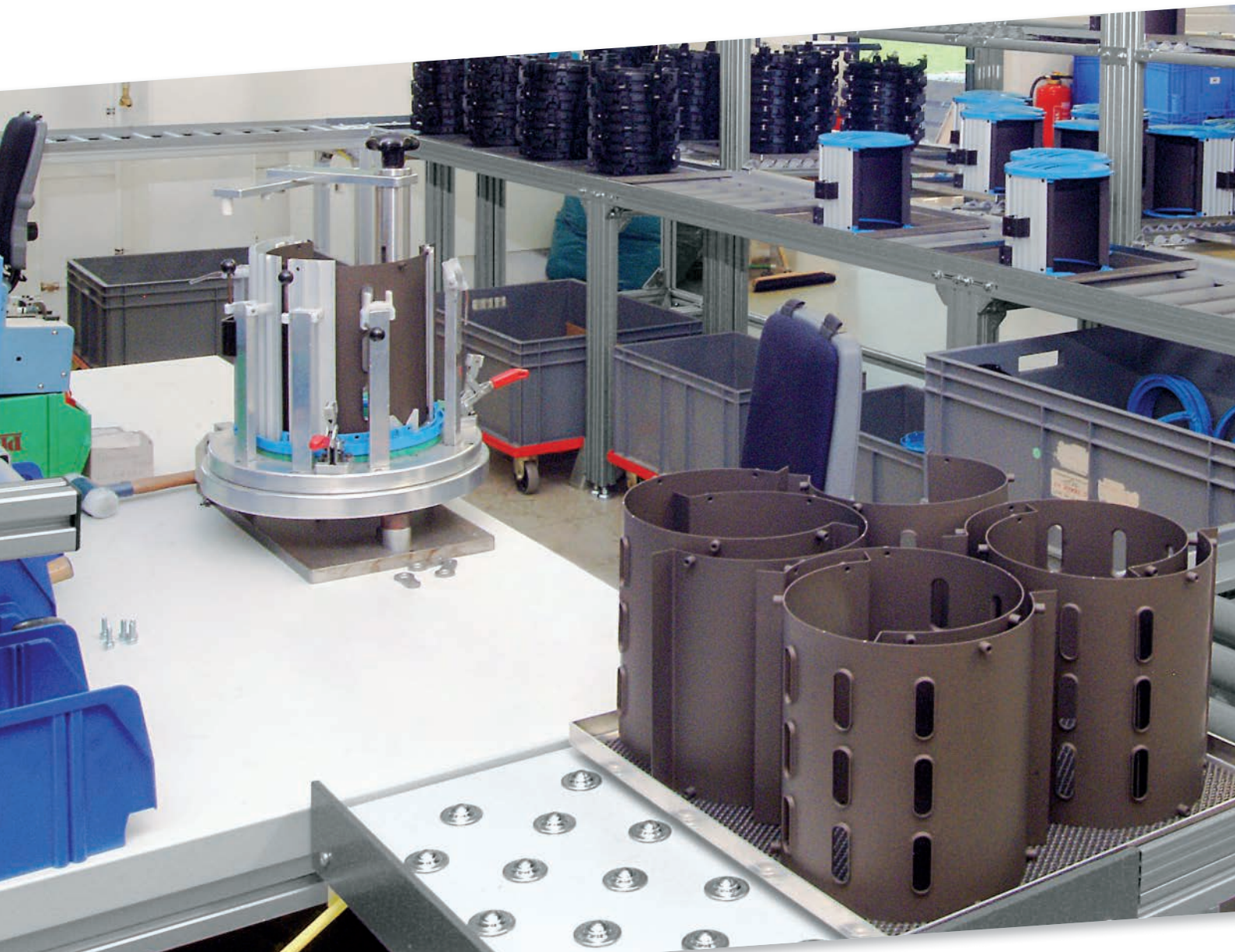
- ▶ Reinforcement option for EcoShape applications
- ▶ Max. tensioning force 500 N

Material: eye, locking lock, stainless steel: Steel wire, galvanized

Scope of delivery: Incl fastening material for fastening to the D28L round tube



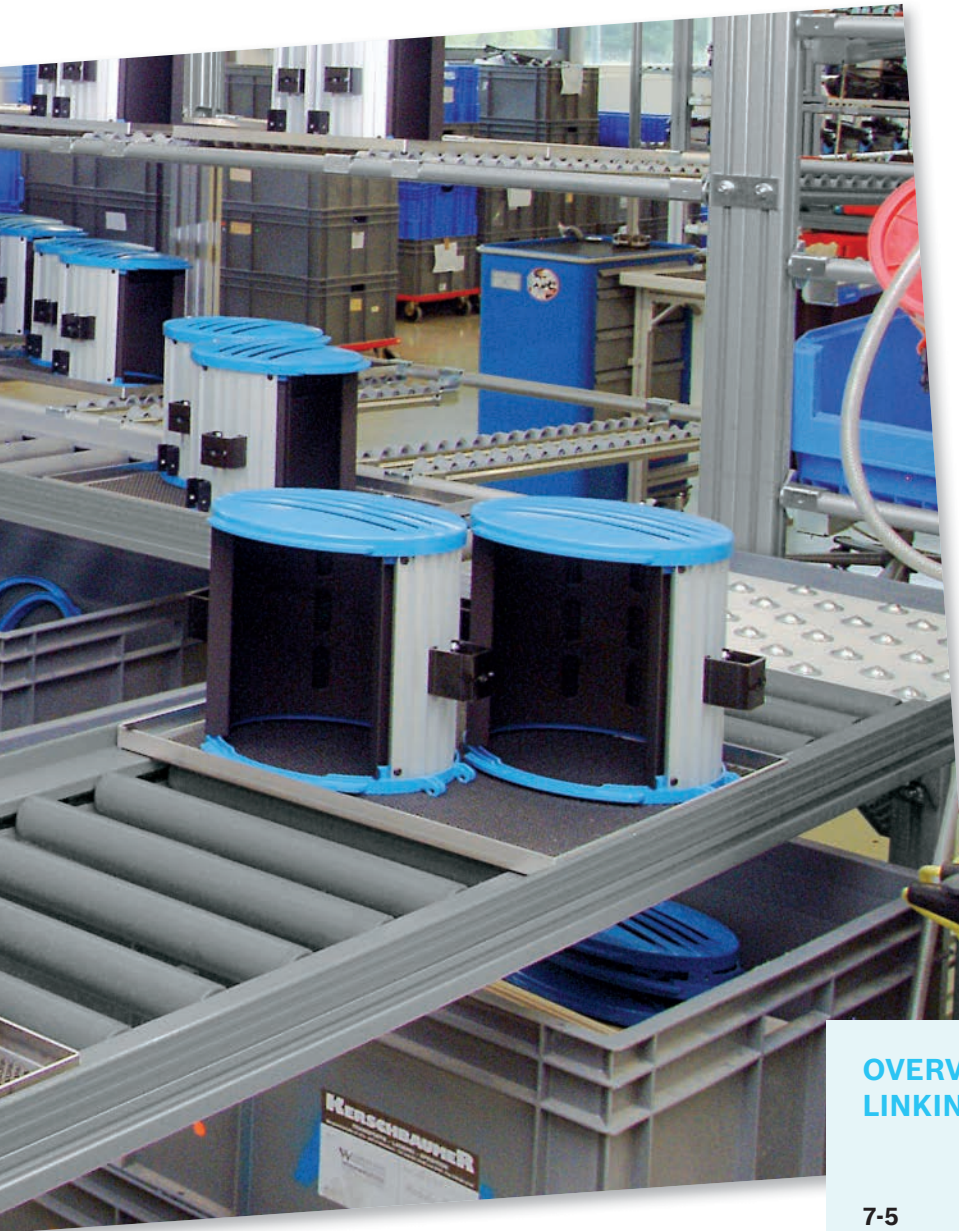




## EcoFlow – manual linking elements bring everything closer

**Manually linking workstations with EcoFlow eases employee strain because products and workpiece pallets are conveyed on manual slide sections.**

Assembly line operations are normally divided among multiple workstations. Besides making these workstations ergonomic, assembly line designers must also ensure that the various jobs and workstations are linked together in a way that maximizes efficiency and economy. Workers do not have to carry loads. At the same time, investment in this linking remains low, since the EcoFlow conveyor tracks work without any electric drive systems or controllers.



## OVERVIEW OF ECOFLOW LINKING ELEMENTS

- 7-5**      Conveyor tracks
- 7-7**      Conveyor track components
- 7-11**    Stop gates and return stops
- 7-12**    Accessories

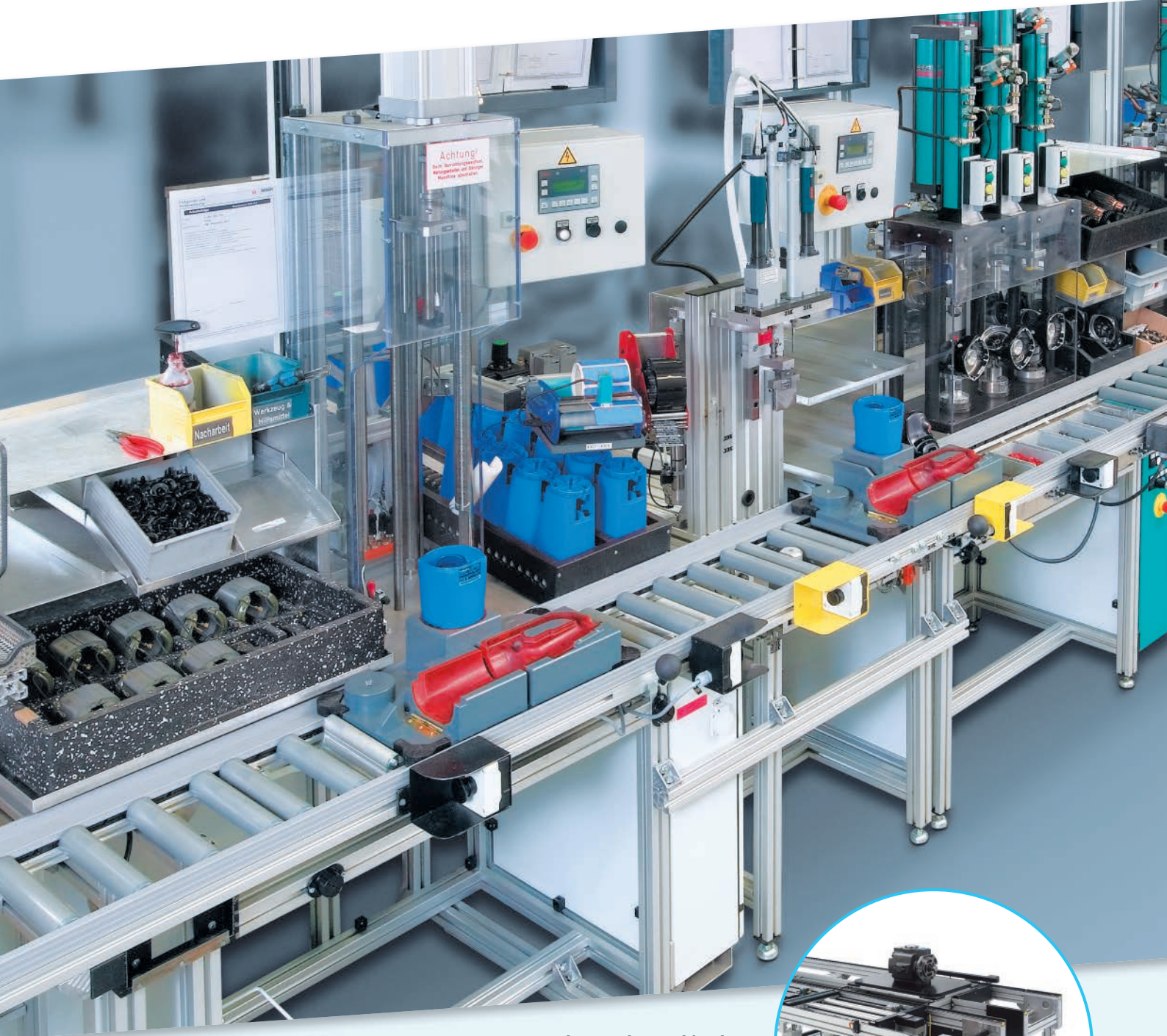
You can procure these conveyor tracks either fully assembled or as single components for self-assembly. A range of conveyor media allows you to adapt the conveyor tracks in an ideal way to your goods: Cardboard boxes and blister packs are carried on full-width plastic or steel rollers, or you may choose to use slide sections. Its high level of stability also makes EcoFlow ideal for transporting heavy loads.

To complete your system, you may add accessories such as stop gates for positioning materials at the workstation, or ball rollers for creating branch-offs and curves. All EcoFlow components are designed for use in combination with the products in Rexroth's MPS and MGE programs.

The system is fully ESD-compatible and may be used in ESD-sensitive areas.

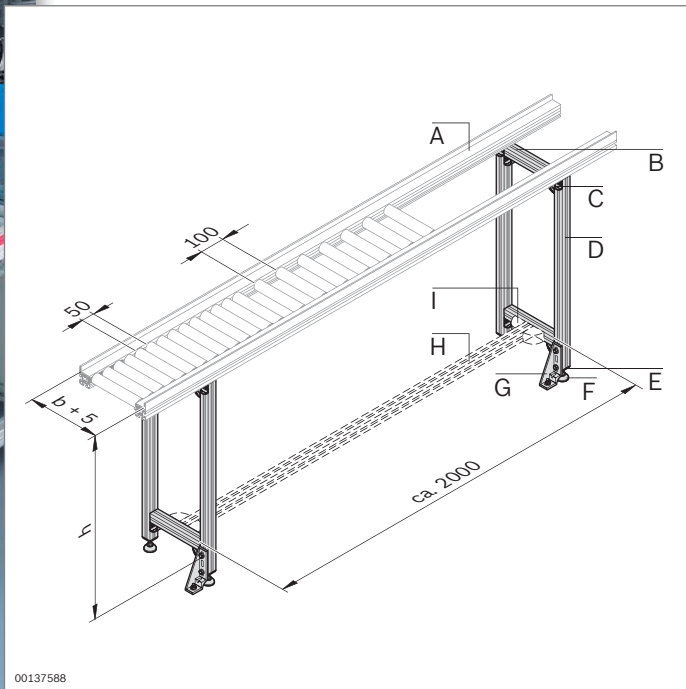


# EcoFlow Application examples



► EcoFlow can be combined with Rexroth's power-driven transfer systems. For more information, visit [www.boschrexroth.com](http://www.boschrexroth.com)

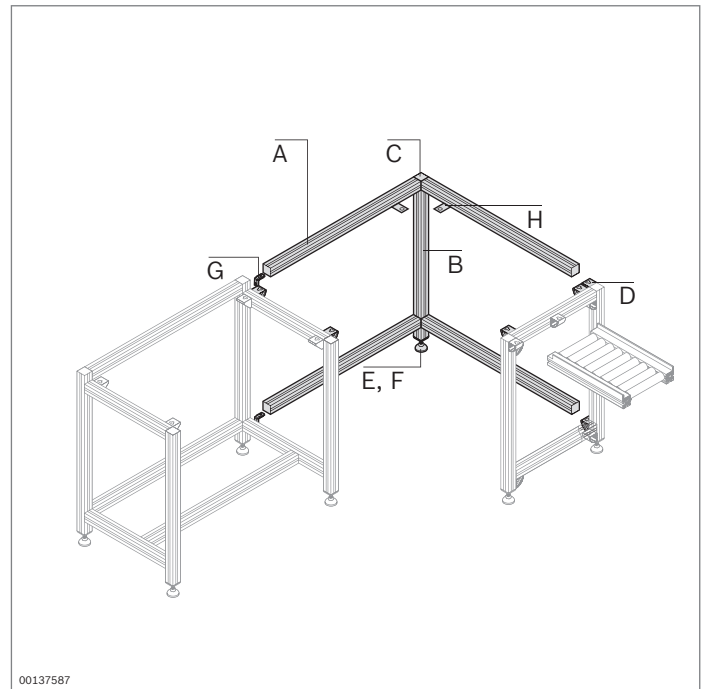


**Application 1: Manual slide section**

00137588

Application 1	No.
<b>A</b> 1 x EcoFlow conveyor track with stop plate	<b>3 842 998 278</b>
<b>B</b> 4 x 45x45L strut profile	<b>3 842 993 737</b>
<b>C</b> 12 x 45x45 bracket	<b>3 842 523 561</b>
<b>D</b> 4 x 45x45L strut profile	<b>3 842 993 737</b>
<b>E</b> 4 x 45x5 cover cap (with hole)	<b>3 842 548 797</b>
<b>F</b> 4 x Leveling foot	<b>3 842 352 061</b>
<b>G</b> 2 x 45x180 bracket	<b>3 842 523 583</b>
<b>H</b> 1 x 45x45L strut profile	<b>3 842 993 737</b>
<b>I</b> 4 x 45x45 bracket	<b>3 842 523 561</b>

▲ **Build frames for roller section or manual slide section using Rexroth strut profiles and connectors.**

**Application 2: Corner frame**

00137587

Application 2	No.
<b>A</b> 4 x 45x45L strut profile	<b>3 842 993 737</b>
<b>B</b> 1 x 45x45L strut profile	<b>3 842 993 737</b>
<b>C</b> 1 x 45x45 cover cap	<b>3 842 548 753</b>
<b>D</b> 6 x 45x45 bracket	<b>3 842 523 561</b>
<b>E</b> 1 x 45x45 cover cap (with hole)	<b>3 842 548 797</b>
<b>F</b> 1 x Leveling foot	<b>3 842 352 061</b>
<b>G</b> 6 x Inner bracket	<b>3 842 535 571</b>
<b>H</b> 1 x Table top supports (set)	<b>3 842 521 677</b>

7

**MTpro**

For simple and efficient planning, we recommend using **MTpro**. For detailed information, see pages 1-9/10 or [www.boschrexroth.com](http://www.boschrexroth.com)



00139096

### EcoFlow conveyor track

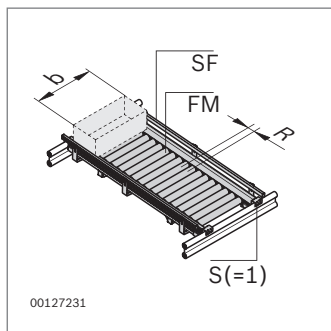


- ▶ For supplying materials to workstations and in flow rack systems
- ▶ For the manual linking of workstations
- ▶ Aluminum profile conveyor track
- ▶ Full-width rollers available in plastic, steel or stainless steel
- ▶ Recommended conveyor track width:  $BF = \text{container width } b + 5 \text{ mm}$
- ▶ Rail holders for suspending on tubular cross tie: Preferably used in flow rack systems or at workstations for supplying materials in the accessory upright
- ▶ Stop plates suitable for the manual linking of workstations
- ▶ Save money by choosing the larger roller distance  $R$
- ▶ Steel conveyor medium available in ESD-conductive version

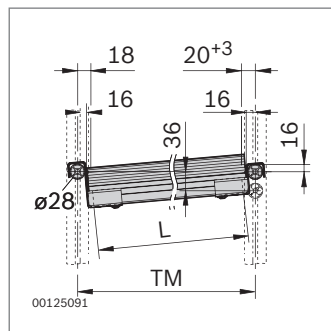
Condition on delivery: Sliding rail border mounted to the outside ( $BG=0$ )



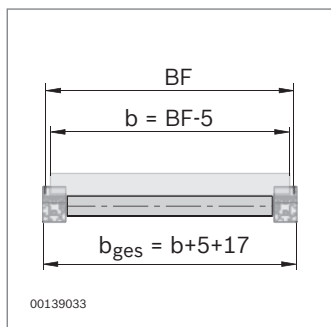
00137604



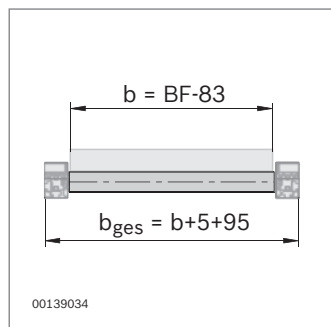
00127231



00125091

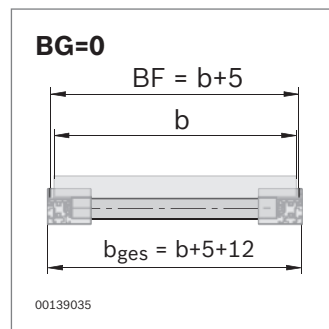
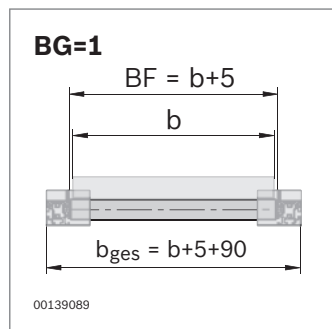
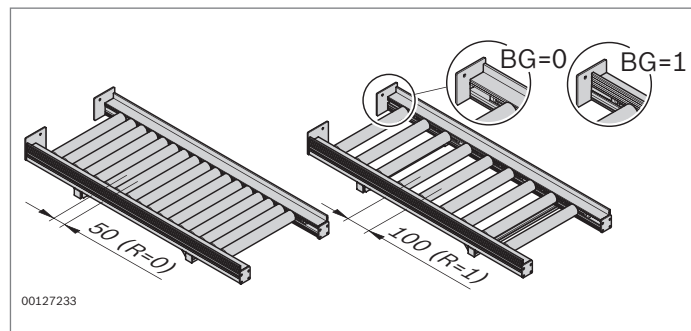
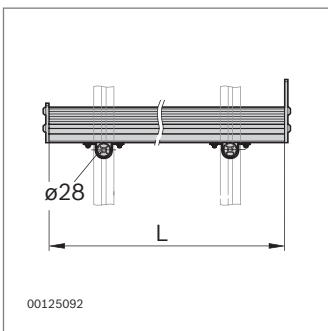
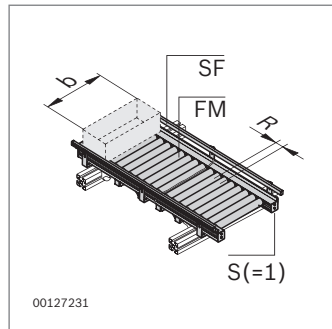


00139033



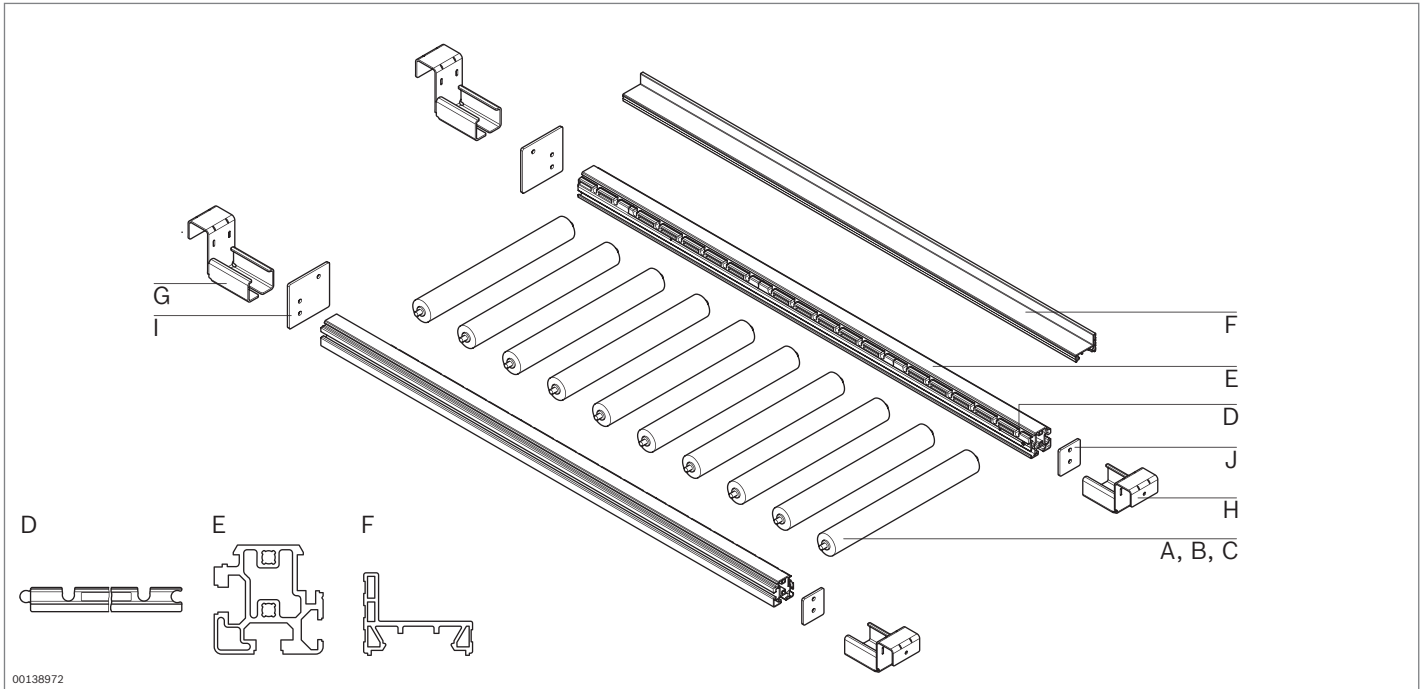
00139034











Conveyor track with rail holders		3842998258
<b>A</b>	Version	Yes/no
<b>ESD</b>	Conductivity	400 ... 1020 mm
<b>TM</b>	Horizontal distance between tubular cross ties	300 ... 600 mm
	max. distance when A is mounted	3000 mm
<b>G</b>	Gradient	0 ... 10 % (recommended: 6 %)
<b>FM</b>	Conveyor medium	Rollers in plastic, steel, stainless steel
<b>BF</b>	Conveyor track width	200 ... 1000 mm
<b>S</b>	Rail holder design	With stop, without stop
<b>SF</b>	Lateral guide	With, without
<b>R</b>	Roller distance	50, 100 mm

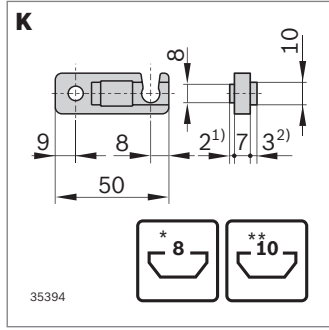
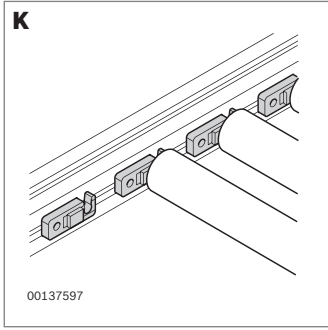


<b>Conveyor track with stop plates</b>		<b>3842998278</b>
<b>A</b>	Version	Disassembled, assembled
<b>ESD</b>	Conductivity	Yes, no
<b>L</b>	Conveyor track length	355 ... 6000 mm
	max. length when A is mounted	3000 mm
<b>FM</b>	Conveyor medium	Rollers in plastic, steel, stainless steel
<b>BF</b>	Conveyor track width	200 ... 1000 mm
<b>S</b>	Stop plate version	With stop, without stop
<b>SF</b>	Lateral guide	With, without
<b>R</b>	Roller distance	50, 100 mm
<b>BG</b>	Slide rail border	Inside, outside





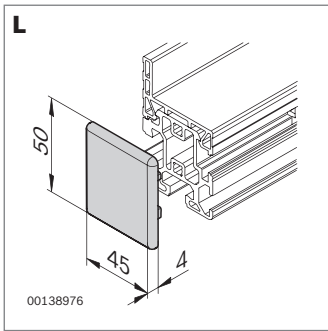
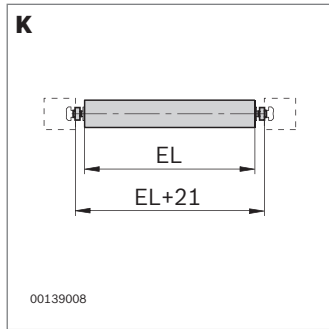
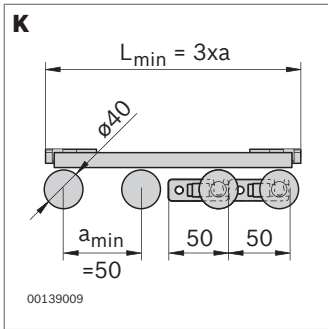
	<b>F (N)</b>	<b>EL (mm)</b>			<b>ESD No.</b>
<b>A</b> EcoFlow roller – plastic	150	105 ... 605			<b>3 842 994 989/L</b>
		225			<b>3 842 525 740</b>
		325			<b>3 842 525 741</b>
		425			<b>3 842 525 742</b>
		525			<b>3 842 537 164</b>
<b>B</b> EcoFlow roller – steel, galvanized	500	105 ... 1005			<b>3 842 994 988/L</b>
		225			<b>3 842 525 737</b>
		325			<b>3 842 525 738</b>
		425			<b>3 842 525 739</b>
		525			<b>3 842 537 163</b>
<b>C</b> EcoFlow roller – stainless steel	150	105 ... 1005			<b>3 842 995 008/L</b>
<b>D</b> EcoFlow roller carrier				10	 <b>3 842 535 683</b>
<b>E</b> EcoFlow section profile		70 ... 6070	1		<b>3 842 993 029/L</b>
		6070	20		<b>3 842 537 321</b>
<b>F</b> MV45 guide profile		70 ... 3000	1		<b>3 842 996 432</b>
		3000	10		<b>3 842 554 758</b>
		70 ... 3000	1		<b>3 842 993 512/L</b>
		3000	10		<b>3 842 526 034</b>
<b>G</b> Rail holder with stop				20	<b>3 842 537 664</b>
<b>H</b> Rail holder without stop				20	<b>3 842 537 665</b>
<b>I</b> Stop plate with stop				20	<b>3 842 537 593</b>
<b>J</b> Stop plate without stop				20	<b>3 842 537 592</b>



**Roller fixation (K)**

- For fast and simple construction of conveyor tracks using strut profiles with 8 or 10 mm slot. Can also be used in the 10 mm slot of the EcoFlow section profile
- Suitable for retrofitting rollers without having to disassemble the frame. The roller distance is variable


Scope of delivery: Includes fastening material for 8 or 10 mm slot

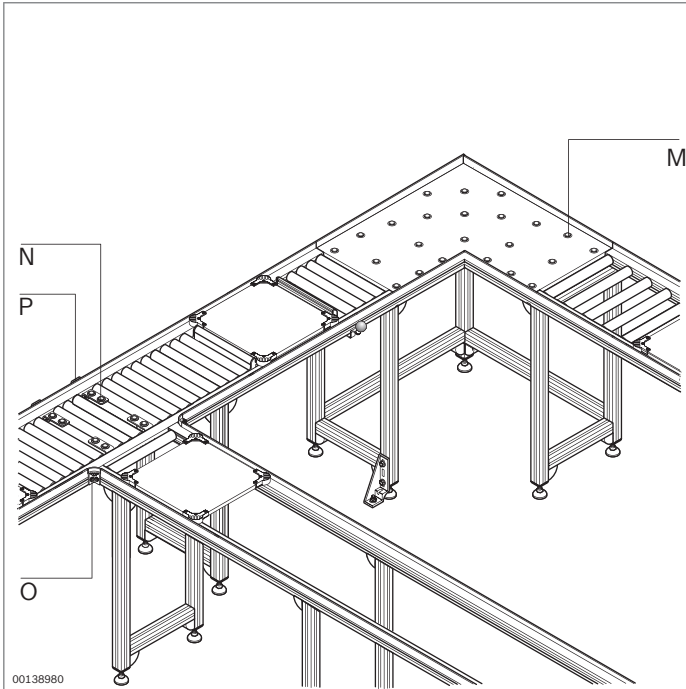


**Cover cap (L)**

- Cover cap for EcoFlow section profile with guide profile

Material: PA6, black

		No.
<b>K</b> Roller fixation, 8 mm slot	10	<b>3 842 535 667</b>
Roller fixation, 10 mm slot	10	<b>3 842 535 668</b>
<b>L</b> Cover cap	20	<b>3 842 525 457</b>

**Ball roller (M)**

- For creating branch-offs or curves

Material: Steel housing, galvanized; stainless steel ball

**Transverse conveyor (N)**

- For connecting EcoFlow secondary sections

Material: Steel housing, galvanized; stainless steel ball

**Corner piece (O)**

- For fixing EcoFlow secondary sections at same level

Material: PA; black, ESD-conductive

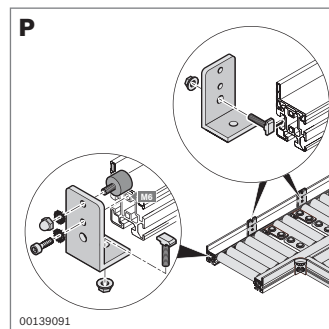
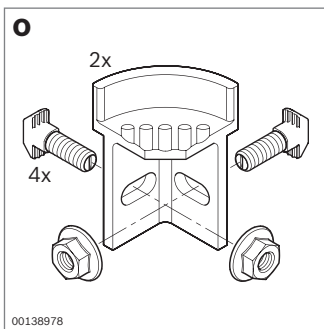
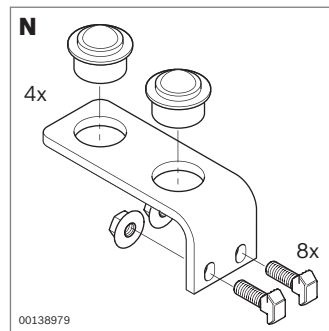
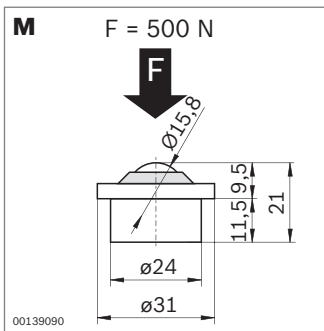
**Stop (P)**





- For gently stopping the workpiece pallet.

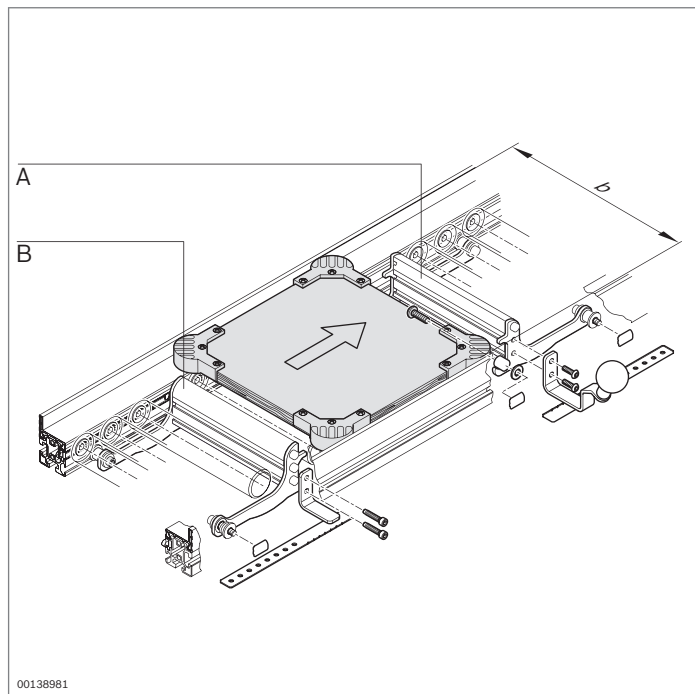
Fastened to EcoFlow section profiles or strut profiles with 10 mm slot

Material: Aluminum; anodized

Scope of delivery: Includes fastening material for 10 mm slot



		ESD No.
<b>M</b> Ball roller	20 	<b>3 842 541 008</b>
<b>N</b> Transverse conveyor	Set 	<b>3 842 536 055</b>
<b>O</b> Corner piece	Set 	<b>3 842 536 056</b>
<b>P</b> Stop	Set	<b>3 842 536 057</b>



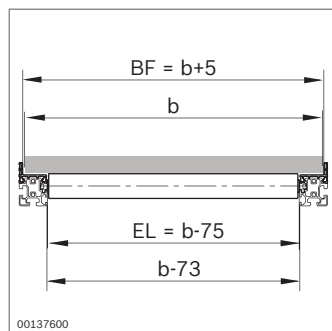
00138981

### EcoFlow stop gates and return stops

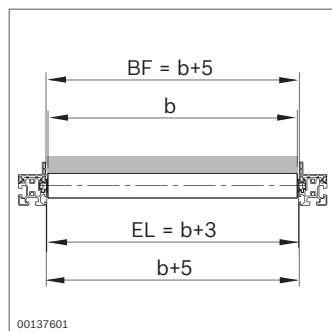


- ▶ Stop gate and return stop for positioning workpiece pallets or containers
- ▶ At the planning stage remember to leave sufficient leg room. The stop gate and return stop extend downwards by an additional 45 mm
- ▶ We recommend using a workpiece pallet with corner pieces (page 7-12) to provide a defined stopping mechanism

Condition on delivery: Sliding rail border mounted to the outside (BG=0)

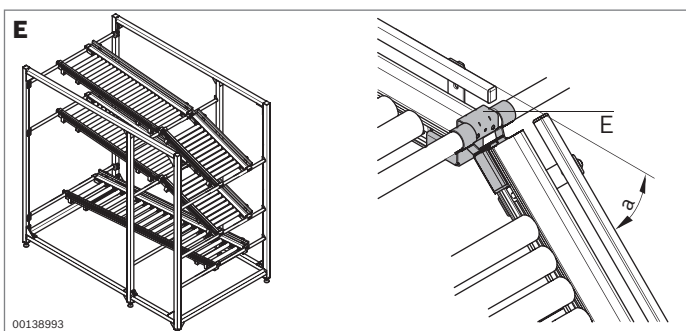
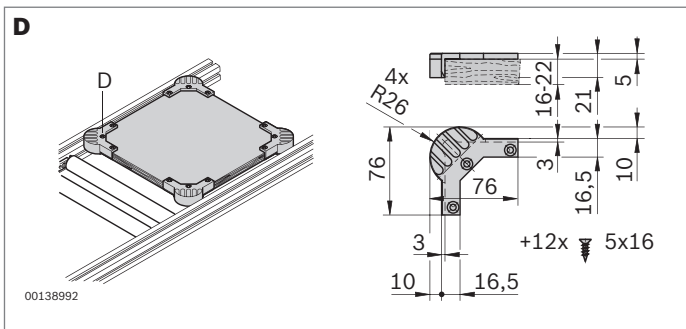
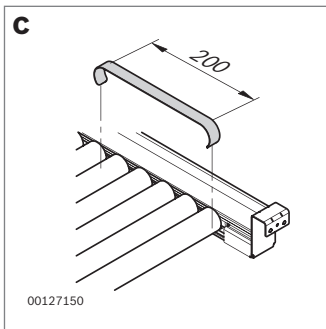
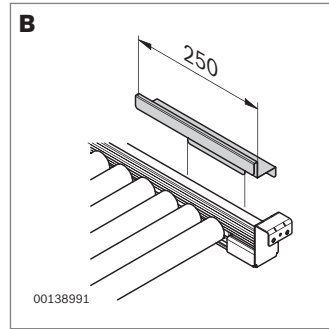
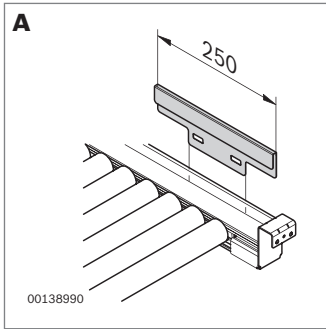


00137600



00137601

	EL (mm)	No.
<b>A</b> Stop gate	105 ... 1005	<b>3 842 995 007/EL</b>
	225	<b>3 842 537 894</b>
	325	<b>3 842 537 895</b>
	425	<b>3 842 537 896</b>
	525	<b>3 842 537 897</b>
<b>B</b> Return stop	105 ... 1005	<b>3 842 995 017/EL</b>
	225	<b>3 842 537 898</b>
	325	<b>3 842 537 899</b>
	425	<b>3 842 537 900</b>
	525	<b>3 842 537 901</b>



## EcoFlow accessories

### Protective cover (A, B)

- ▶ Protective cover to shield the EcoFlow guide profile when loading the conveyor track. Select cover for border outside (BG = 0) or border inside (BG = 1)

Material: Steel, galvanized

Scope of delivery: 2 protective covers incl. fastening material

### Brake (C)

- ▶ Brake for bringing containers to a stop gently

Material: Steel, galvanized

### Corner pieces (D)

- ▶ Corner pieces for self-assembly of workpiece pallets
- ▶ For isolating parts from the pallet queue, well-defined guidance and stopping surfaces, good transition through curves and avoidance of edges where trapping may occur

Material: PA, ESD


Scope of delivery: 4 corner pieces incl. fastening material

### Flexible bridge (E)

- ▶ Flexible bridge for easy material supply in the flow rack system. The container is stopped by a rail holder with stop and is moved manually to the inclined position
  - $a_{\max} = 40^\circ$  (tubular cross tie)
  - $a_{\max} = 30^\circ$  (double tubular cross tie)

Material: Steel, galvanized

Scope of delivery: Incl fastening material

	ESD	No.
<b>A</b> Protective covers – outside slide rail (BG = 0)	Set	<b>3 842 537 583</b>
<b>B</b> Protective covers – inside slide rail (BG = 1)	Set	<b>3 842 537 584</b>
<b>C</b> Brake	20	<b>3 842 537 740</b>
<b>D</b> Corner pieces for workpiece pallets	Set 	<b>3 842 536 054</b>
<b>E</b> Flexible bridge	20	<b>3 842 537 950</b>



# Systematic supply in production

**Standardized material supply in production using defined delivery areas creates clarity and minimizes stocks while simultaneously increasing transparency. This reduces tied up capital and expedites parts to workers by eliminating search times.**

## Material shuttles

The use of material shuttles at workstations is particularly beneficial for workstations that deal with a high degree of variance; they are the alternative to fixed-installation material supply systems.

Prefabricated material shuttles can be replaced quickly and easily. This cuts the waste that occurs in the form of waiting and conversion times. The Logistics material shuttle is used to link the supermarket with the workstation and to pick the materials needed at a workstation or for a work step. You can order material shuttles as a complete system with variable dimensions and equipment or as a standard material shuttle. You can also procure individual components to assemble special constructions to meet your specific requirements.

## FiFo station

Complying with the FiFo principle facilitates simple traceability in the case of material faults or disruptions in the process. The FiFo station can be compared to a supermarket for dollies, material shuttles and commissioning shuttles. The supermarket's size can be adjusted easily and quickly to your individual needs through the modular construction of the rail system. The FiFo station supports the 5S principles for material supply.

## OVERVIEW OF MATERIAL SHUTTLES

- 8-3** Workstation material shuttles
- 8-5** Logistics material shuttles
- 8-9** FiFo station





## Workstation material shuttles



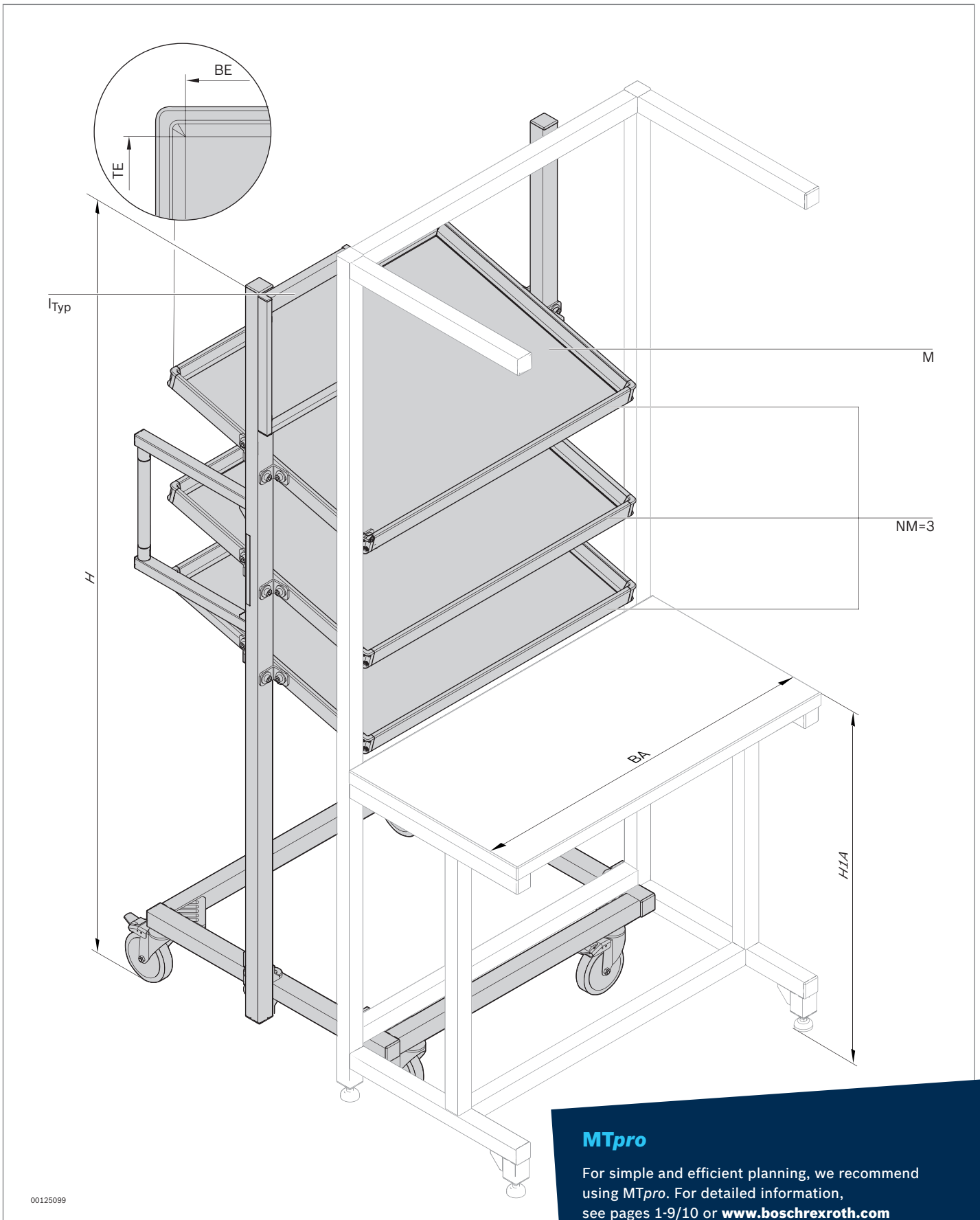
- ▶ Parts positioned within grab area of workstation
- ▶ Short conversion times with quick exchange of pre-picked material shuttles
- ▶ Can be equipped and sized to meet specific requirements
- ▶ Available as ESD-conductive version
- ▶ Version: Fully assembled or as a kit for self-assembly
- ▶ Optional information board for supplying information directly at location
- ▶ Adjustable material shelf height, offset, and tilt to ensure ergonomic grabbing
- ▶ Basic material shelves (pages 2-17, 12-5/6) incl. labeling clip; various plates available
- ▶ Castor wheels: Ball bearing, with locking mechanism
- ▶ Can be used in combination with workstation (page 2-13) or for supplying materials in conjunction with the manual linking system EcoFlow

### Accessories:

Rubber profile to protect against heavy impacts when positioning the material shuttle (page 2-19),  
swivel mounting for tilting the material shelf (page 12-4)

See technical data  
page 13-21 f.

Workstation material shuttle		3 842 998 231
<b>A</b>	Version	Disassembled, assembled
<b>ESD</b>	Conductivity	Yes, no
<b>H</b>	Material shuttle height	600 ... 2200 mm
<b>H1A</b>	Work surface height	410 ... 1500 mm
<b>NM</b>	Number of material shelves (Basic)	0 ... 4
<b>M</b>	Material shelf material	3 different surface materials
<b>BE</b>	Material shelf width	250 ... 1480 mm
<b>TE</b>	Material shelf depth	410 ... 1220 mm
<b>I<sub>typ</sub></b>	Information board	7 different information boards



00125099

**MTpro**

For simple and efficient planning, we recommend using MTpro. For detailed information, see pages 1-9/10 or [www.boschrexroth.com](http://www.boschrexroth.com)



## Logistics material shuttles

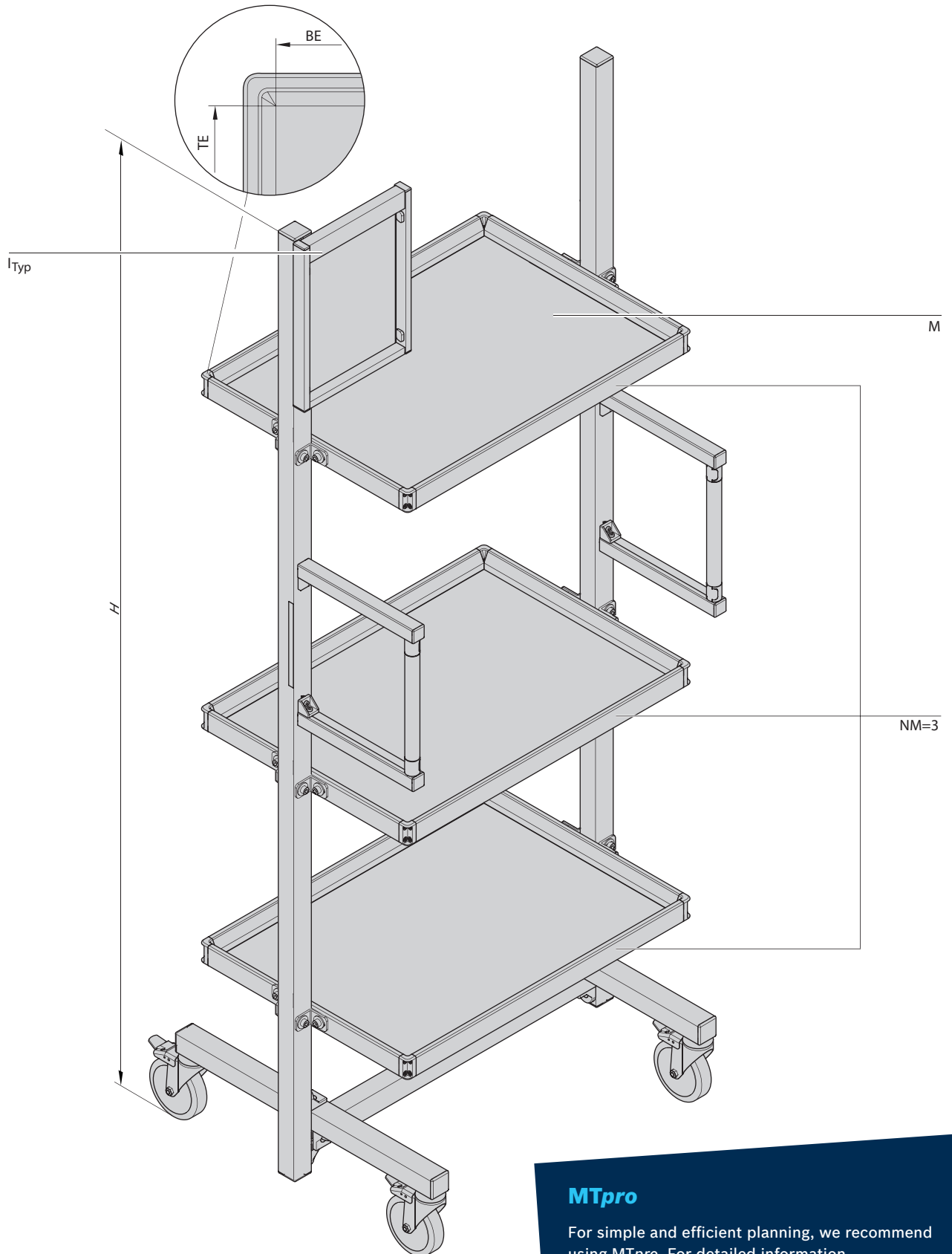


- ▶ C-parts supply on side of workstation
- ▶ Manual linking of two workstations or of supermarket shelves with workstations and production islands
- ▶ Can be equipped and sized to meet specific requirements
- ▶ Available as ESD-conductive version
- ▶ Version: Fully assembled or as a kit for self-assembly
- ▶ Optional information board for supplying information directly at location
- ▶ Adjustable material shelf height, offset, and tilt to ensure ergonomic grabbing
- ▶ Basic material shelves (pages 2-17, 12-5/6) incl. labeling clip; various plates available
- ▶ Castor wheels: Ball bearing, with locking mechanism

Accessories: Swivel mounting for tilting the material shelf (page 12-5)

See technical data  
page 13-21 f.

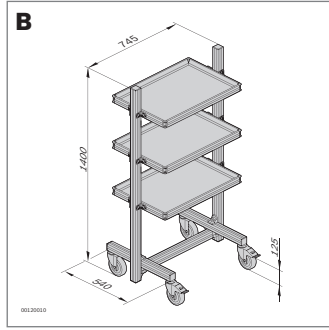
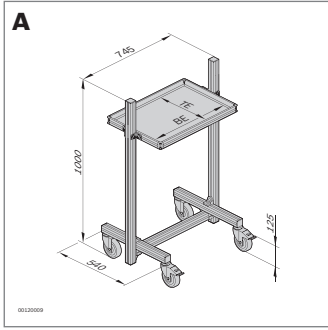
Basic logistics material shuttle		3 842 998 230
<b>A</b>	Version	Disassembled, assembled
<b>ESD</b>	Conductivity	Yes, no
<b>H</b>	Material shuttle height	600 ... 2200 mm
<b>NM</b>	Number of material shelves (Basic)	0 ... 4
<b>M</b>	Material shelf material	3 different surface materials
<b>BE</b>	Material shelf width	410 ... 1480 mm
<b>TE</b>	Material shelf depth	410 ... 1220 mm
<b>I<sub>typ</sub></b>	Information board	7 different information boards



00109298

**MTpro**

For simple and efficient planning, we recommend using MTpro. For detailed information, see pages 1-9/10 or [www.boschrexroth.com](http://www.boschrexroth.com)



### Standard logistics material shuttle

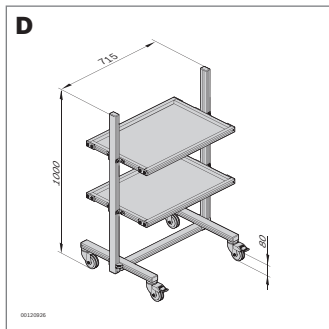
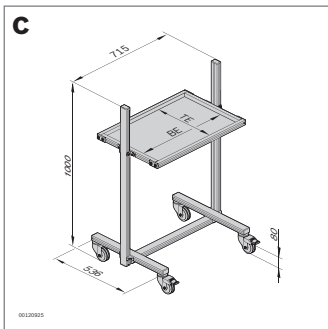


#### Basic

- ▶ For heavy-duty use in transport and material supply
- ▶ Adjustable material shelf height, offset, and tilt to ensure ergonomic grabbing
- ▶ Available as ESD-conductive version
- ▶ Basic material shelves (pages 2-17, 12-5/6), plate: PP, SB (ESD)
- ▶ Castor wheels: Ball bearing, with locking mechanism

Accessories: Material shelf (pages 2-17, 12-5/6), labeling clip (pages 2-18, 12-5/6), swivel mounting for tilting the material shelf (pages 12-5/6)

Basic logistics material shuttle		H (mm)	B <sub>E</sub> (mm)	T <sub>E</sub> (mm)	ESD	No.
A	1 shelf	1000	610	410		<b>3 842 515 483</b>
		1000	610	410		<b>3 842 515 484</b>
B	3 shelves	1400	610	410		<b>3 842 508 181</b>
		1400	610	410		<b>3 842 508 182</b>

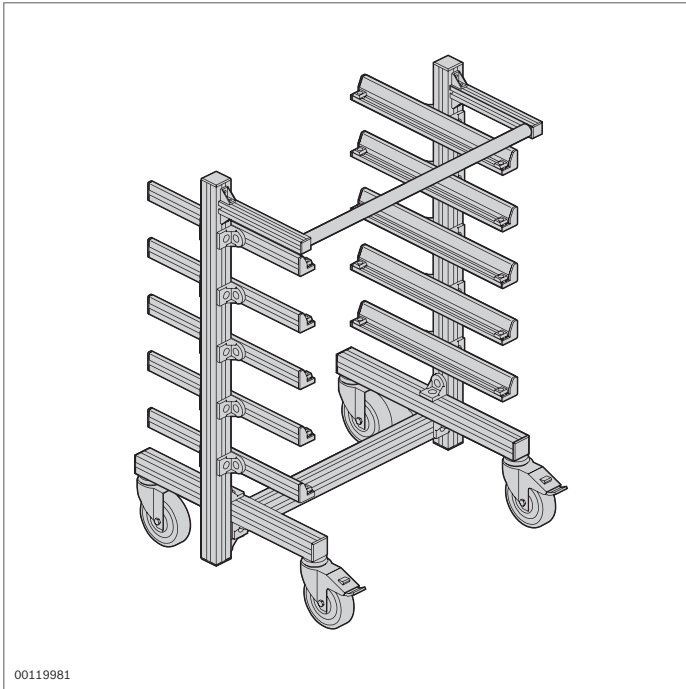


#### Economic

- ▶ For medium-duty applications
- ▶ Adjustable material shelf height, offset, and tilt to ensure ergonomic grabbing
- ▶ Available as ESD-conductive version
- ▶ Economic material shelves (pages 2-17, 12-3/4), plate: PP, SB (ESD)
- ▶ Castor wheels: Rubber tires, with locking mechanism

Accessories: Material shelf (pages 2-17, 12-3/4), labeling clip (pages 2-17, 12-3/4), swivel mounting for tilting the material shelf (page 12-3/4)

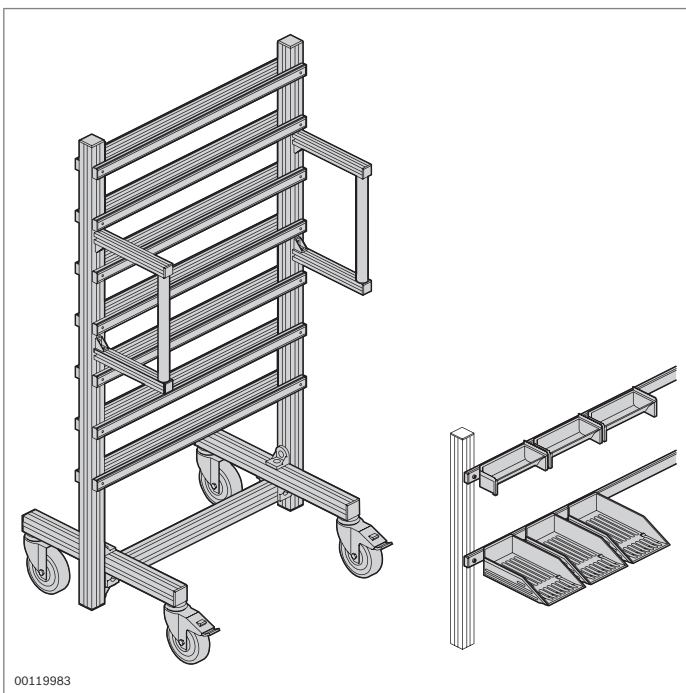
Economic logistics material shuttle		H (mm)	B <sub>E</sub> (mm)	T <sub>E</sub> (mm)	ESD	No.
C	1 shelf	1000	610	410		<b>3 842 515 481</b>
		1000	610	410		<b>3 842 518 120</b>
D	2 shelves	1000	610	410		<b>3 842 515 482</b>
		1000	610	410		<b>3 842 518 121</b>



## Applications

### Material shuttle with angle profile

- ▶ To hold workpiece pallets and containers, including small parts containers



### Material shuttle with suspension profile

- ▶ To hold grab containers for commissioning, transport and supply of small parts

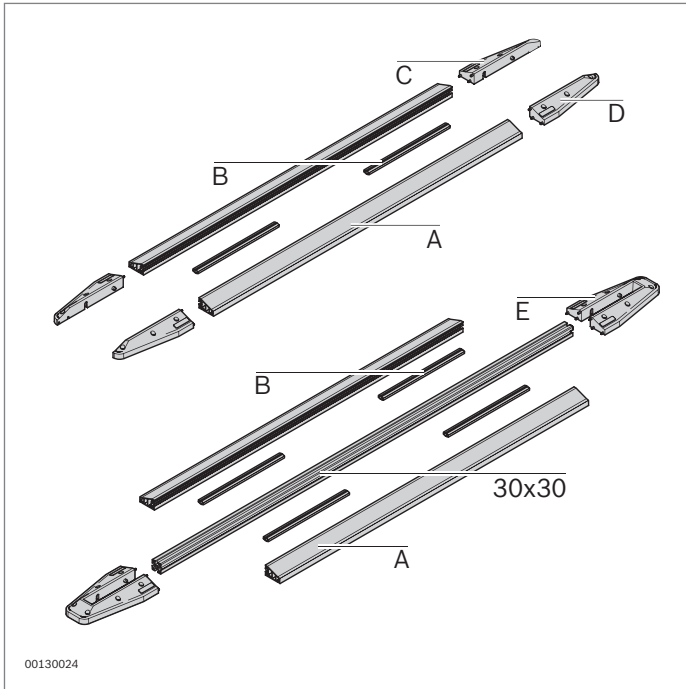
Further material shuttle variants can be custom-built to meet specific requirements. The individual components are described in the "Components" section (page 12-1).



00137599

## FiFo station

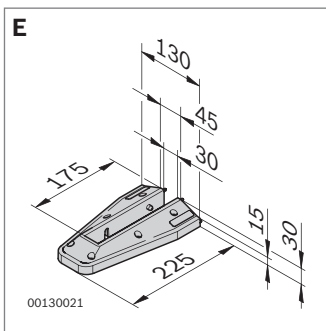
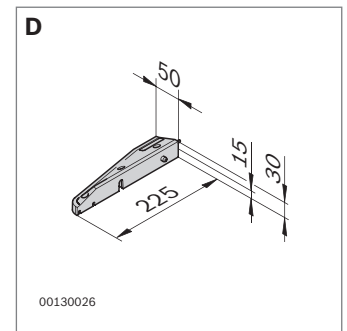
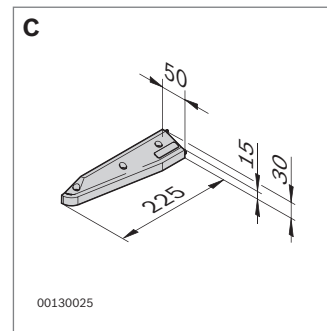
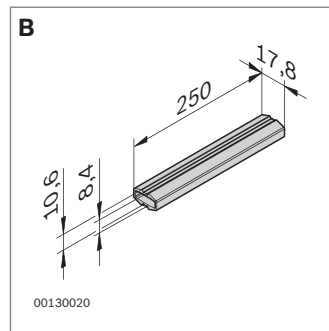
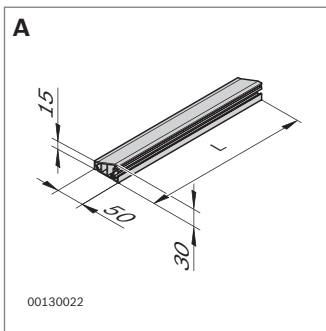
- ▶ Clearly organized and highly transparent production operations through having standardized delivery routes
- ▶ Clear visualization to help minimize stocks
- ▶ Implementation of the Kanban principle
- ▶ Structured material supply system with efficient, well-defined processes to help find required materials fast
- ▶ Easy tracing of faults and malfunctions through observation of the FiFo principle
- ▶ Modular system lets you adapt the layout to your needs and to your available space
- ▶ Flow rack systems can be integrated to save space. The flow rack is set up on the FiFo tracks, light parts are stored in the flow rack and heavy parts on dollies or material shuttles in the FiFo station.
- ▶ Information supplied by attaching information boards
- ▶ A transverse profile can be installed to set a height limit for materials



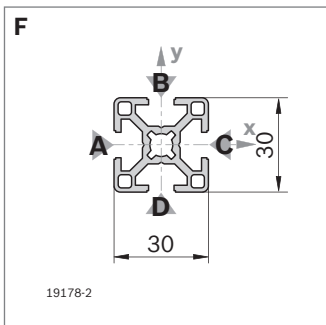
### Components

- ▶ Guide rail fastened to floor using adhesive strips, end caps may also be screwed in place (if required)
- ▶ Adapter for connecting two guide rails, or a guide rail with a 30x30 profile
- ▶ Large end caps for integrating a 30x30 profile for use in installing flow rack systems, information boards and height limits. Since the guide rails are flat-sided, setup can be done using a profile of width 45.

Color: Yellow guide rail, black end cap



	L (mm)			No.
<b>A</b> Guide rail	1200	10		<b>3 842 540 012</b>
	2400	10		<b>3 842 539 894</b>
<b>B</b> Adapter		20		<b>3 842 539 898</b>
<b>C</b> Right end cap, small		10		<b>3 842 539 895</b>
<b>D</b> Left end cap, small		10		<b>3 842 539 896</b>
<b>E</b> End cap, large		10		<b>3 842 539 897</b>
<b>F</b> 30x30 profile	50 ... 6070	1		<b>3 842 993 703/L</b>
	6070	20		<b>3 842 557 206</b>
	6070	1		<b>3 842 557 216</b>





# Case lifters help keep sick days down

**Workstation designers are increasingly aware of the importance of ergonomics on the job. Musculoskeletal disorders are among the primary causes for worker absences. In order to sustainably reduce times absent due to sickness and disability, it is important to minimize the strain placed on workers' bodies.**

Workers who continuously and repetitively lift and lower loads are especially prone to incorrect work posture that can lead to overexertion. Bending of the torso (below 800 mm) places a disproportionate strain on the human body. The electric case lifter literally takes the load off employees' backs by doing the raising and lowering for them. It serves to bring workpieces into the correct grab area or to deliver finished products directly to dollies for further transport. In particular where heavy loads are involved, the case lifter is a great help in supplying materials to the workstation. It can also be positioned at the beginning or end of a conveyor track to feed or remove conveyed items.

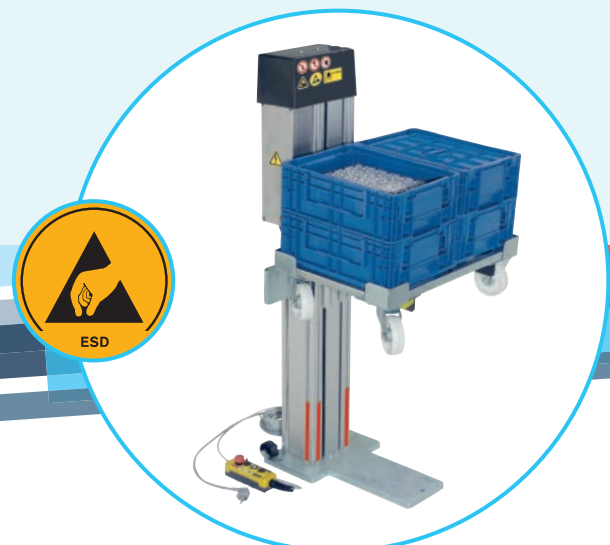
Moreover, it slashes the time required for parts supply and removal by up to 68% (MTM – Method of Time Measurement). Employees can then concentrate their efforts on their value-adding assembly work.

Rexroth's case lifter offers you many advantages, including the following:

- ▶ Compared with manual mode, automatic mode further reduces waiting times
- ▶ In addition to stationary operation, rollers also allow for semi-mobile use
- ▶ Suitable for loads up to 220 kg
- ▶ Space-saving thanks to the compact, closed aluminum housing
- ▶ Suitable for use in ESD-sensitive areas
- ▶ The 10 mm slot enables simple mounting of components from the Basic Mechanic Elements modular system

## CASE LIFTER OVERVIEW

- 9-3 Electric case lifter
- 9-5 Accessories



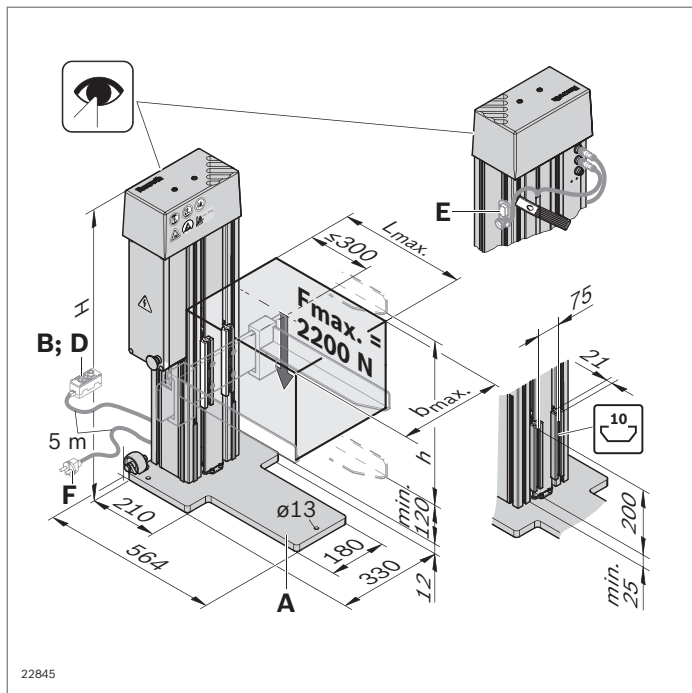


## Electric case lifter

- ▶ Ergonomic parts supply at the workstation
- ▶ Operating mode:
  - Manual: Lifting and lowering through hand switch actuation. Suitable for use with Basic and Comfort hand switches
  - Automatic: Automatic lifting and lowering. Suitable for use with Comfort hand switches in conjunction with Comfort sensor unit (retrofit possible)
- ▶ Rollers for semi-mobile use at various workstations
- ▶ ESD version for use in ESD-sensitive areas
- ▶ The 10 mm slot enables simple mounting of components from the Basic Mechanic Elements modular system
- ▶ Easy start-up; connection via HD mains cable (page 9-4) or connection cable (page 2-40)

Required accessories: Basic hand switch or Comfort hand switch + Comfort sensor unit; mains cable (**F**)

Recommended accessories: Attachment plate, forks, suspension strap (page 9-5)



### Technical data

Permissible load  $F_{max}$ : 2200 N

Lifting velocity: 25 mm/s

Duty cycle (ED): 20 %

Connection: 100–240 V~ / 50–60 Hz / max. 16 A

IP rating: IP 40 IEC 529

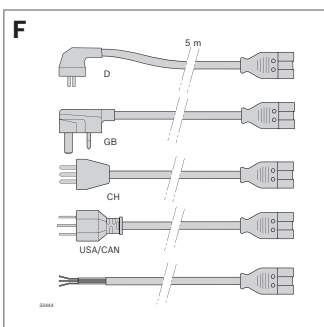
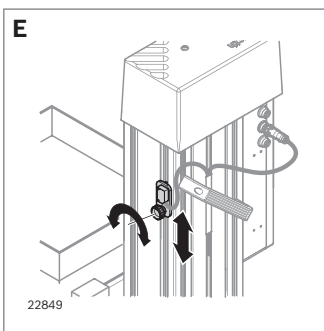
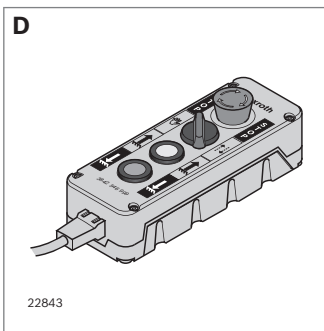
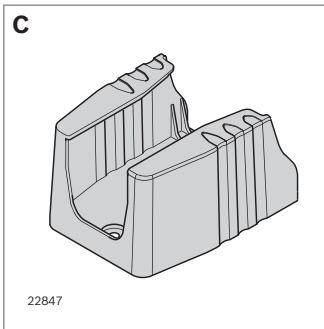
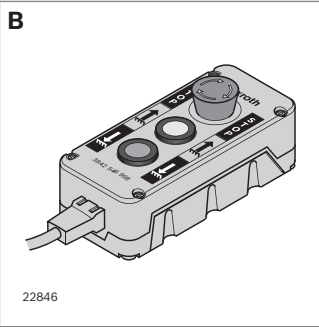
### Max. permitted load bearing surface

Attachment plate width = 450 mm: 400 x 600 mm ( $b_{max}$  x  $L_{max}$ )

Attachment plate width = 650 mm: 600 x 400 mm ( $b_{max}$  x  $L_{max}$ )

		<b>h</b> (mm)	<b>H</b> (mm)	<b>ESD</b>	<b>No.</b>
<b>A</b> Electric case lifter	EU*/USA/CAN	900	1300		<b>3 842 546 992</b>
		1300	1700		<b>3 842 555 641</b>

\*TÜV, UL, and CSA test marks



### Basic hand switch (B)

- ▶ Push button for manual lifting and lowering
- ▶ With emergency stop
- ▶ Can be replaced with Comfort hand switch (D)
- ▶ Not suitable for oily environments, solution on request

	<b>No.</b>
<b>B</b> Basic hand switch	<b>3 842 546 998</b>

### Holder for hand switch (C)

- ▶ To stow Basic and Comfort hand switches

Scope of delivery: Includes fastening material for 10 mm slot

	<b>No.</b>
<b>C</b> Holder for hand switch	<b>3 842 548 038</b>

### Comfort hand switch (D)

- ▶ For selection of "Manual" or "Automatic" mode
- ▶ Push button for manual lifting and lowering in "Manual" mode
- ▶ With emergency stop
- ▶ Not suitable for oily environments, solution on request

	<b>No.</b>
<b>D</b> Comfort hand switch	<b>3 842 546 999</b>

### Comfort sensor unit (E)

- ▶ Works with the Comfort hand switch to control stacking and de-stacking in automatic mode

Scope of delivery: Includes fastening material for 10 mm slot

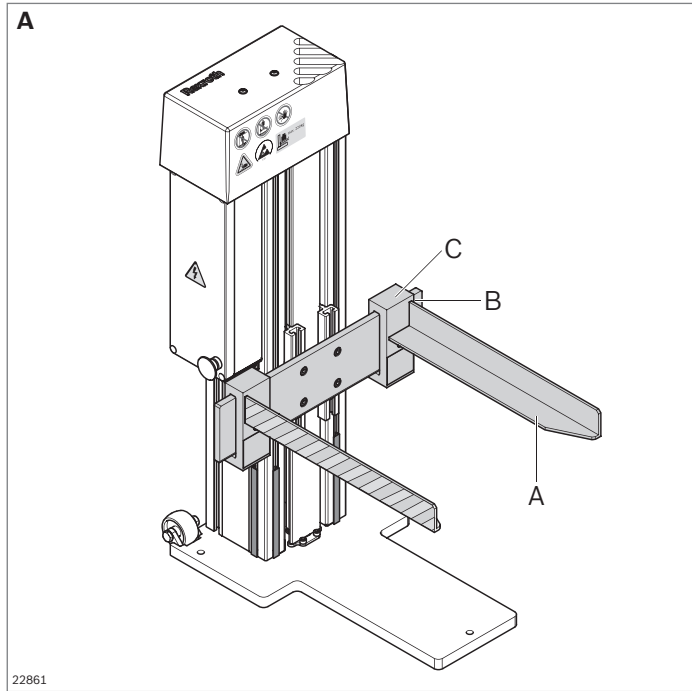
	<b>ESD</b>	<b>No.</b>
<b>E</b> Comfort sensor unit		<b>3 842 547 200</b>

### Mains cable (F)

- ▶ Ready-to-use; for simple, secure plug-and-play installation

		<b>L (m)</b>	<b>No.</b>
<b>F</b> HD mains cable	D/F	5	<b>3 842 554 183</b>
	GB	5	<b>3 842 555 603</b>
	CH	5	<b>3 842 555 605</b>
	Open end	5	<b>3 842 555 607</b>
Mains cable	USA/CAN*	5	<b>3 842 537 323</b>

\*UL and CSA test marks



## Case lifter – accessories

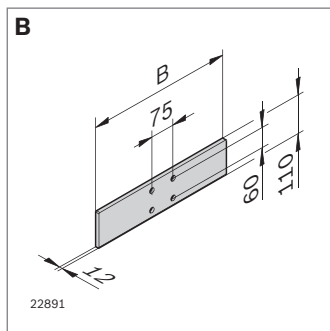
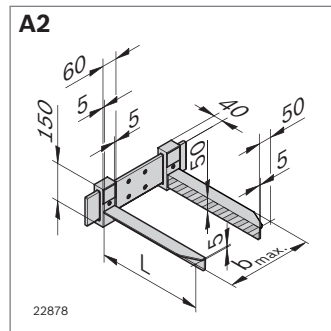
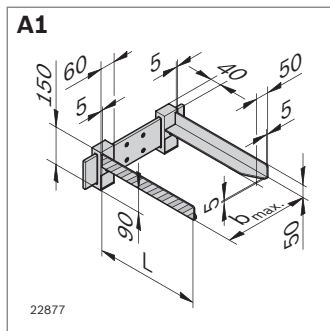
### Forks (A)

- For support of containers (A1) or dollies (A2)

Material: Steel; powder-coated; black, with yellow safety mark on the side

Scope of delivery: Kit with two forks (left and right), incl. fastening material

	L (mm)	ESD	No.
A Forks	400		3 842 549 435
	600		3 842 549 442



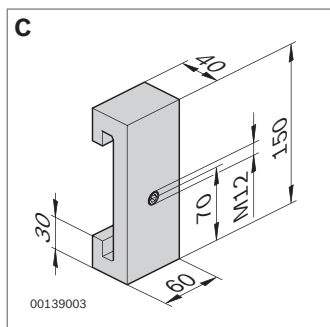
### Attachment plate (B)

- For attaching forks or suspension straps
- Suitable for all case lifters

Material: Steel, galvanized

Scope of delivery: Includes fastening material (with case lifter)

	B (mm)	b <sub>max</sub> (mm)	ESD	No.
B Attachment plate	450	400		3 842 549 427
	650	600		3 842 549 428



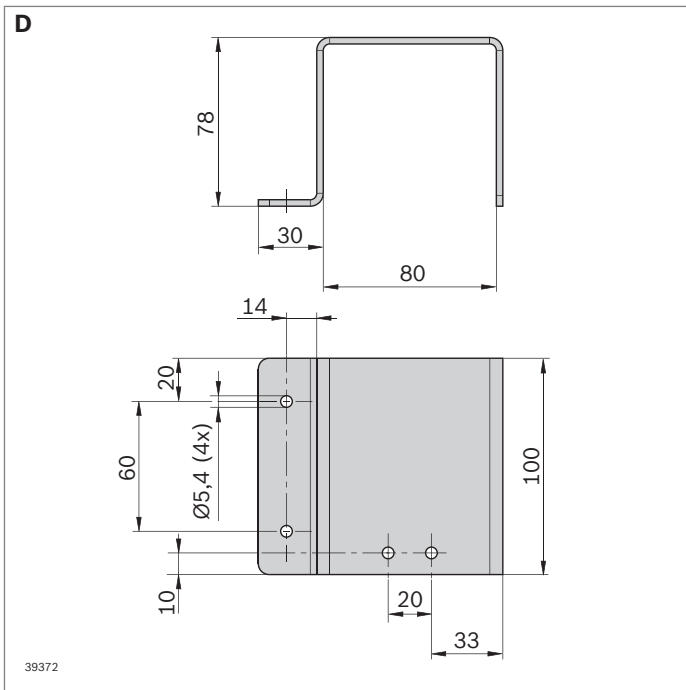
### Suspension strap (C)

- Suitable for attachment plate B
- For attaching individual supports

Material: Steel; preserved

Scope of delivery: Incl fastening material

		ESD	No.
C Suspension strap	Set		3 842 549 449



### Protective sheet (D)

- ▶ Protective sheet for rear of case lifter
- ▶ Additional robust impact protection for plug connections (hand switch and sensor unit)

Material: Aluminum, anodized

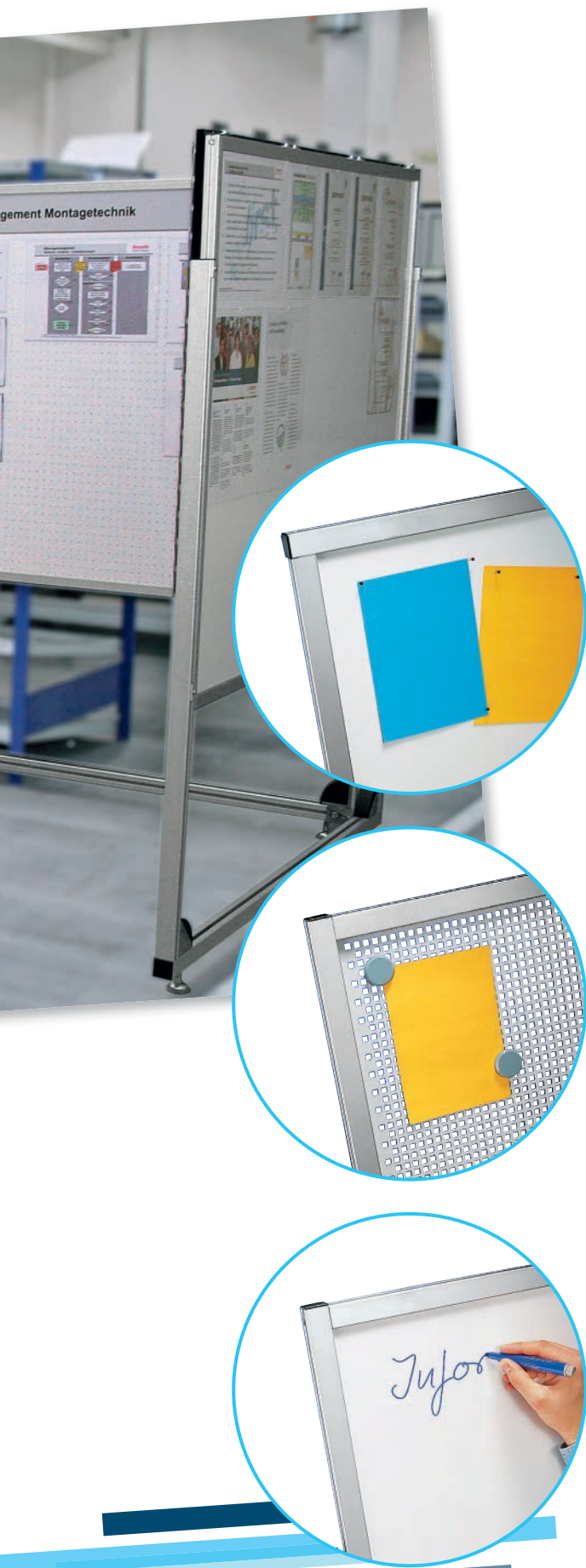
Scope of delivery: Includes fastening material for 10 mm slot

	No.
<b>D</b> Protective sheet	<b>3 842 564 128</b>



# Better employee information for increased transparency and quality

**A key element of lean production is the visual on-site presentation of activities, goals and results. Infoboards can be used to provide important information such as production figures and agreed goals, but also team overviews and job responsibilities within a department. Workers thus have access to information on-site and at any time.**

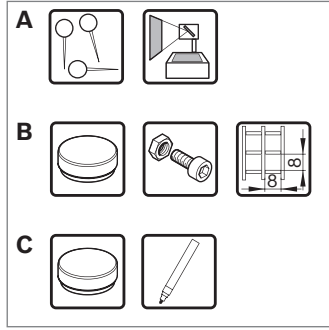


The infoboards are fully suitable for industrial use due to their stable, robust construction. There are three versions available:

- ▶ For pins, can be used as a projection screen
- ▶ Perforated plate for magnets and screws
- ▶ Magnetic, can be written on both sides for board markers

The boards are made up of modules. The base module is called the Wall infoboard, which becomes the Economic infoboard when the frame is added. The Mobile infoboard has rollers so it can be pushed easily as well as a tilting surface for ergonomic writing.

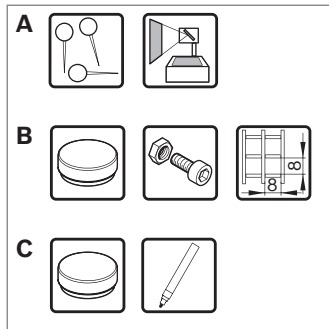
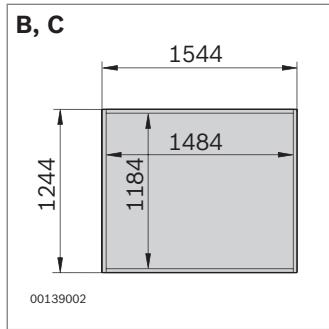
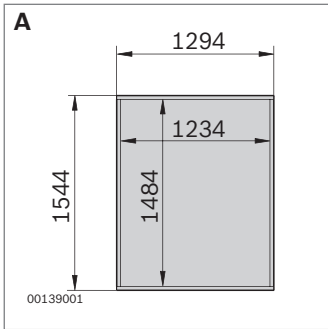
Multiple infoboards can be combined to set up CIP corners and discussion islands.



## Wall infoboard

Accessories: Bracket for wall mounting (page 10-4)

	<b>h x b (mm)</b>	<b>No.</b>
<b>A</b> Wall infoboard – pin	1484 x 1234	<b>3 842 515 775</b>
<b>B</b> Wall infoboard – magnet	1184 x 1484	<b>3 842 516 405</b>
<b>C</b> Wall infoboard – magnet marker	1184 x 1484	<b>3 842 515 776</b>

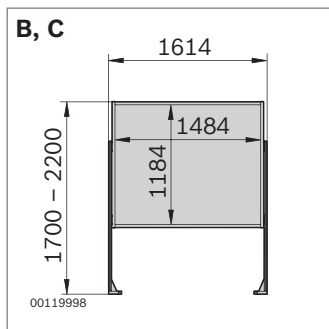
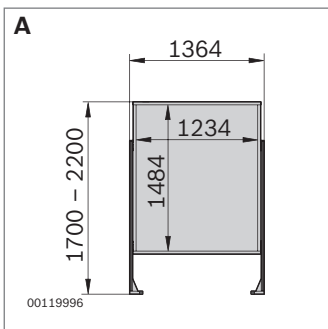


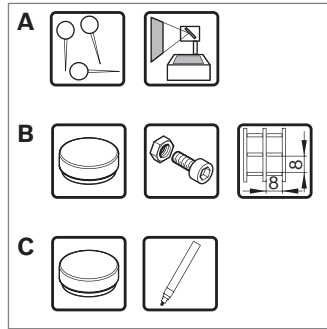
## Economic infoboard

- ▶ Stable frame
- ▶ Can be retrofitted with rollers for mobile applications

Accessories: Roller set (page 10-4)

	<b>h x b (mm)</b>	<b>No.</b>
<b>A</b> Economic infoboard – pin	1484 x 1234	<b>3 842 515 771</b>
<b>B</b> Economic infoboard – magnet	1184 x 1484	<b>3 842 516 406</b>
<b>C</b> Economic infoboard – magnet marker	1184 x 1484	<b>3 842 515 772</b>

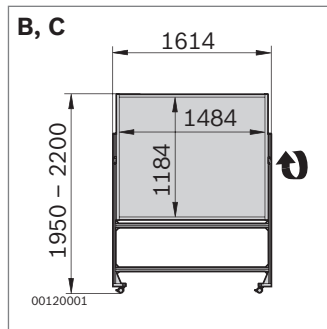
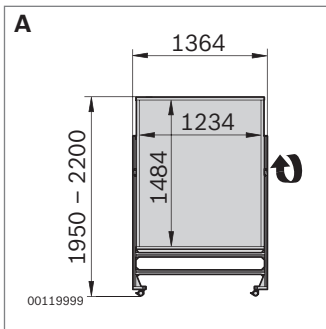




### Mobile infoboard

- ▶ Tilting work surface for good ergonomic posture
- ▶ With locking rollers

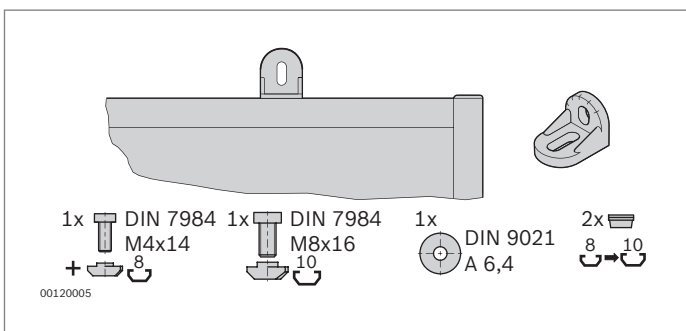
	<b>h x b (mm)</b>	<b>No.</b>
<b>A</b> Mobile infoboard – pin	1484 x 1234	<b>3 842 515 773</b>
<b>B</b> Mobile infoboard – magnet	1184 x 1484	<b>3 842 516 407</b>
<b>C</b> Mobile infoboard – magnet marker	1184 x 1484	<b>3 842 515 774</b>



### Infoboards accessories



	<b>ESD</b>	<b>No.</b>
Roller set for Economic infoboard	4	<b>3 842 535 670</b>
Bracket set for Wall infoboard	1	<b>3 842 515 547</b>



Material: Diecast zinc bracket

Scope of delivery: Set incl. fastening material



## More transparency with ActiveCockpit for optimized production

**Lean production made easy: Even in its basic version, the ActiveCockpit software offers a broad range of options for improving and making manufacturing processes more efficient. All relevant data is processed with transparency and user-friendliness – ideal conditions for rapidly identifying and exploiting optimization potential.**

### **Industry 4.0: Production and IT growing together**

Industry 4.0 is the next major step for manufacturing plants. The dialog between man, machine and product plays an ever-increasing role in technical implementation. The fusion of production IT and company IT, the synchronization of processes and machines that autonomously make decisions in real time all allow for efficient and customized manufacturing.

As the leading supplier of Industry 4.0 solutions, Bosch Rexroth is using its own application experience in production – including for the interactive touchscreens used for the ActiveCockpit industrial software. As a future-oriented software for manufacturing, this solution provides all relevant data directly at the production line.

#### **More work flow efficiency by consolidating information**

A look at a typical manufacturing process shows how many different sources of data workers have to take into account:

Information regarding stock and pending orders can be retrieved from the PC in the production planning department. Status and quality data are documented manually on various boards. Users maintain their personal calendars individually. They also have to be able to operate the user interfaces of the line control and various machines as well as start processes manually.

Via open interfaces ActiveCockpit continuously gathers, processes and filters all the manufacturing data from existing system environments and several data sources.

The latest quality and manufacturing key figures are displayed in real-time on the touchscreen and can be directly analyzed on-site. This gives everyone involved at the plant the most up-to-date information to serve as the basis for improvements and new standards. Deviations from specified production parameters are displayed in the key figures and immediately initiate the improvement process.

## OVERVIEW OF ACTIVECOCKPIT

- 11-5** Software
- 11-7** Extensions
- 11-11** Hardware

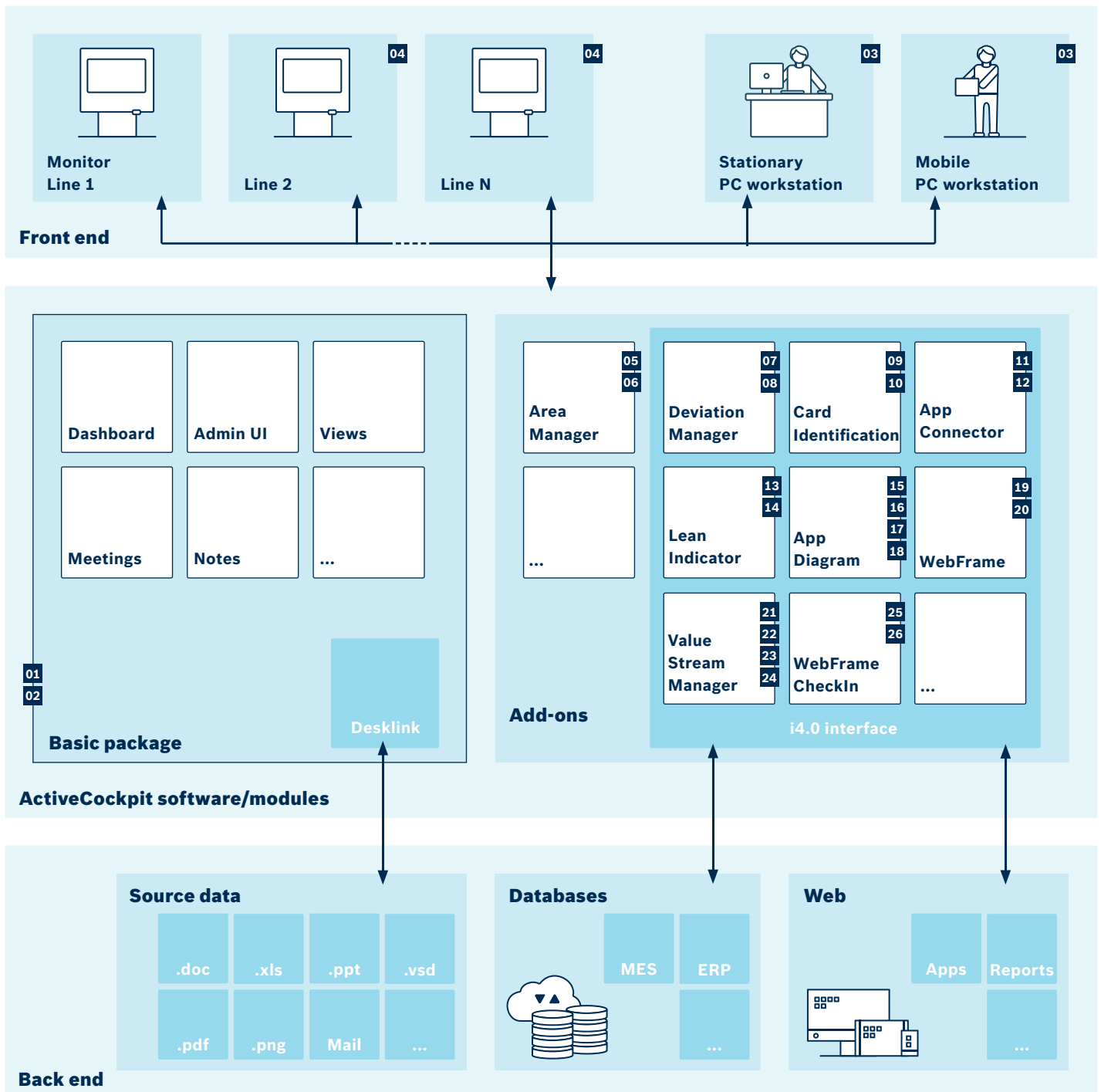


### **Transparent and user-friendly**

The system can at all times display all the data that is relevant for manufacturing – from availabilities and production times to quantities. This not only saves time and money, it also increases productivity and competitiveness.

ActiveCockpit is completely interactive: Whiteboard, escalation, e-mail, notes and up-to-mobile functions help decisions to be made more efficiently.

# ActiveCockpit – system architecture and functions



ActiveCockpit hardware and software			
<b>Software</b>	<b>Basic package</b>	Desklink, meetings, admin UI	
		<b>01 3 842 558 253</b> License for 1st year, including 10 concurrent users, 1 device license	
		<b>02 3 842 558 276</b> License for another 12 months, including 10 concurrent users, 1 device license	
		<b>03 3 842 557 110</b> Yearly license for another 10 concurrent users	
		<b>04 3 842 557 111</b> Yearly license for another device	
<b>Add-ons</b>	<b>Area Manager</b> Optional	Sub-area/area creation, with separate dashboard, administration, user groups and app	
		<b>05 3 842 558 266</b> License for 1st year	
		<b>06 3 844 558 267</b> License for another 12 months	
	<b>DeviationManager</b> Optional	Incident tracking and management with an MES connection	
		<b>07 3 842 558 260</b> License for 1st year (per area)	
	<b>Card Identification</b> Optional	Login to ActiveCockpit by ID card (card reader required)	
		<b>09 3 842 558 273</b> License for 1st year (per card reader)	
	<b>AppConnector</b> Optional	Software developer kit: Use of ActiveCockpit features for internal web applications via interfaces	
		<b>11 3 842 558 264</b> License for 1st year (per area)	
	<b>LeanIndicator</b> Optional	Recording and displaying quality and safety key figures	
		<b>13 3 842 559 888</b> License for 1st year (per area)	
	<b>App Diagram</b> Optional	Display of live data	
		<b>15 3 842 558 256</b> License for 1st year (per area)	
		<b>16 3 842 558 257</b> License for another 12 months (per area)	
		<b>17 3 842 562 624</b> 10 users (license for 1 year)	
	<b>WebFrame</b> Optional	Connection of external web pages/applications	
		<b>19 3 842 558 254</b> License for 1st year (per area)	
	<b>ValueStreamManager</b> Optional	Mapping, design and visualization of value streams	
		<b>21 3 842 562 823</b> License for 1st year (per area)	
		<b>22 3 842 562 824</b> License for another 12 months (per area)	
		<b>23 3 842 563 547</b> 1 device (license for 1 year)	
		<b>24 3 842 563 548</b> 10 users (license for 1 year)	
	<b>WebFrame CheckIn</b> Optional	Deeplink with preview function	
		<b>25 3 842 558 262</b> License for 1st year (per area)	
			<b>26 3 843 558 263</b> License for another 12 months (per area)



# ActiveCockpit – Software Basic package and licenses

## Server and database requirements

- ▶ Operating system: Windows 2012 (or later)
- ▶ CPU: Min. dual-core (quad-core recommended)
- ▶ Memory: Min. 8 GB (16 GB recommended)
- ▶ Hard drive: 2 GB for ActiveCockpit + > 50 GB for data
- ▶ Network connection: Gigabit LAN
- ▶ Software: Microsoft Office 2007 (or later)

## Client requirements

- ▶ Operating system: Windows 7 (or later)
- ▶ Memory: >4 GB
- ▶ CPU: Min. Intel Core i5 3rd generation
- ▶ Software: Microsoft Office 2007 (or later)
- ▶ Network: Tethered Gigabit LAN
- ▶ Graphics card: Ultra HD-capable, e.g.: ATI Radeon 7850 or NVIDIA Geforce GTX 760
- ▶ Cable: 4k-capable HDMI cable

## ActiveCockpit basic package

- ▶ Interactive communications platform for the manufacturing industry
- ▶ Processing and display of manufacturing data in real time
- ▶ Extension of web-based basic software package with applications
- ▶ Digitalization of shop-floor data via Desklink
- ▶ Structured and documented team meetings
- ▶ Customer-oriented configuration thanks to intuitive web application
- ▶ Time-saving automatic minutes function
- ▶ Space-saving

## Features

- ▶ Web-based ActiveCockpit software on annual lease
- ▶ Licenses can be purchased for additional users

## Basic package

- ▶ Modules: Dashboard, Views, Meetings, Notes, Whiteboard, Desklink
- ▶ 10x concurrent user license
- ▶ 1x device license
- ▶ 1x administrator rights

ActiveCockpit basic package	No.
1-year lease	<b>3 842 558 253</b>
Lease for another 12 months	<b>3 842 558 276</b>

ActiveCockpit licenses	No.
10 concurrent users	<b>3 842 551 110</b>
1 device	<b>3 842 557 111</b>

## Function description

### Desklink

- ▶ Fast digitization of data from different file formats, e.g., Excel, Word, PowerPoint
- ▶ Data is updated automatically
- ▶ Interactive widget status change

### Dashboard

- ▶ All relevant data digitally available on site
- ▶ Information from different file formats can be displayed, e.g., Excel, PowerPoint, video
- ▶ Accessible to all employees

### Views

- ▶ Fast compilation of data and documents, e.g., for improvement meetings
- ▶ Individual assignment of user authorizations, including read, edit, delete
- ▶ Information can be displayed and used across departments, documents are updated via Desklink
- ▶ Filter and display relevant information without editing the original file

### Meetings

- ▶ Operator can assign individual names for each plant
- ▶ Documentation of meetings with freely selectable components and individually definable structure
- ▶ Automatic minuting with all relevant information and attachments to the discussed topics

### Notes and whiteboard functionality

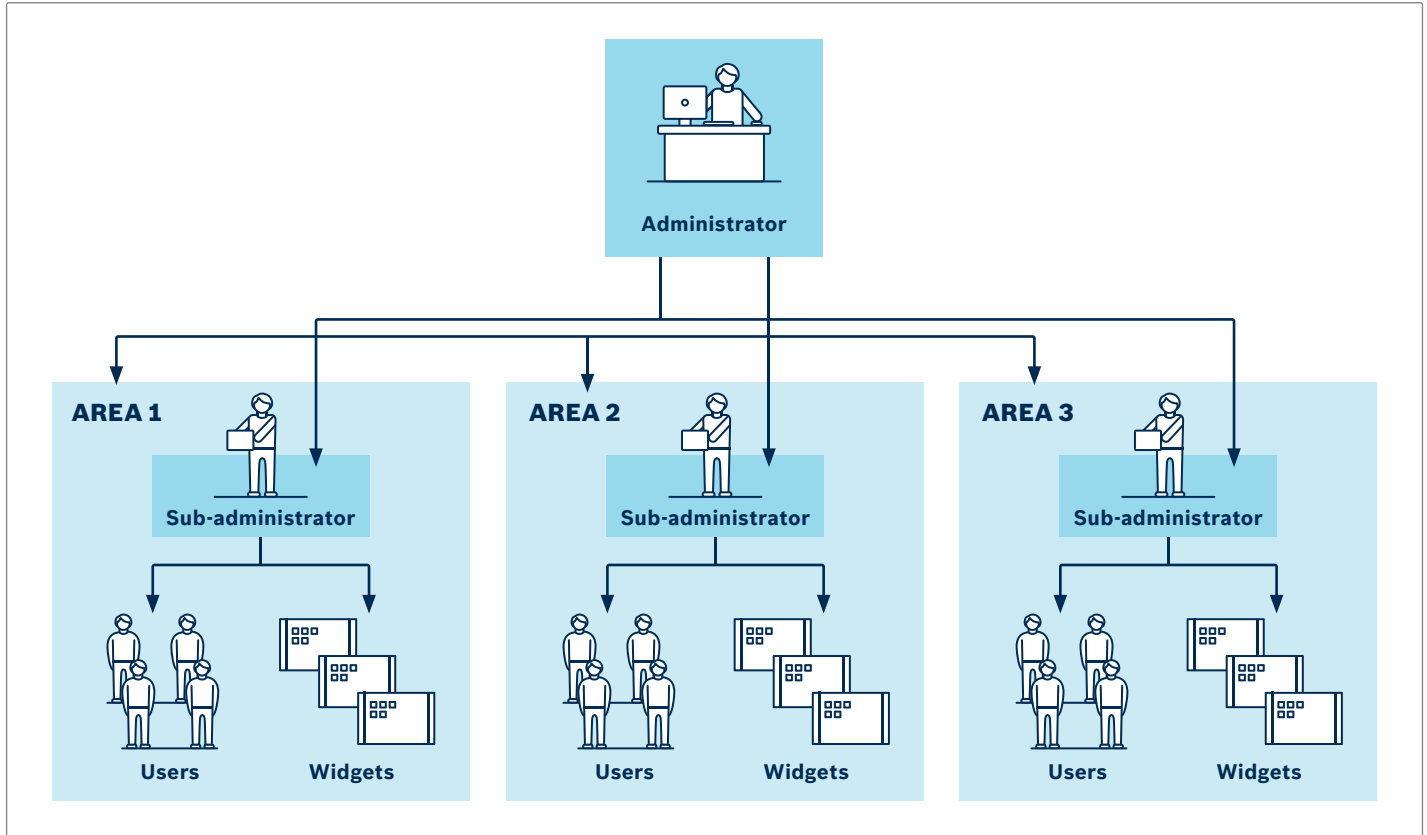
- ▶ Note function for communicating with colleagues or for escalating during the meeting
- ▶ Annotation function via touchscreen for marking, commenting directly in ActiveCockpit
- ▶ Display and transmit relevant information. In case of malfunctions, a photo can be taken via tablet and forwarded to ActiveCockpit for evaluation

### Inter app communication

- ▶ App contents can be shared and used with other apps
- ▶ This prevents double data acquisition and secures fast communication
- ▶ Example: A manually recorded deviation in the LeanIndicator can be shared with the DeviationManager in order to develop a sustainable solution, and a generated trigger from the App Diagram is sent to the DeviationManager

### Data security:

- ▶ All data including e-mail dispatch are transmitted encrypted
- ▶ All user inputs are checked for correctness and malicious code
- ▶ Application uses defensive programming methods that review all entries in advance
- ▶ A defined role and authorization concept controls access to the system and prevents errors during data entry
- ▶ All passwords are stored encrypted in the database to prevent disclosure in case database is compromised.
- ▶ Indirect database queries eliminate potential attacks (SQL injections)



### Area Manager

- ▶ Hierarchical user and content management
- ▶ Reduced need for central administrators
- ▶ Decentralized user and content management "on site"
- ▶ Organizational separation promotes clarity and better delineates responsibilities
- ▶ Releasing widgets between areas facilitates inter-hierarchical work with content
- ▶ Separate dashboards per area can be configured individually

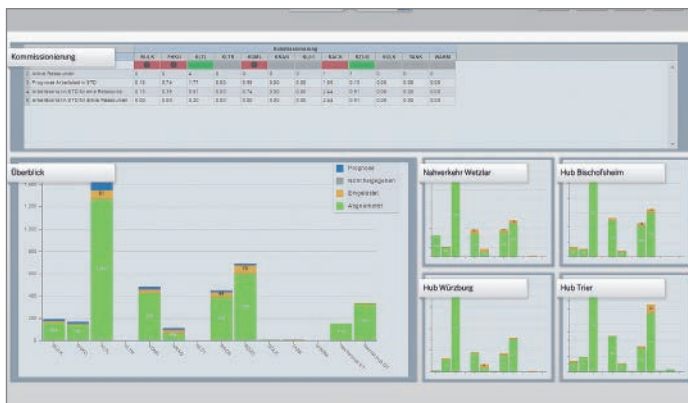
Area Manager	No.
1-year lease	<b>3 842 558 266</b>
Lease for another 12 months	<b>3 842 558 267</b>



## ActiveCockpit – application software

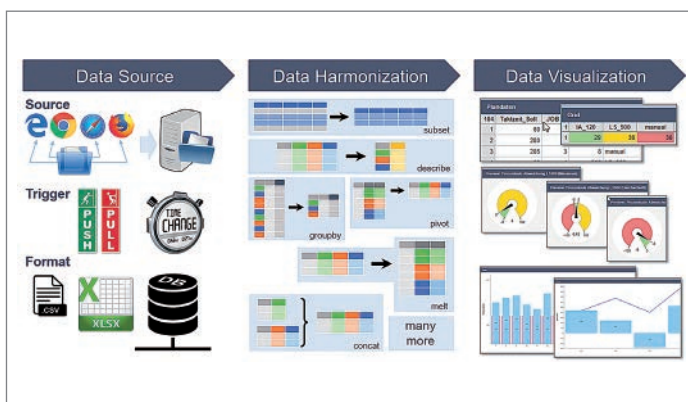
### Extensions for customers

Bosch Rexroth offers its clients project-specific services that go far beyond just engineering services. Supported services include start-up, training and App Diagram

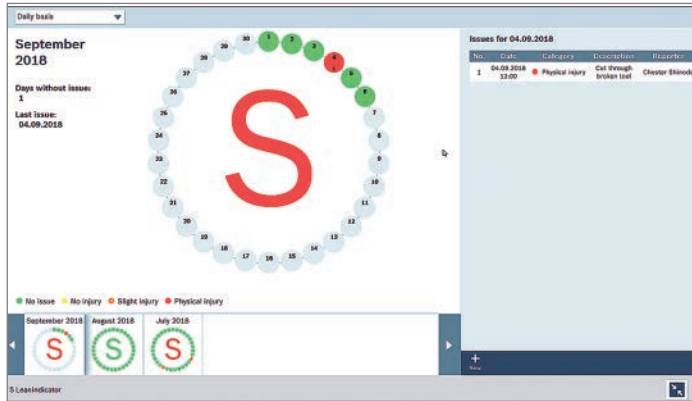


### App Diagram

- ▶ App for networking your production data and visualizing your key figures in real time
- ▶ In just three steps you can digitize your production figures and integrate them into your dashboard in real time.
  - Connect data
  - Process data
  - Display data



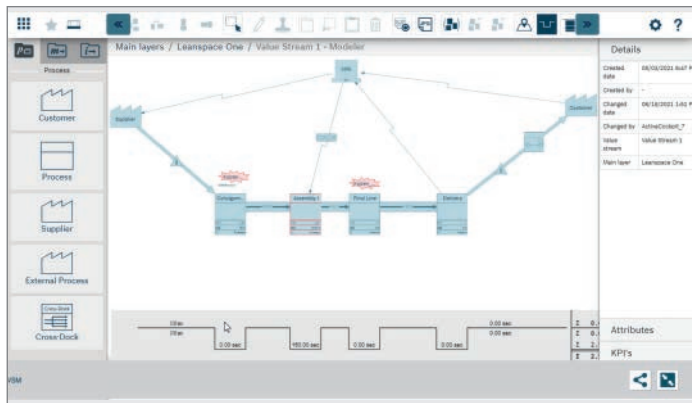
App Diagram	No.
Lease for 1 year per area	3 842 558 256
Lease for another 12 months per area	3 842 558 257
10 users (lease for 1 year)	3 842 562 624
1 device (lease for 1 year)	3 842 562 625



## LeanIndicator

- ▶ App to support the visualization of your key figures and to increase transparency
- ▶ Employees can enter and manage quality and safety deviations on site at the click of a mouse
- ▶ The admin view can be used to configure incident types to increase employee acceptance
- ▶ Ideal for implementing lean standard
- ▶ Key figure simply networked to minimize waste (time, errors, paths)

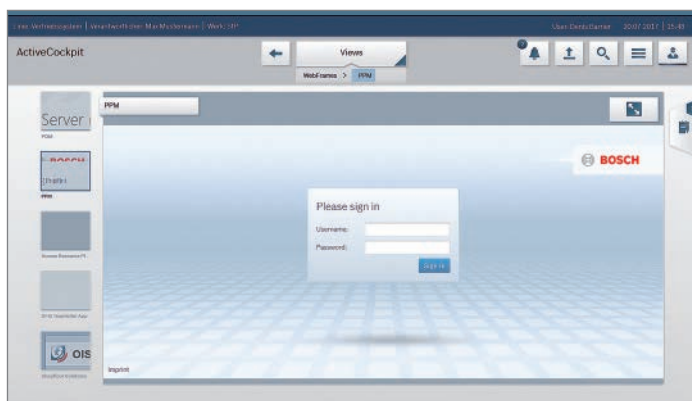
LeanIndicator	No.
Lease for 1 year (per area)	<b>3 842 559 889</b>
Lease for another 12 months (per area)	<b>3 842 559 889</b>



## ValueStreamManager

- ▶ Application of the lean management
- ▶ Implementation of the value stream method:
  - Recording of the actual condition
  - Creation of a vision
  - Derivation of a target condition
- ▶ Value stream mapping and design are digitally prepared
- ▶ Value-adding / non-value-adding activities are calculated and visualized in a transparent manner.
- ▶ Current and consistent key figures allow decisions to be made quickly and sustainably on the shop floor.

ValueStreamManager	No.
Lease for 1 year (per area)	<b>3 842 562 823</b>
Lease for another 12 months (per area)	<b>3 842 562 824</b>
10 users 3M (lease for a 3-month trial)	<b>3 842 562 825</b>
1 device (lease for 1 year)	<b>3 842 563 547</b>
10 users (lease for 1 year)	<b>3 842 563 548</b>



## WebFrame

- ▶ Customer-specific web applications integrated as widgets
- ▶ Third-party web applications embedded via URL

WebFrame	No.
Lease for 1 year per area	3 842 558 254
Lease for another 12 months per area	3 842 558 255



## WebFrame CheckIn

- ▶ Image display with caption
- ▶ Display refreshed regularly
- ▶ Clicking on the report opens the web application
- ▶ User rights automatically given to third-party web applications
- ▶ User-friendly admin UI for configuring links and authorizations

## Requirements

- ▶ Target application must provide a web service for authentication
- ▶ Target application must run in the same domain or sub-domain as ActiveCockpit
- ▶ Target application must provide static links to images as well as the proper Deeplink

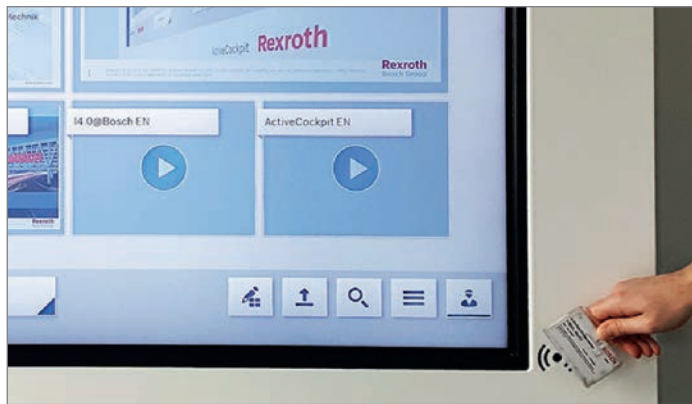
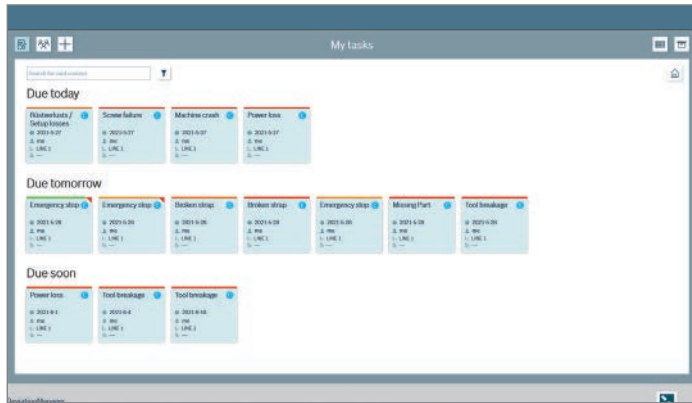
WebFrame CheckIn	No.
Lease for 1 year per area	3 842 558 262
Lease for another 12 months per area	3 842 558 263



## DeviationManager

- ▶ Data import from MES via a web service for easy processing
- ▶ Deviation classification and tracking
- ▶ Classified deviations displayed clearly (status, priority, revisit) for employees
- ▶ Close remedied incidents or set to revisit
- ▶ Freely selectable user interface: "Moderator" or "My incidents"

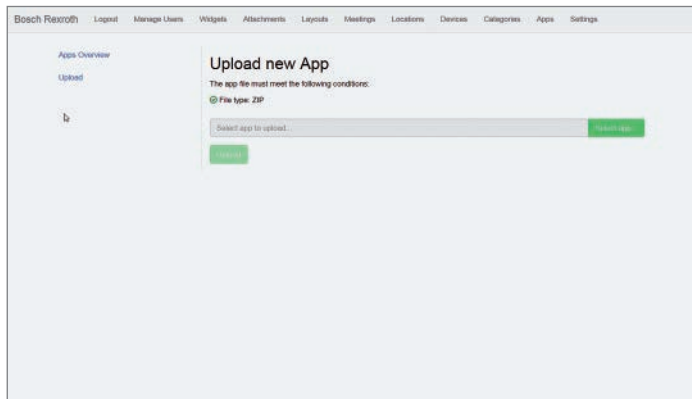
DeviationManager	No.
1-year lease	3 842 558 260
Lease for another 12 months	3 842 558 261



## Card Identification

- ▶ App for easy system login via employee ID
- Required accessories: CardReader (page 11-12)  
 Recommended accessories: Registration cards

Card Identification	No.
Lease for 1 year per card reader	3 842 558 273
Lease for another 12 months per card reader	3 842 558 274



## AppConnector

- ▶ For integrating in-house applications into ActiveCockpit
- ▶ Individual functionality expansion for adding customer apps to the ActiveCockpit platform

AppConnector	No.
1-year lease	3 842 558 264
Lease for another 12 months	3 842 558 265

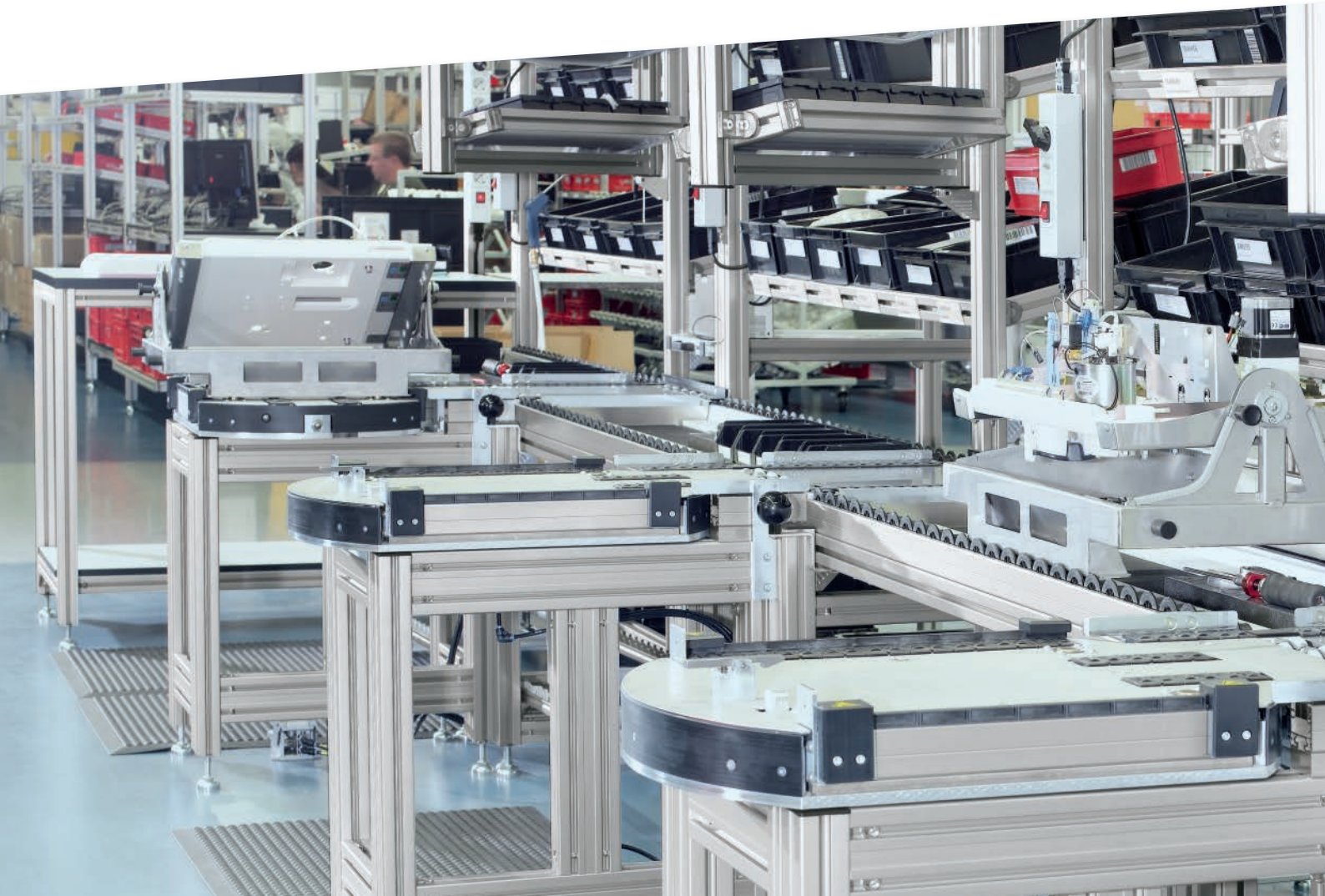


## CardReader

RFID card reader for logging into board with registration card

- ▶ Increases security when logging onto a 65" touchscreen
- ▶ 3-LED status indicator
- ▶ USB 2.0 connection
- ▶ Cable length: 2 m
- ▶ Dimensions: 112 x 54 x 27 mm
- ▶ Can be mounted on a white frame
- ▶ IP 40
- ▶ Compatible with existing plant IDs (have validated by your Rexroth consultant)

Card reader	No.
	<b>3 842 558 271</b>



# Continuous improvement and self-assembly of your systems

**In addition to the systems and modules on offer, you can also choose to build your own system from individual components.**

This chapter has been compiled to provide you with a summary of the components you will need for the different parts of your system. The expansion and continuous improvement of existing systems is the key to long-term success. Employees experience and learn new things every day. And this knowledge should be quickly integrated into your assembly systems. Our MPS program is the modular system you need to achieve continuous improvement.



## OVERVIEW OF COMPONENTS

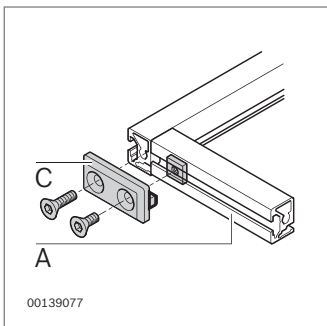
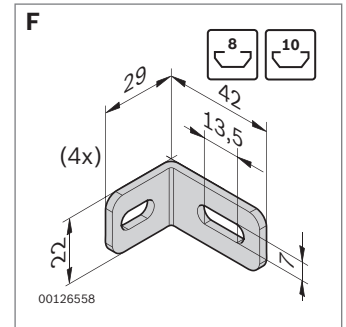
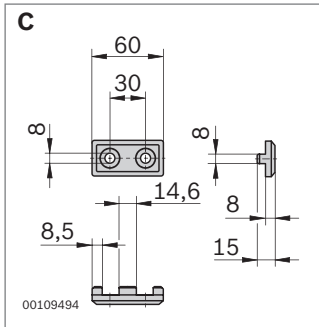
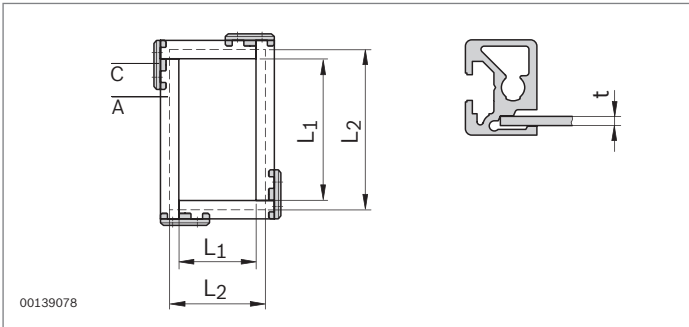
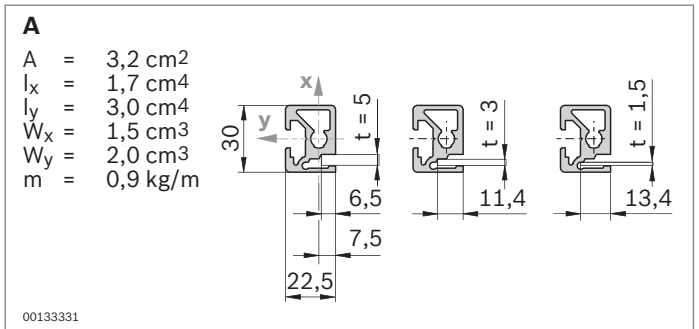
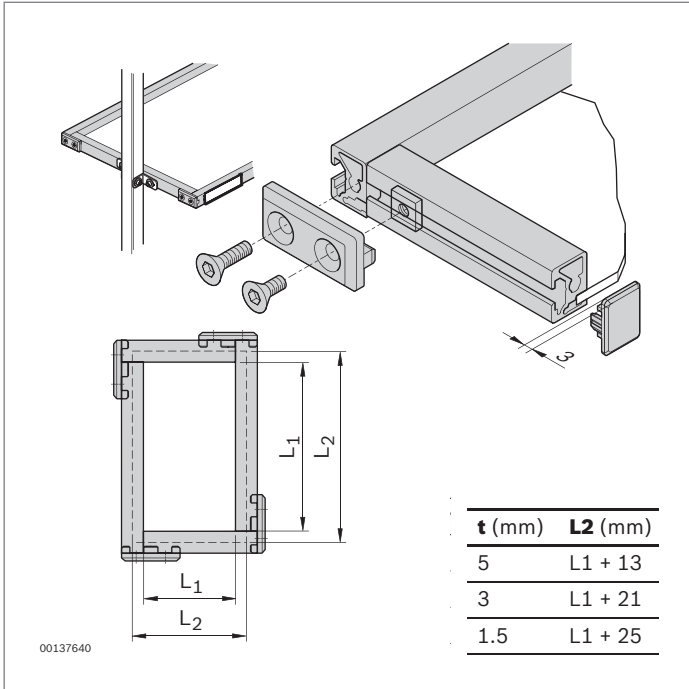
- 12-3** Material shelves
- 12-5** Conveyor level
- 12-6** Accessory upright
- 12-7** Reinforcements, lateral guides
- 12-8** Hanger
- 12-9** Grab containers, tool shelves, suspension profiles
- 12-10** Supporting arms
- 12-12** Material shuttles
- 12-13** Supporting brackets, foundation brackets, table top supports

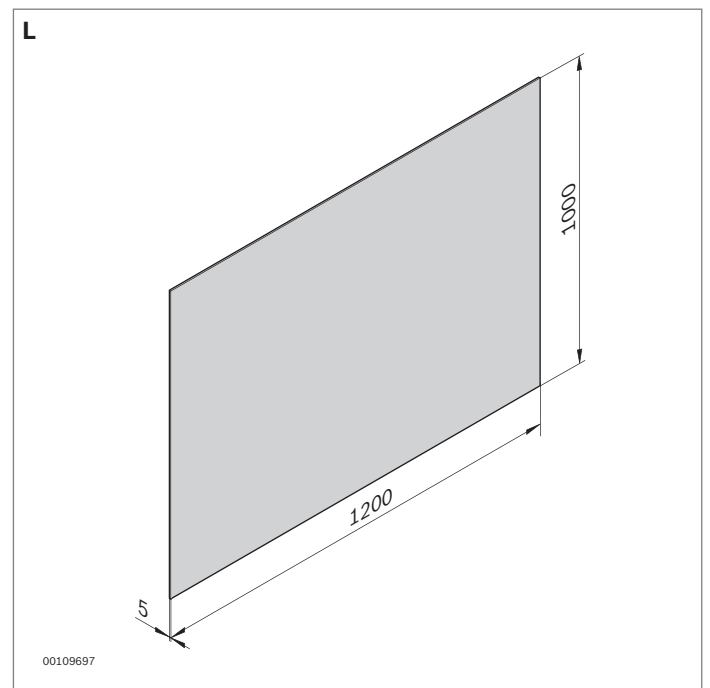
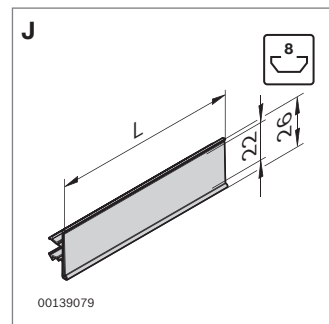
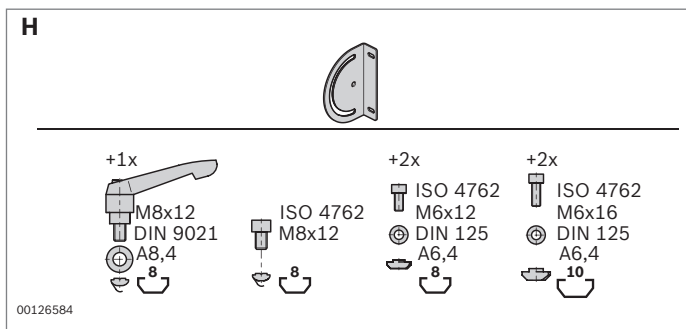
Again and again, new product variants or new customer demands compel you to rethink and revise your existing system. Make this job easier for yourself by using the Manual Production System and its components.

You will also find a short extract from other Rexroth offerings here including Basic Mechanic Elements. For simple and efficient planning and layout we recommend using *MTpro*.



### Material shelf Economic self-assembly elements





	L (mm)			ESD No.
<b>A</b> 22.5 x 30 frame profile, material: Aluminum, anodized	50 ... 6070	1		<b>3 842 992 493/L</b>
	6070	20		<b>3 842 557 946</b>
<b>C</b> 22.5 x 30 corner piece, material: PA, black			20	<b>3 842 554 709</b>
	22.5 x 30 corner piece, material: PA, signal gray		20	<b>3 842 554 708</b>
<b>F</b> M6 bracket set, incl. fastening material for 8/10 mm slot; material: Steel, galvanized			Set	<b>3 842 537 862</b>
<b>H</b> Swivel mounting, incl. fastening material for 8 mm slot; material: Steel, galvanized			Set	<b>3 842 538 275</b>
<b>J</b> Labeling clip for 8 mm slot; material: PVC	2000		20	<b>3 842 537 113</b>
	102		20	<b>3 842 537 650</b>
<b>L</b> Plate for frame profile; material: PP, gray, smooth on one side, textured on the other				<b>3 842 516 837</b>
	Plate for frame profile; material: SB, black, smooth on both sides			<b>3 842 516 838</b>

### Material shelf Basic self-assembly elements

t (mm)	L2 (mm)	A (mm)
5	L1 + 13	0
3	L1 + 21	15
1.5	L1 + 29	23

00137638

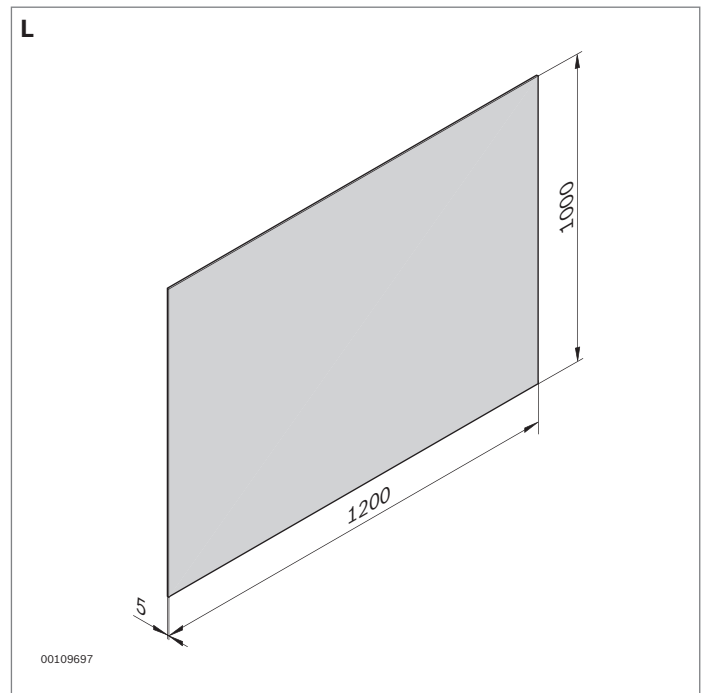
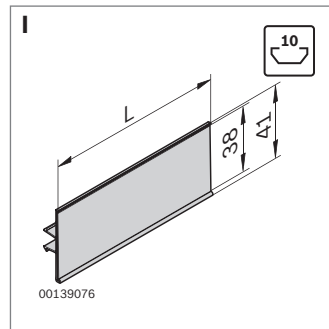
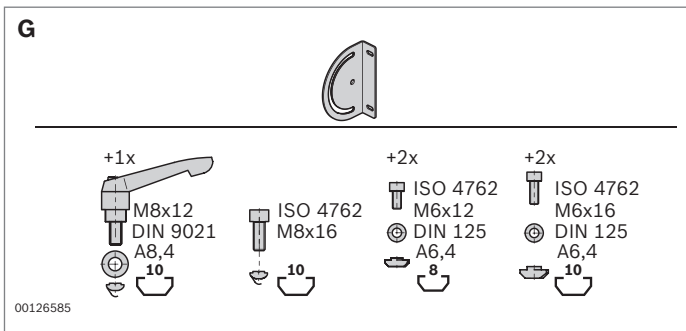
00139074

00109286

00139075

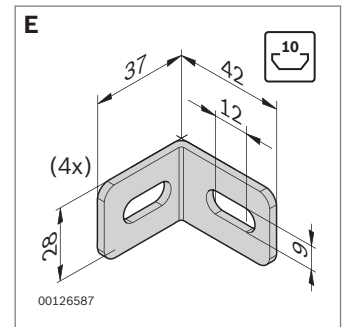
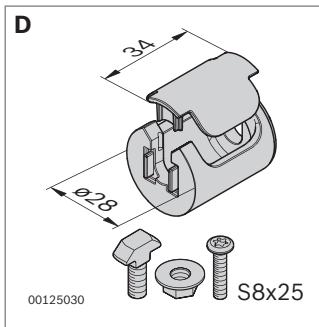
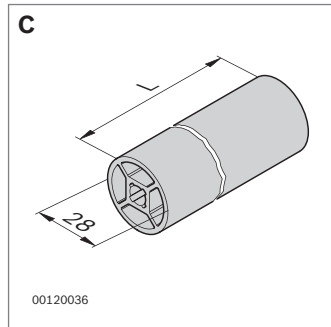
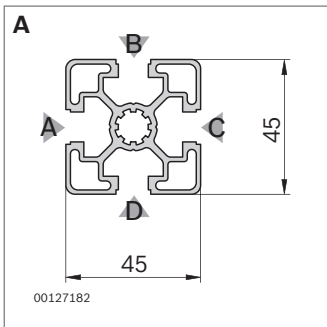
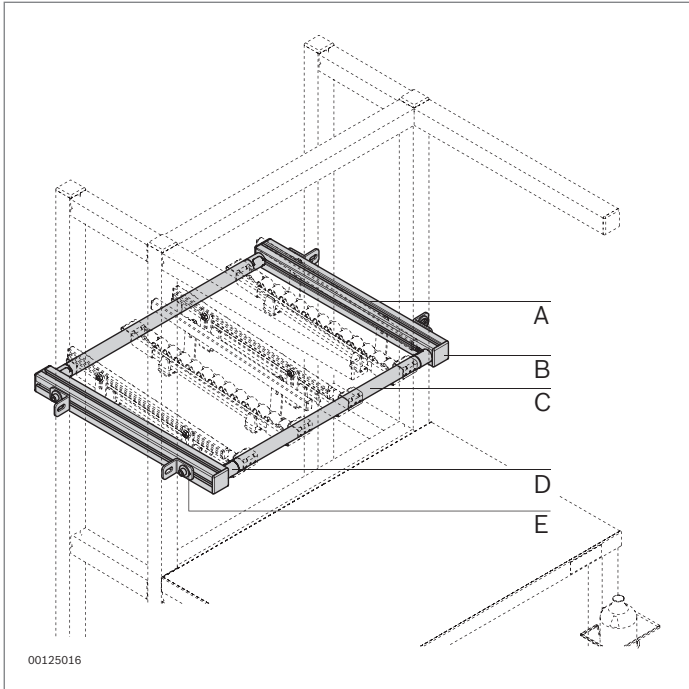
00109492

00126587



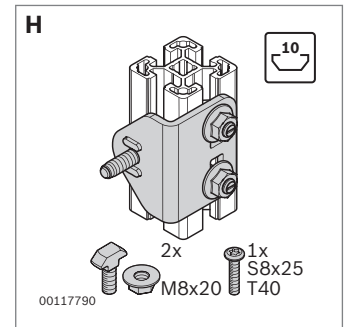
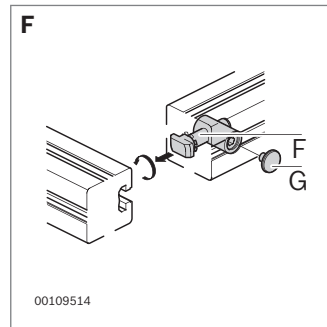
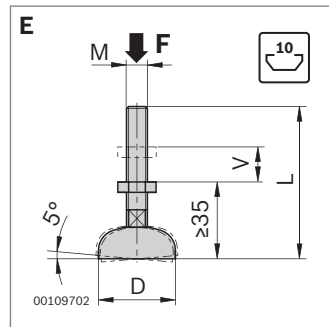
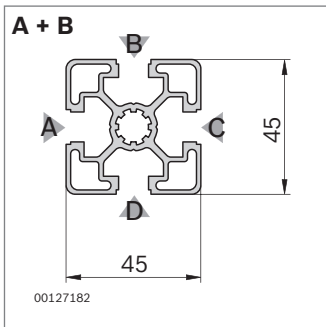
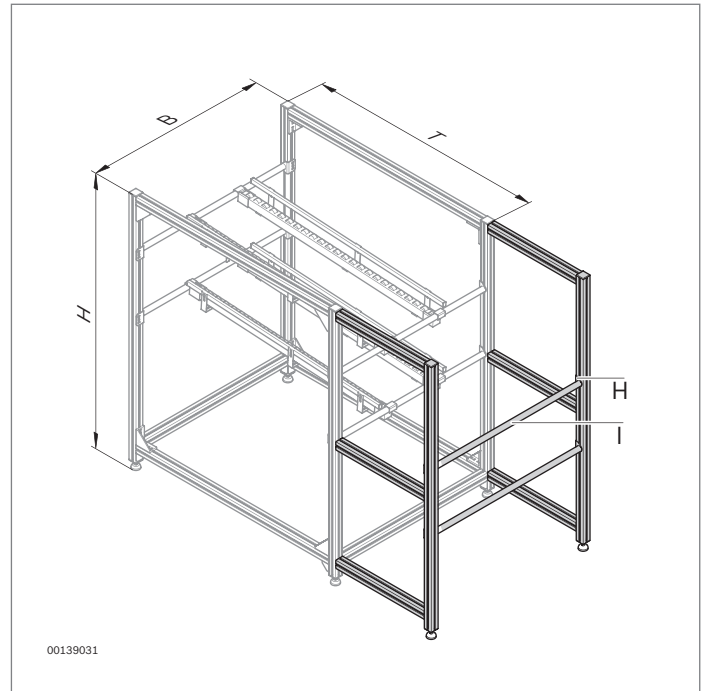
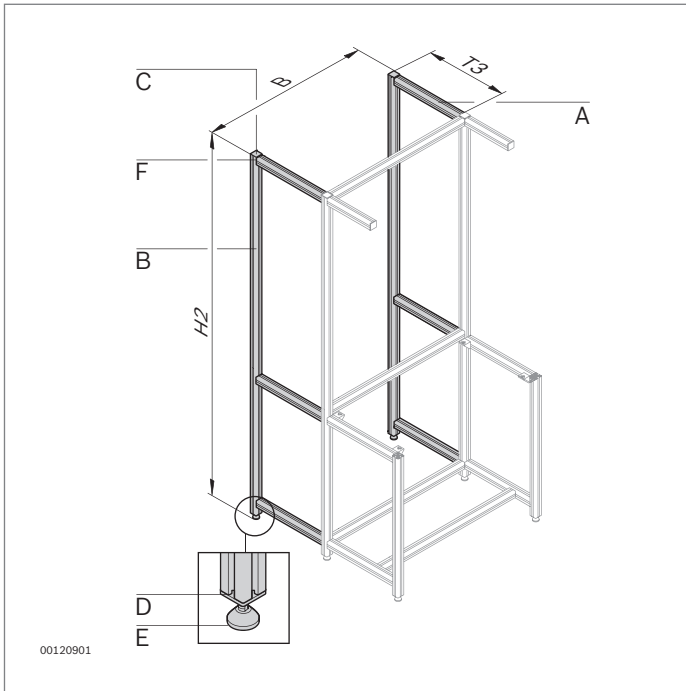
	L (mm)			ESD	No.
<b>B</b> 22.5x45C frame profile; material: Aluminum; anodized	50 ... 6070	1			<b>3 842 992 411/L</b>
	6070	20			<b>3 842 557 941</b>
<b>D</b> 22.5x45 corner piece; material: Diecast zinc			20		<b>3 842 535 637</b>
<b>E</b> M8 bracket set, incl. fastening material for 10 mm slot; Material: Steel; zinc-plated			Set		<b>3 842 537 861</b>
<b>G</b> Swivel mounting, incl. fastening material for 10 mm slot; Material: Steel; zinc-plated			Set		<b>3 842 538 276</b>
<b>I</b> Labeling clip for 10 mm slot; Material: PVC	2000		20		<b>3 842 537 116</b>
	102		20		<b>3 842 537 651</b>
<b>L</b> Plate for frame profile; material: PP, gray, smooth on one side, textured on the other					<b>3 842 516 837</b>
	Plate for frame profile; material: SB, black, smooth on both sides				<b>3 842 516 838</b>

## Conveyor level self-assembly elements



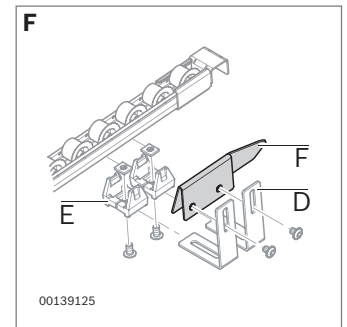
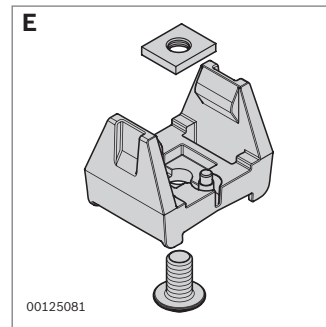
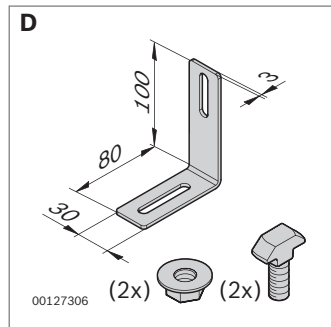
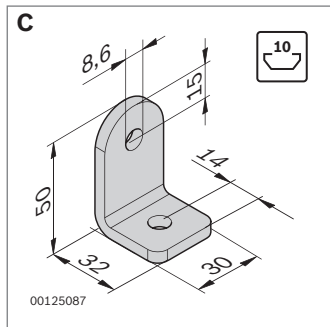
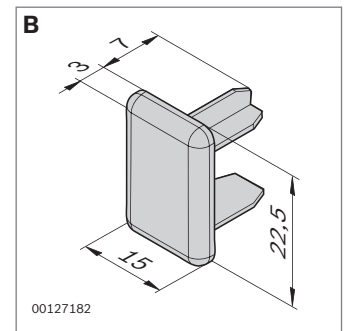
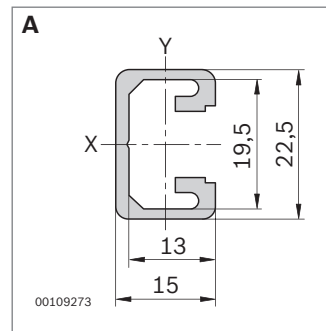
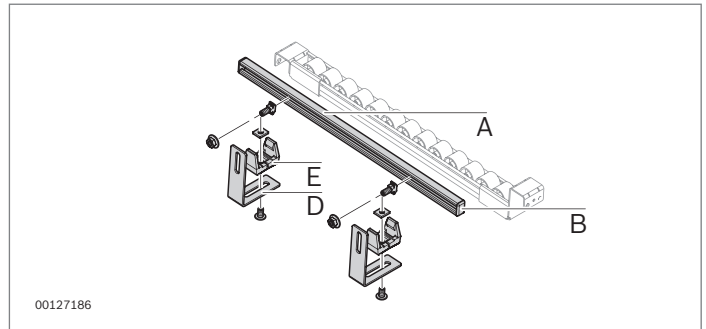
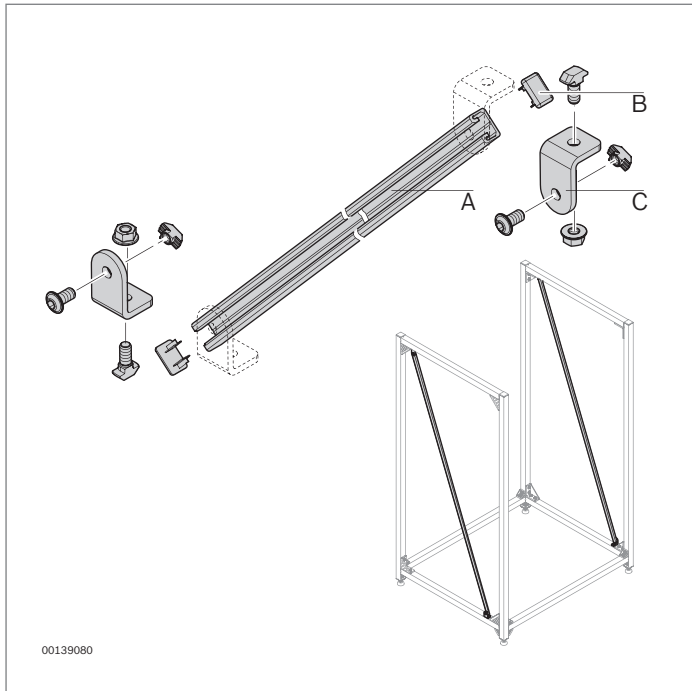
	L (mm)		ESD	No.
<b>A</b> 45x45L strut profile; material: Aluminum; anodized	50 ... 6070	1		<b>3 842 993 737/L</b>
	6070	20		<b>3 842 553 611</b>
<b>B</b> 45x45L cover cap; material: PP, black 45x45L cover cap; material: PP, signal gray			20	<b>3 842 548 753</b>
			100	<b>3 842 548 752</b>
<b>C</b> D28 round tube; material: Aluminum; anodized	50 ... 6070	1		<b>3 842 993 317/L</b>
	6070	20		<b>3 842 535 118</b>
	6070	1		<b>3 842 564 212</b>
<b>D</b> D28 T-connector			20	<b>3 842 532 879</b>
<b>E</b> M8 bracket set, incl. fastening material for 10 mm slot; material: Steel; zinc-plated			Set	<b>3 842 537 861</b>

## Accessory upright



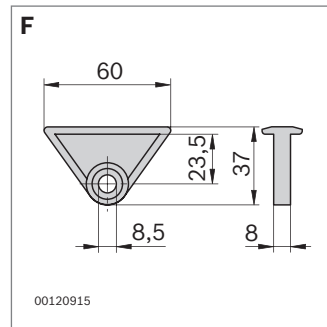
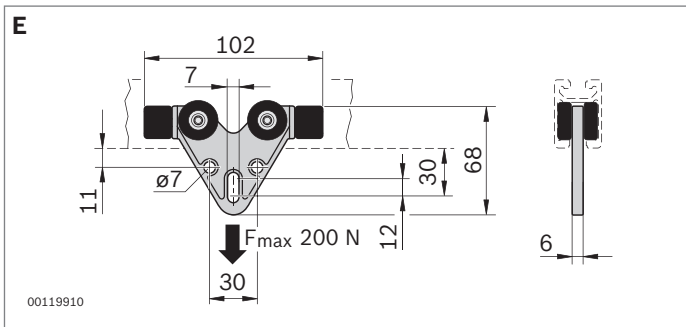
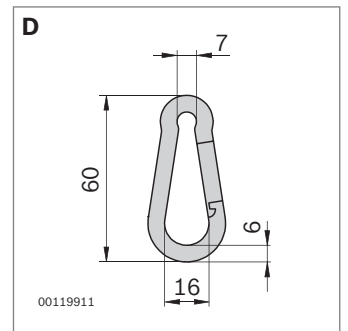
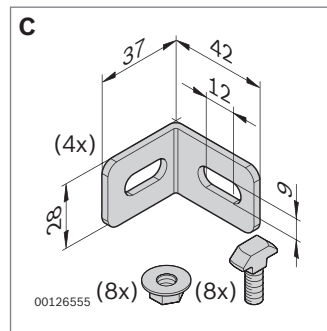
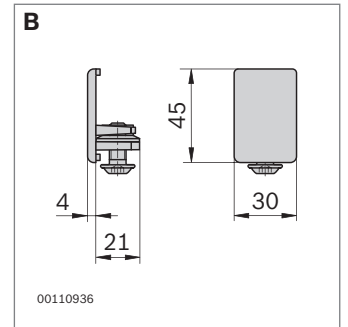
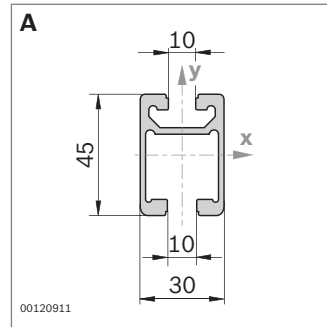
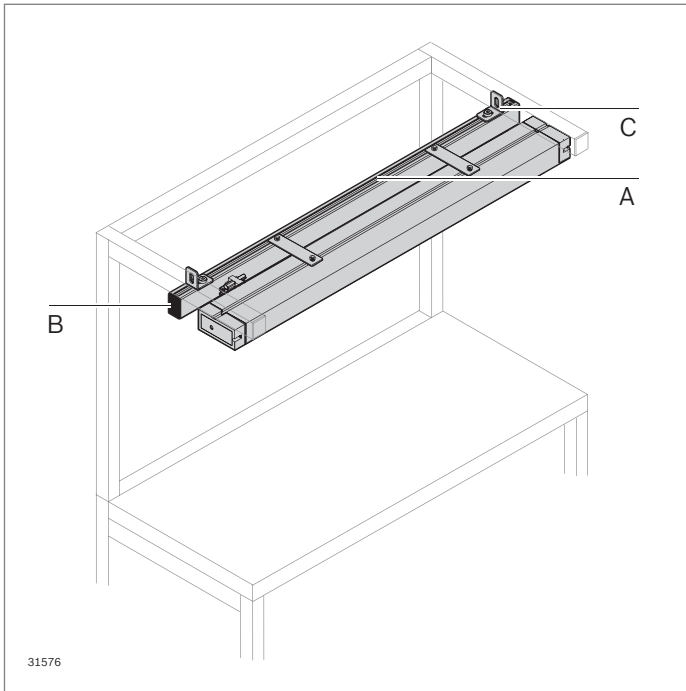
		L (mm)		ESD	No.
<b>A</b>	45x45L strut profile, DB17 profile machining (through hole Ø17) on both profile ends; material: Aluminum; anodized	50 ... 6070	1		<b>3 842 993 737/L/ B=DB17/DB17</b>
<b>B</b>	45x45L strut profile, M12 profile machining (thread in core) on one profile end; material: Aluminum; anodized	50 ... 6070	1		<b>3 842 993 737/L/ Z=M12/-</b>
<b>A, B</b>	45x45L strut profile; material: Aluminum; anodized	6070	20		<b>3 842 553 611</b>
<b>C</b>	45x45L cover cap; material: PP, black			20	<b>3 842 548 753</b>
	45x45L cover cap; material: PP, signal gray			100	<b>3 842 548 752</b>
<b>D</b>	45x45L cover cap with hole; material: PP, black			20	<b>3 842 548 797</b>
	45x45L cover cap with hole; material: PP, signal gray			20	<b>3 842 548 796</b>
<b>E</b>	D44 leveling foot; material: Steel; zinc-plated			20	<b>3 842 352 061</b>
<b>F</b>	D17 quick connector for 10 mm slot (0°)			10	<b>3 842 535 458</b>
<b>G</b>	Quick connector cover cap; material: PA			100	<b>3 842 538 564</b>
<b>H</b>	Holding bracket with connection kit; material: Steel; zinc-plated			20	<b>3 842 536 002</b>
<b>I</b>	D28 round tube; material: Aluminum; anodized (see Figure "C" on page 12-8)	50 ... 6070	1		<b>3 842 993 317/L</b>
		6070	20		<b>3 842 535 118</b>

## Reinforcement self-assembly element Lateral guide self-assembly element



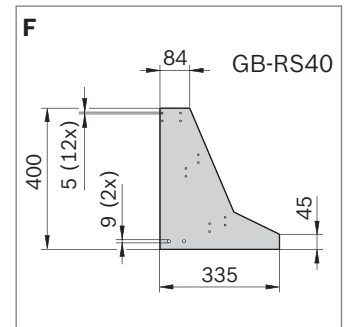
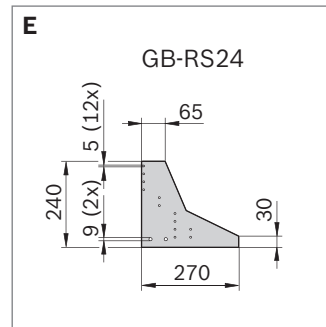
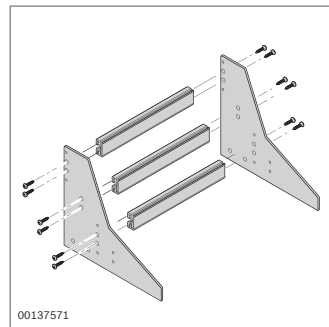
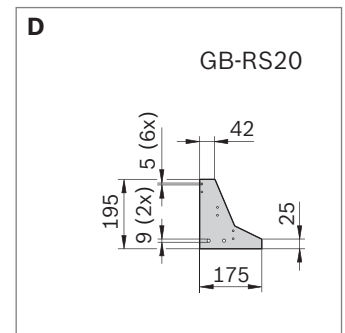
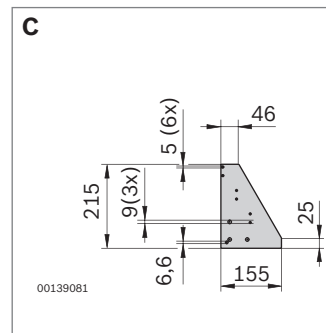
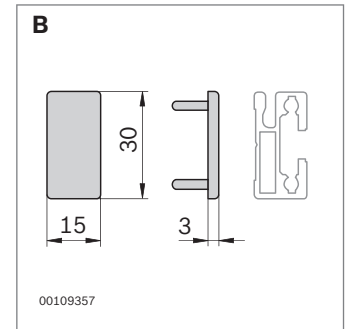
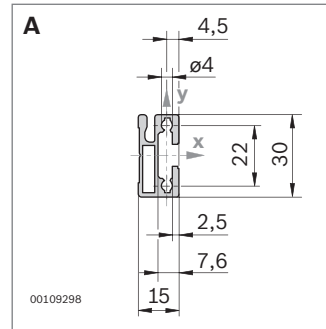
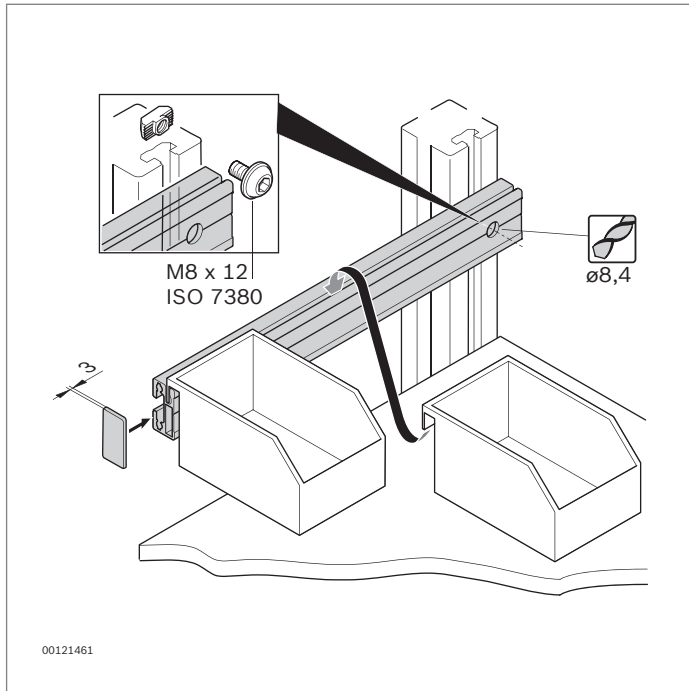
	L (mm)		ESD	No.
<b>A</b> 15x22.5 profile; material: Aluminum; anodized	50 ... 3000	1		<b>3 842 992 473/L</b>
	3000	10		<b>3 842 563 231</b>
	3000	1		<b>3 842 563 232</b>
<b>B</b> 15x22.5 cover cap; material: PP, black 15x22.5 cover cap; material: PP, signal gray		20	⚠	<b>3 842 548 817</b>
		20		<b>3 842 548 816</b>
<b>C</b> Bracket set, incl. fastening material for 10 mm slot; Material: Steel; zinc-plated		20		<b>3 842 536 729</b>
<b>D</b> Bracket set, incl. fastening material for 10 mm slot; Material: Steel; zinc-plated		20		<b>3 842 535 125</b>
<b>E</b> Adapter for XLean conveyor track; material: PA		20	⚠	<b>3 842 537 022</b>
<b>F</b> Right and left guide plate, incl. fastening material		Set		<b>3 842 538 981</b>

## Hanger self-assembly elements



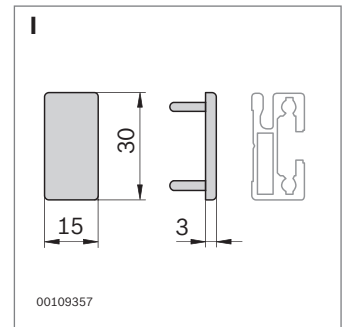
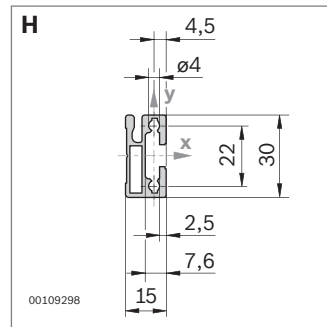
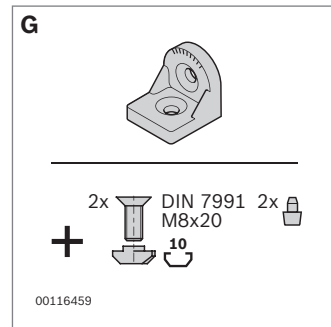
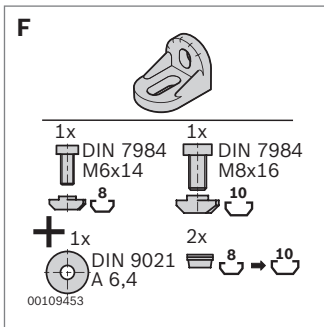
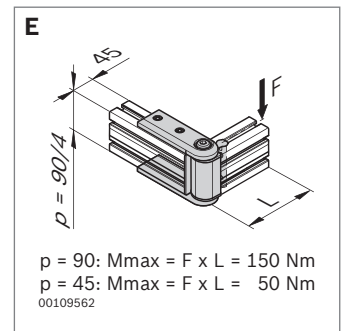
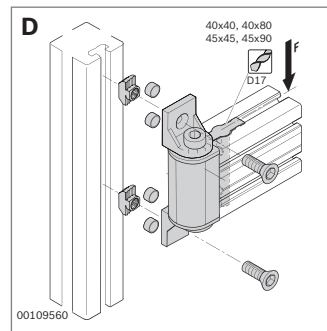
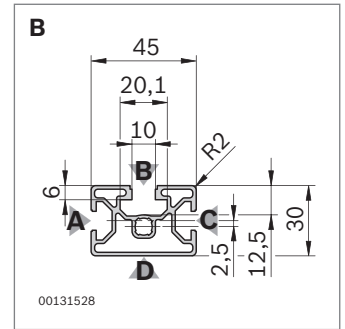
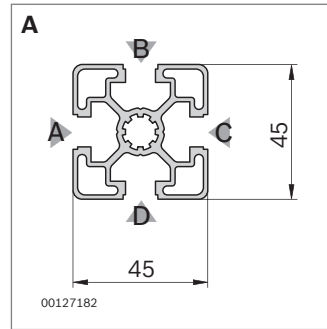
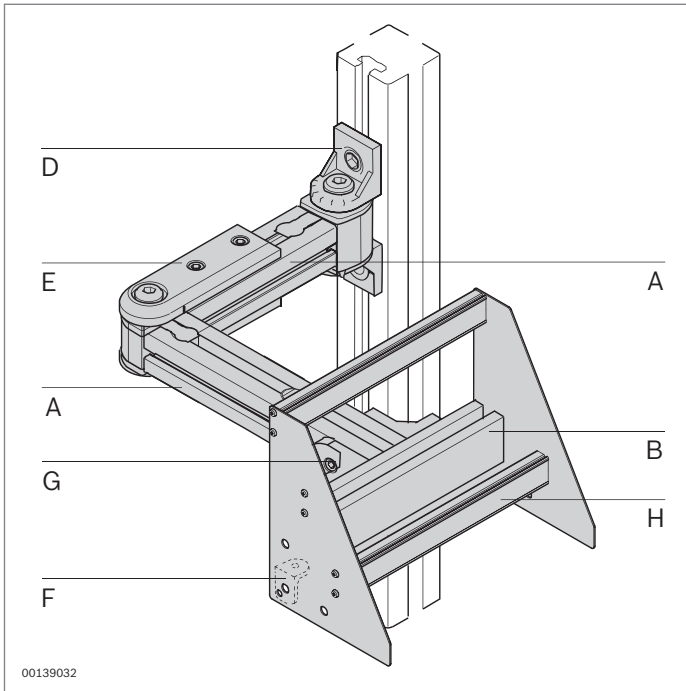
	L (mm)		ESD	No.
<b>A</b> 30x45C profile rail; Material: Aluminum; anodized	50 ... 6070	1		<b>3 842 992 946/L</b>
	6070	20		<b>3 842 557 950</b>
<b>B</b> 30x45C end piece; material: PA, black 30x45C end piece; material: PA; signal gray			20	<b>3 842 554 711</b>
			20	<b>3 842 554 710</b>
<b>C</b> M8 bracket set, incl. fastening material for 10 mm slot; material: Steel; zinc-plated			Set	<b>3 842 537 861</b>
<b>D</b> Snap hook; material: Steel; zinc-plated				<b>0 842 901 309</b>
<b>E</b> Trolley for 30x45C profile rail				<b>3 842 521 510</b>
<b>F</b> Slide hanger for profiles with 10 mm slot; Material: POM				<b>3 842 218 953</b>

**Grab container self-assembly element, Tool shelf self-assembly element, Suspension profiles**



	L (mm)			ESD	No.
<b>A</b> Suspension profile; material: Aluminum; anodized	30 ... 3000	1			<b>3 842 993 411/L</b>
	3000	10			<b>3 842 537 679</b>
Suspension profile; material: Aluminum, natural	30 ... 3000	1			<b>3 842 993 063/L</b>
	3000	10			<b>3 842 554 157</b>
<b>B</b> 15x30 suspension profile cover cap; material: PP, black			20		<b>3 842 551 583</b>
15x30 suspension profile cover cap; material: PP, signal gray			20		<b>3 842 551 582</b>
<b>C</b> Side plate for tool shelf (2 pcs); material: Sheet aluminum			Set		<b>3 842 553 996</b>
<b>D</b> Side plate for GB-RS20 grab container rack (2 pcs); material: Sheet aluminum			Set		<b>3 842 517 399</b>
<b>E</b> Side plate for GB-RS24 grab container rack (2 pcs); material: Sheet aluminum			Set		<b>3 842 517 400</b>
<b>F</b> Side plate for GB-RS40 grab container rack (2 pcs); material: Sheet aluminum			Set		<b>3 842 517 401</b>
<b>G</b> M8 T-nut for 10 mm slot			100		<b>3 842 530 287</b>

## Supporting arms self-assembly elements

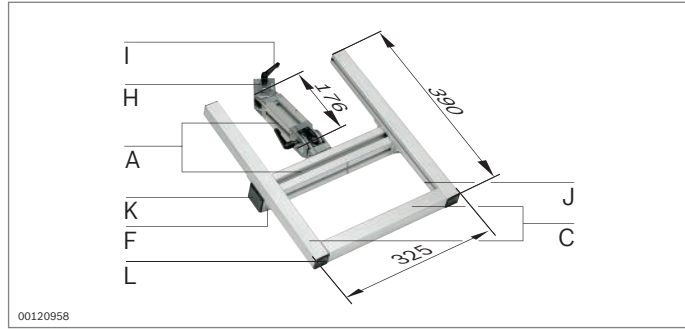


		L (mm)		ESD	No.
<b>A</b>	45x45L strut profile, DB17 profile machining (through hole Ø17) on one profile end; material: Aluminum; anodized	50 ... 6070	1		<b>3 842 993 737/L/ A=D17/-</b>
		6070	20		<b>3 842 553 611</b>
<b>B</b>	30x45 strut profile; material: Aluminum; anodized	50 ... 6070	1		<b>3 842 993 710/L</b>
		6070	18		<b>3 842 557 203</b>
<b>D</b>	45x90 swivel bearing, incl. fastening material for 10 mm slot; material: Diecast zinc				<b>3 842 554 410</b>
<b>E</b>	45x90 supporting arm joint, incl. fastening material for 10 mm slot; material: Diecast zinc				<b>3 842 554 426</b>
<b>F</b>	R28x38 bracket, incl. fastening material for 8 mm slot; material: Diecast zinc				<b>3 842 515 547</b>
<b>G</b>	R35x38 bracket, incl. fastening material for 10 mm slot; material: Diecast aluminum				<b>3 842 532 274</b>
<b>H</b>	Suspension profile; material: Aluminum; anodized	30 ... 3000	1		<b>3 842 993 411/L</b>
		3000	10		<b>3 842 537 679</b>
		30 ... 3000	1		<b>3 842 993 063/L</b>
	Suspension profile; material: Aluminum, natural	3000	10		<b>3 842 554 157</b>
<b>I</b>	15x30 suspension profile cover cap; material: PP, black		20		<b>3 842 551 583</b>
	15x30 suspension profile cover cap; material: PP, signal gray		20		<b>3 842 551 582</b>

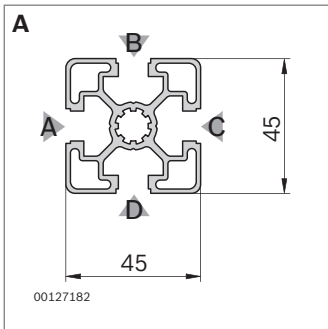
## Supporting arms self-assembly elements



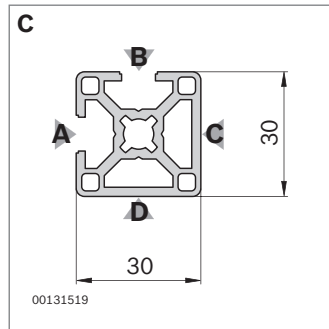
00120957



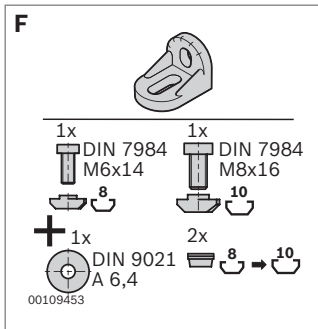
00120958



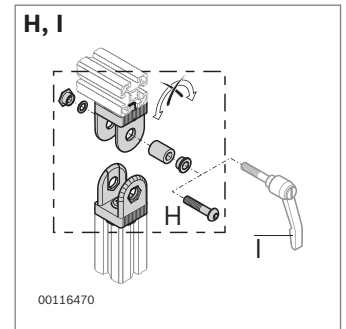
00127182



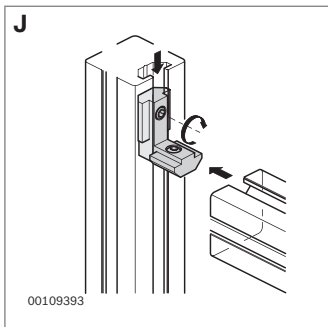
00131519



00109453



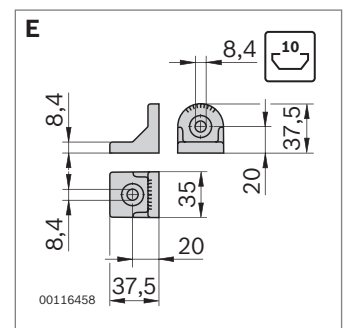
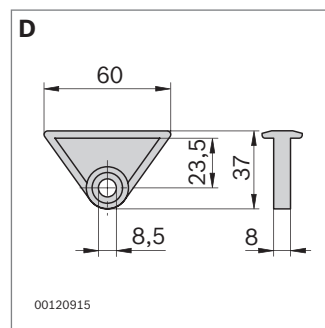
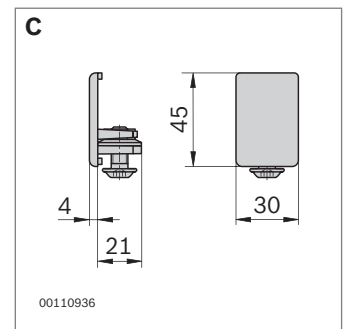
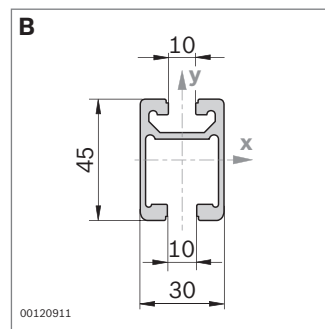
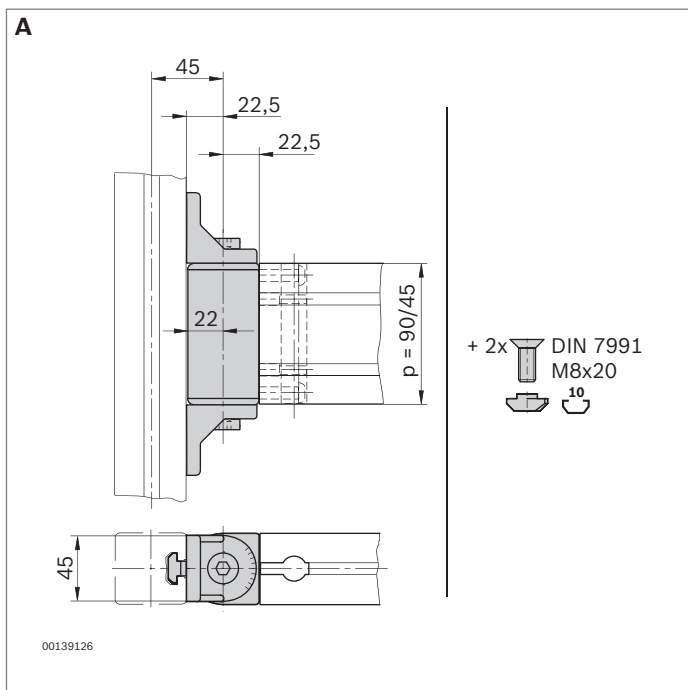
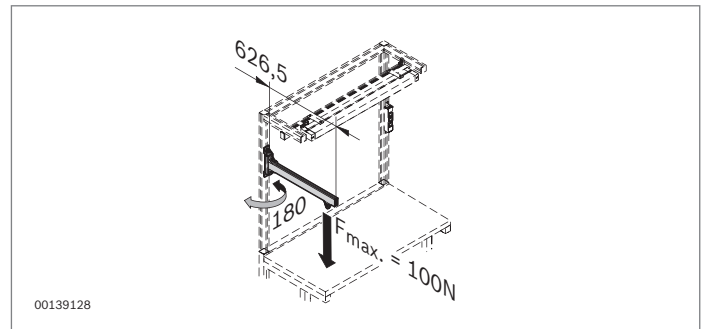
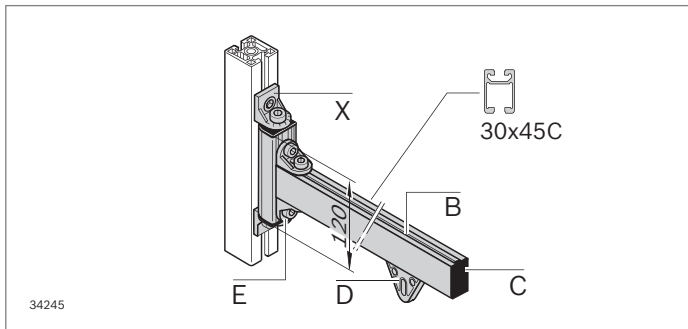
00116470



00109393

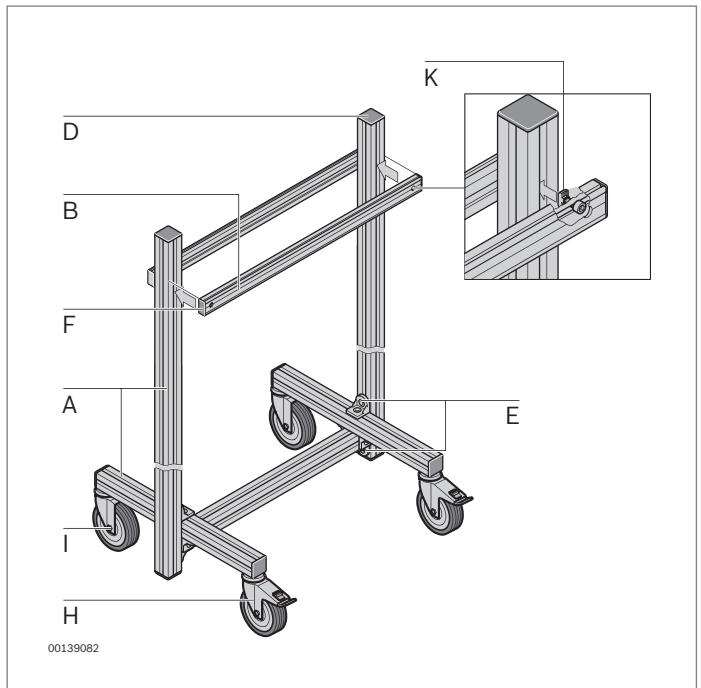
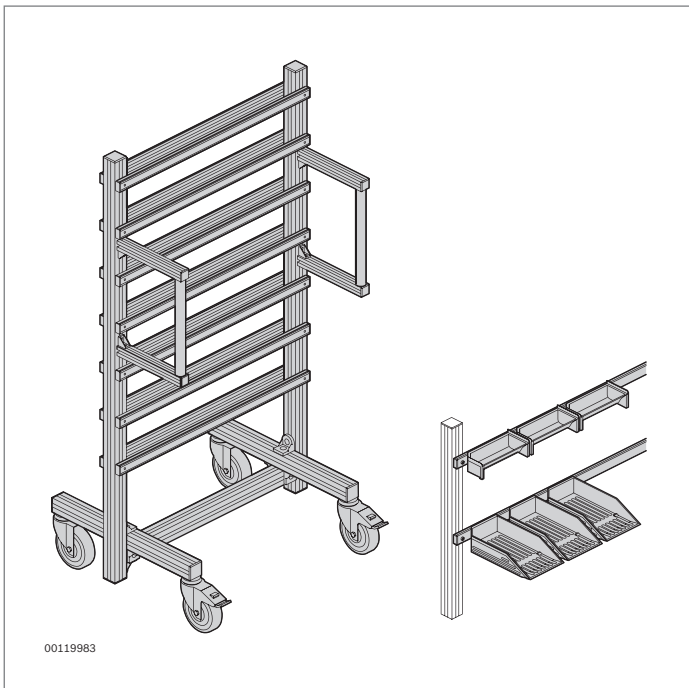
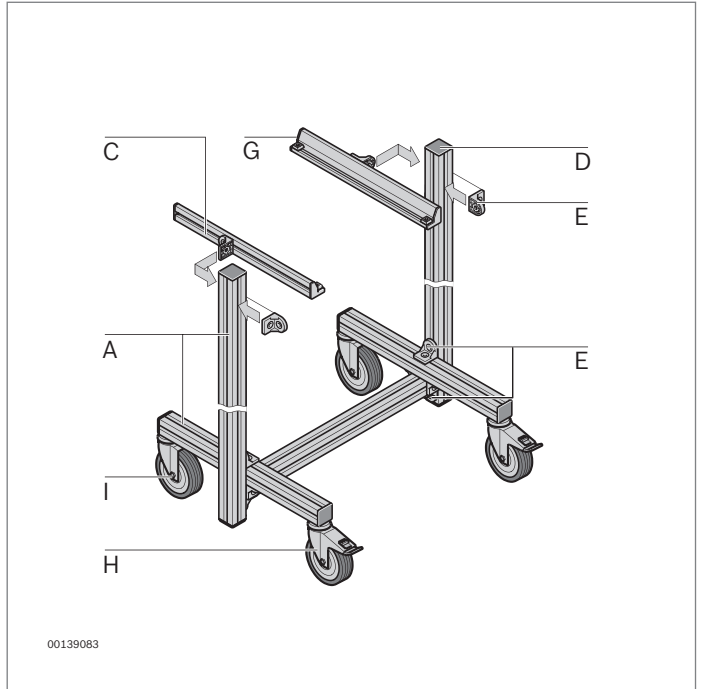
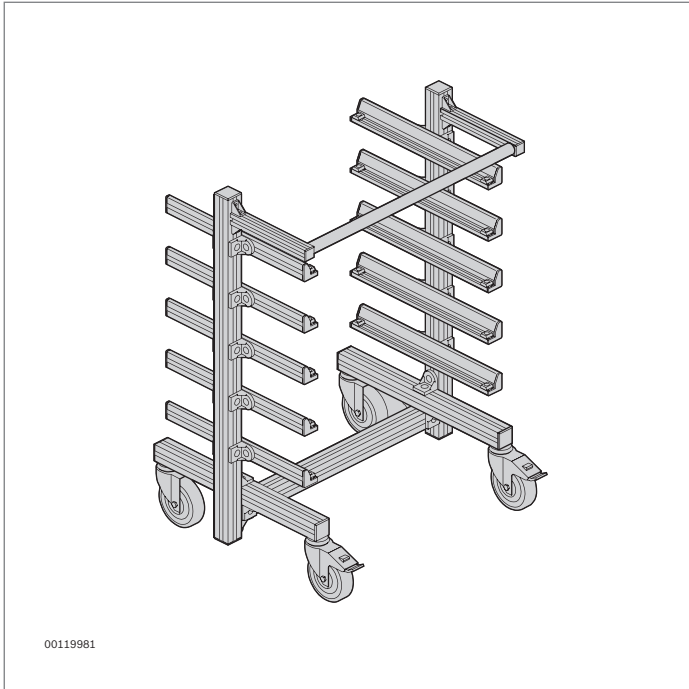
	L (mm)		ESD	No.
<b>A</b> 45x45L strut profile; material: Aluminum; anodized	50 ... 6070	1		<b>3 842 993 737/L</b>
<b>C</b> 30x30 2NVS; material: Aluminum; anodized	50 ... 6070	1		<b>3 842 993 706/L</b>
	6070	20		<b>3 842 557 209</b>
<b>F</b> R28x38 bracket, incl. fastening material for 8 mm slot; material: Diecast zinc				<b>3 842 515 547</b>
<b>H</b> 45x45 joint, incl. fastening material for 10 mm slot; material: Diecast aluminum				<b>3 842 538 687</b>
<b>I</b> Clamping lever				<b>3 842 538 607</b>
<b>J</b> Inner bracket for 8 mm slot; material: Steel, galvanized, transparent passivated		10		<b>3 842 535 577</b>
<b>K</b> 45x45 cover cap; material: PP, black		20		<b>3 842 548 753</b>
45x45 cover cap; material: PP, signal gray		100		<b>3 842 548 752</b>
<b>L</b> 30x30 cover cap; material: PP, black		20		<b>3 842 548 745</b>
30x30 cover cap; material: PP, signal gray		100		<b>3 842 548 744</b>

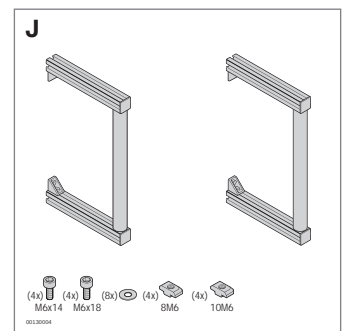
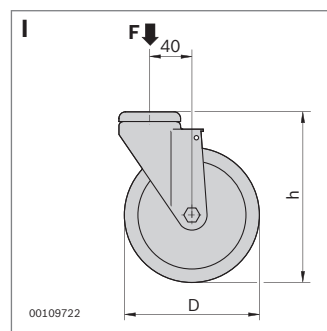
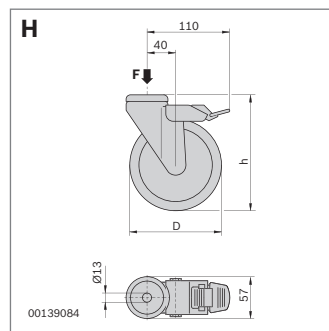
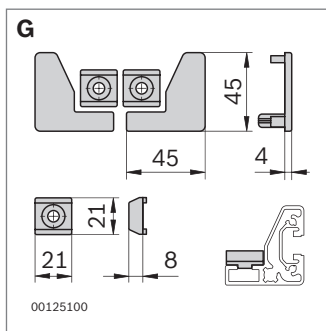
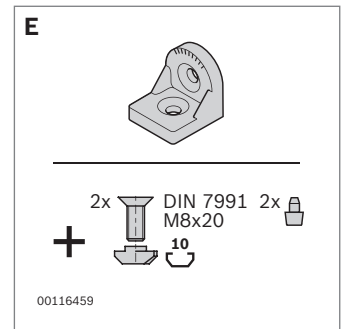
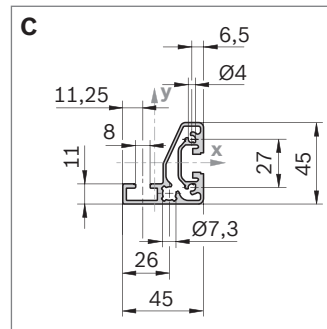
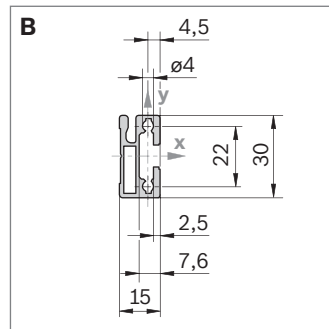
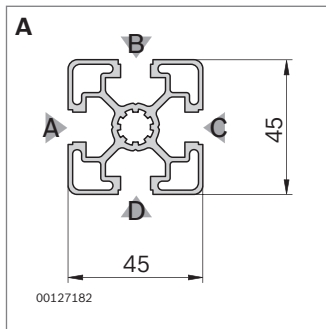
## 180° tool hanger self-assembly elements



	L (mm)		ESD No.
<b>X</b> 45x120 swivel bearing			<b>3 842 522 633</b>
<b>A</b> 45x90 swivel bearing			<b>3 842 554 410</b>
<b>B</b> 30x45C profile rail; material: Aluminum; anodized	50 ... 6070	1	<b>3 842 992 946</b>
	6070	20	<b>3 842 557 950</b>
<b>C</b> 30x45C end piece; material: PA, black		20	<b>3 842 554 711</b>
30x45C end piece; material: PA, signal gray		20	<b>3 842 554 710</b>
<b>D</b> Slide hanger for profile with 10 mm slot; material: POM			<b>3 842 218 953</b>
<b>E</b> R35x38 bracket, incl. fastening material for 10 mm slot; material: Diecast aluminum			<b>3 842 532 274</b>

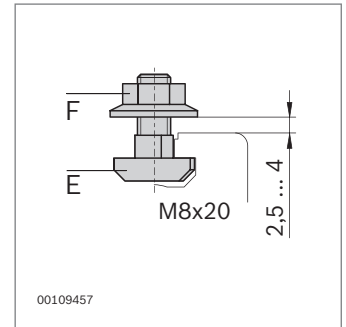
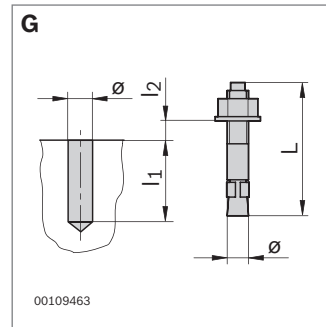
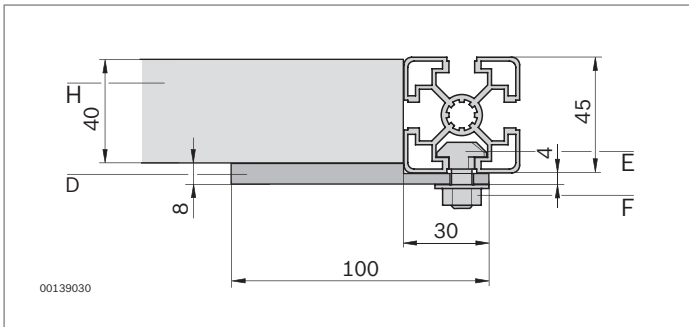
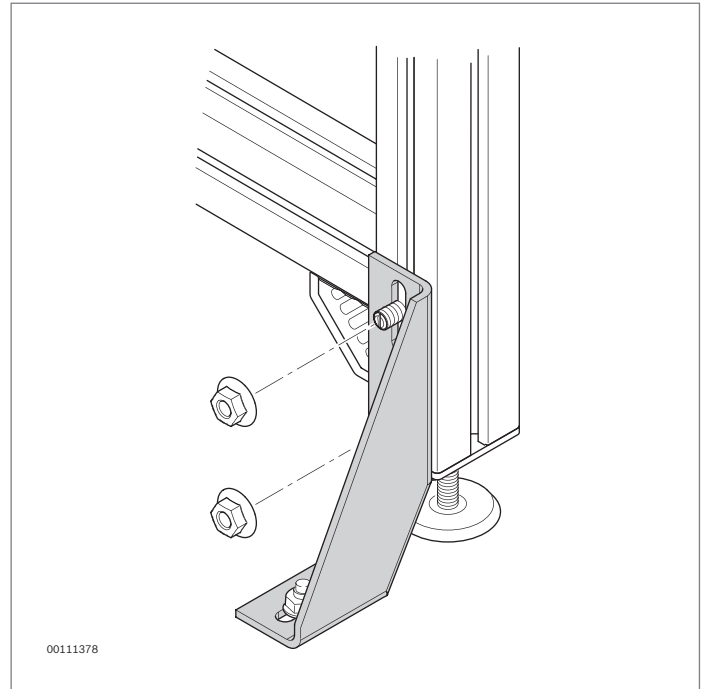
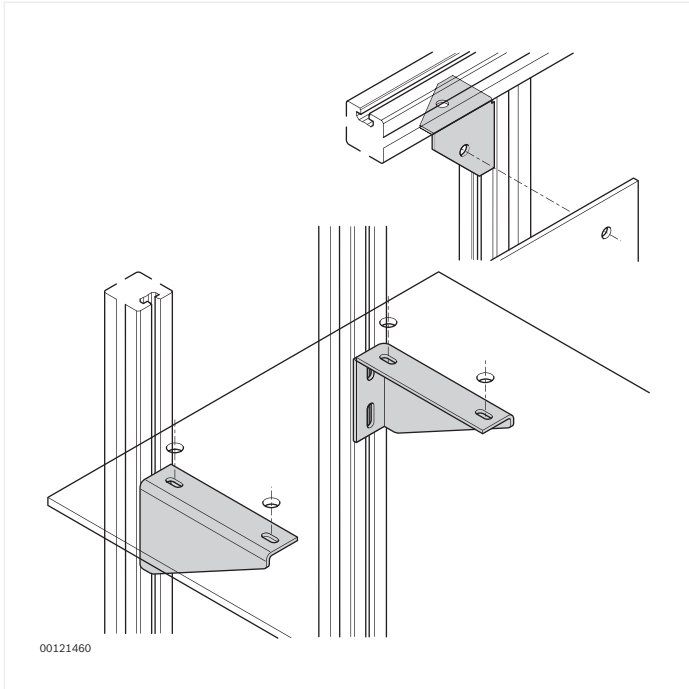
### Material shuttle self-assembly elements

















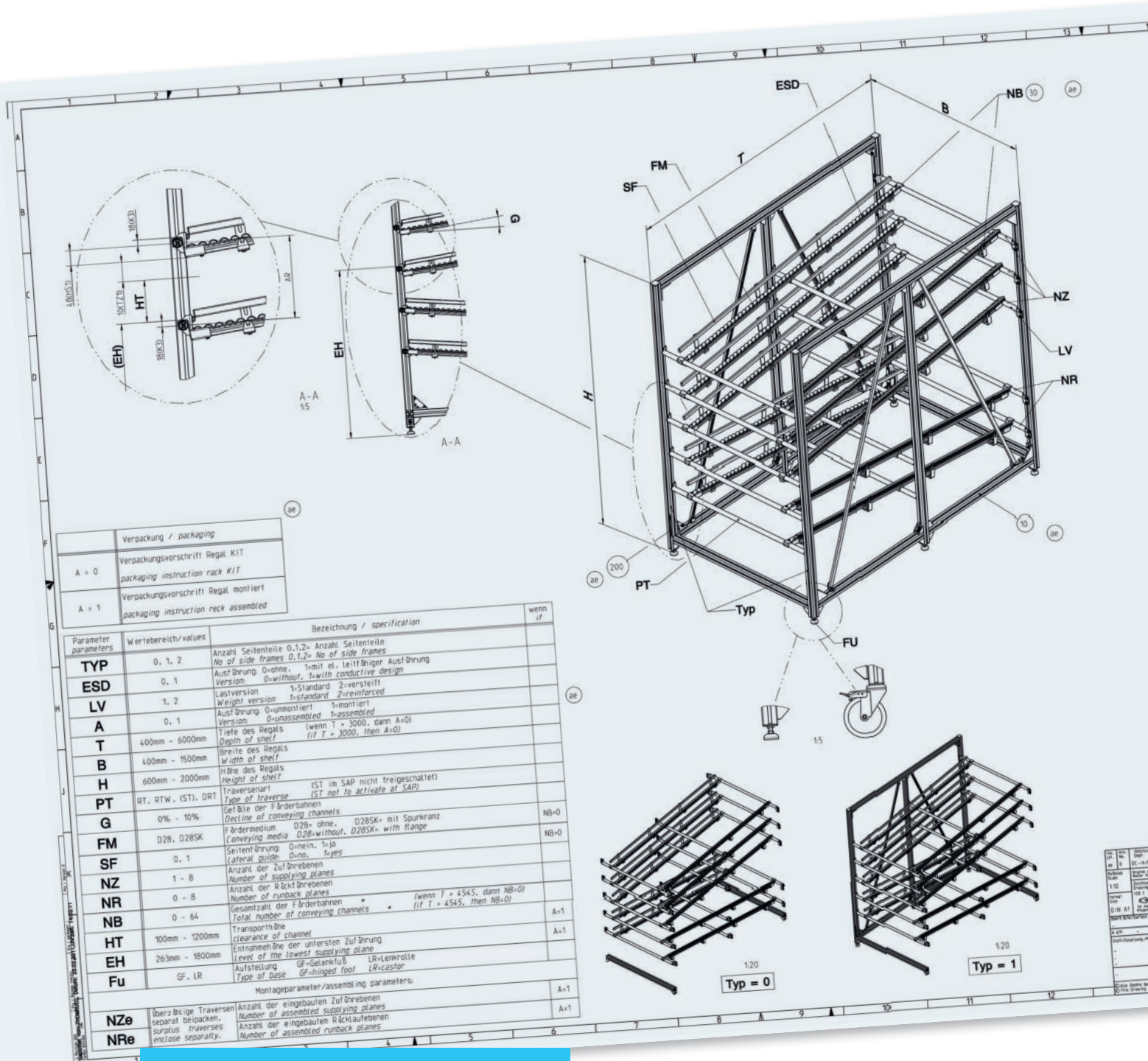
		L (mm)		ESD	No.
<b>A</b>	45x45L strut profile; material: Aluminum; anodized	50 ... 6070	1		<b>3 842 993 737/L</b>
		6070	20		<b>3 842 553 611</b>
<b>B</b>	Suspension profile; material: Aluminum; anodized	30 ... 3000	1		<b>3 842 993 411/L</b>
		3100	10		<b>3 842 537 679</b>
	Suspension profile; material: Aluminum, natural	30 ... 3000	1	⚠	<b>3 842 993 063/L</b>
		3000	10	⚠	<b>3 842 554 157</b>
<b>C</b>	Angle profile; material: Aluminum; anodized	30 ... 6070	1		<b>3 842 992 412/L</b>
		6070	20		<b>3 842 557 942</b>
<b>D</b>	45x45L cover cap; material: PP, black			20	⚠ <b>3 842 548 753</b>
		45x45L cover cap; material: PP, gray		20	<b>3 842 548 752</b>
<b>E</b>	R40x43 bracket, incl. fastening material for 10 mm slot; material: Diecast zinc				<b>3 842 518 424</b>
<b>F</b>	15x30 suspension profile cover cap; material: PP, black			20	⚠ <b>3 842 551 583</b>
		15x30 suspension profile cover cap; material: PP, gray		20	<b>3 842 551 582</b>
<b>G</b>	Parts kit for angle profile: Cover cap, stopper			20	<b>3 842 554 491</b>
		Parts kit, gray		20	<b>3 842 554 490</b>
<b>H</b>	D125 castor wheel with lock				<b>3 842 541 228</b>
<b>I</b>	D125 castor wheel				<b>3 842 541 236</b>
<b>J</b>	HG-305 handles		Set	⚠	<b>3 842 538 930</b>
<b>K</b>	M8 T-nut for 10 mm slot		100		<b>3 842 530 287</b>

## Supporting brackets, Foundation brackets, Table top supports



	L (mm)			ESD	No.
<b>A</b> Left supporting bracket, with fastening material for 10 mm slot; material: Sheet steel; powder-coated, RAL 7037	255				<b>3 842 536 119</b>
	335				<b>3 842 536 121</b>
	415				<b>3 842 536 123</b>
	495				<b>3 842 536 125</b>
<b>B</b> Right supporting bracket, with fastening material for 10 mm slot; material: Sheet steel; powder-coated, RAL 7037	255				<b>3 842 536 120</b>
	335				<b>3 842 536 122</b>
	415				<b>3 842 536 124</b>
	495				<b>3 842 536 126</b>
<b>C</b> Foundation bracket; material: Sheet steel; zinc-plated	160		20		<b>3 842 146 815</b>
	210		20		<b>3 842 146 848</b>
<b>D</b> Table top support, with fastening material for 10 mm slot		2			<b>3 842 521 677</b>
<b>E</b> M8x20 T-bolt			100		<b>3 842 528 715</b>
<b>F</b> M8 flange nut			100		<b>3 842 345 081</b>
<b>G</b> Floor dowel			100		<b>3 842 526 560</b>
<b>H</b> Table top					<b>3 842 998 250</b>

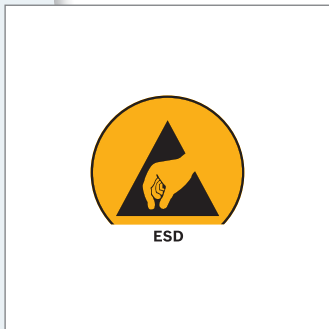
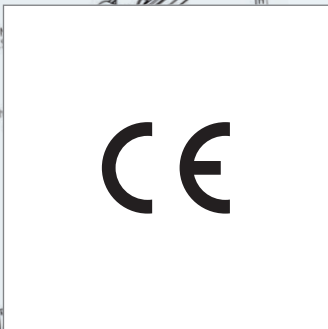
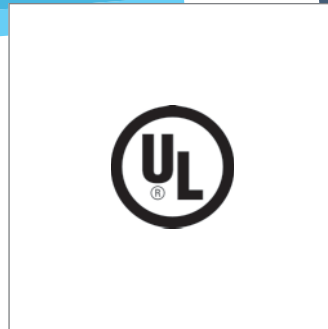
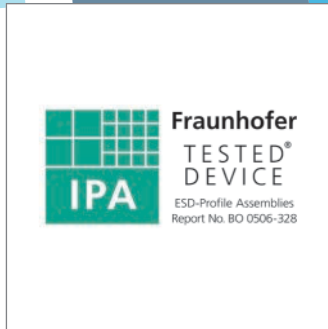
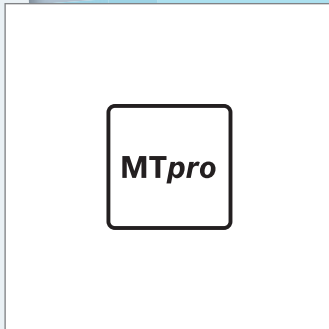
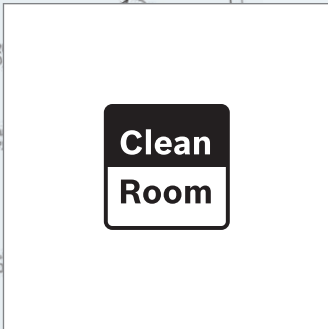
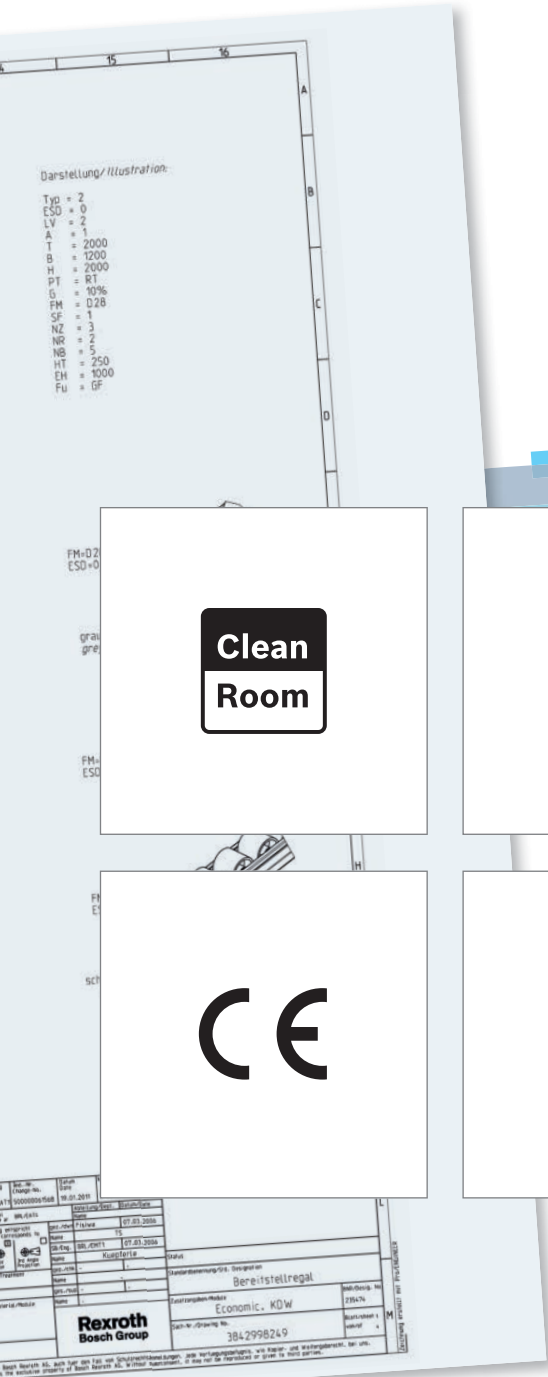




# Technical data

**Use these load specifications to configure your manual production systems quickly and safely.**

We believe in safety first! The load limits given in this section have been empirically tested in our labs under realistic work conditions. All of our products are developed in compliance with legal regulations and accepted engineering practices. Our flow rack systems, for example, fulfill the requirements of the Guidelines for Storage Systems issued by the relevant employer liability insurer.



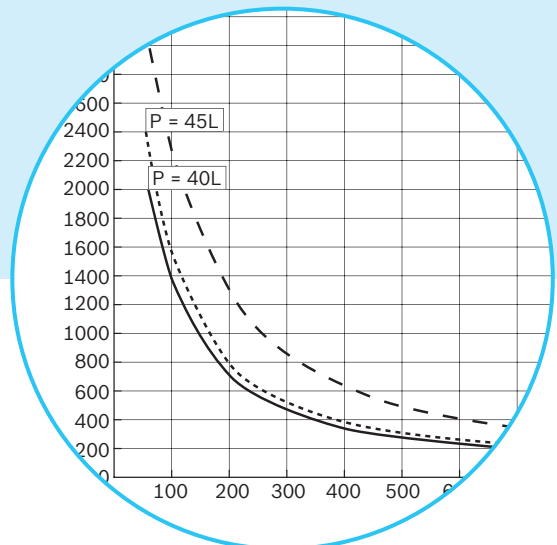
### OVERVIEW OF TECHNICAL DATA

- 13-3** Workstations and workstation accessories
- 13-11** Grab containers
- 13-12** Flow rack systems
- 13-18** EcoShape
- 13-20** Manual linking system (EcoFlow)
- 13-21** Material shuttles
- 13-23** Profiles

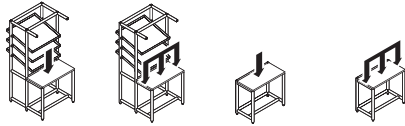
In addition, we commission independent institutes to carry out various tests. The ESD safety of our workstation system and our XClean, Lean and EcoFlow flow rack systems have all been analyzed by the Fraunhofer Institute for Manufacturing Engineering and Automation (IPA).

The IPA certificates of compliance with the requirements of ESD standards DIN EN 61340-5-1 and DIN EN 61340-4-1 are available for inspection at any time.

More in-depth technical information is provided in the operating and assembly instructions included with each product. These instructions are also available in MTpro or as Internet downloads.



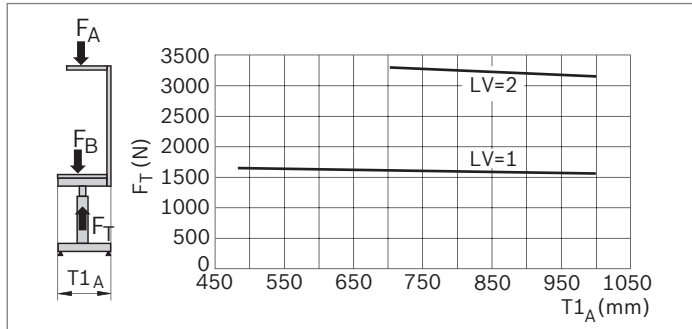
# Workstations and workstation accessories



BA (mm)	FU	F <sub>max</sub> (N)	F <sub>max</sub> (N)	F <sub>max</sub> (N)	F <sub>max</sub> (N)
≤ 1500	GF	2000	4000	2000	4000
	LR	2000	2400	2000	3000
> 1500	GF	1500	2000	1500	2000
	LR	1500	2000	1500	2000

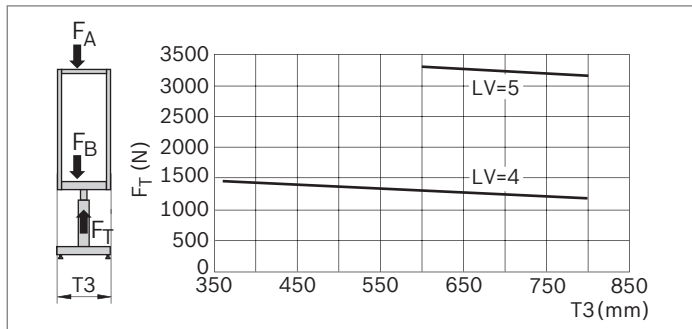
	Point load	<b>BA</b>	Width
	Distributed load	<b>FU</b>	Foot type
		<b>GF</b>	Leveling foot
		<b>LR</b>	Castor wheel

## Workstation module



Bearing load for height-adjustable workstation where BA = 1000 mm. The bearing load decreases as the width BA increases. Standard load version LV = 1; heavy load version LV = 2; H3 = 0

## Material supply module (accessory upright)



Bearing load for height adjustable material supply where BA = 1000 mm and H3 = 1200 mm. Standard load version LV = 4; heavy load version LV = 5

## Workstations

### Point and distributed loads for workstations

In configurable workstations, these values are dependent on the width (BA), foot design (FU) and workstation design. All values apply to desk and box type constructions.

**3 842 998 110** (page 2-13)

### Point and distributed loads for height-adjustable workstations

**3 842 998 350** (page 2-5)

The load carrying capacity of the workstation and material supply (accessory upright) modules is dependent on the selected load version (LV) and the respective design.

**F<sub>B</sub>** = Max. load (uniformly distributed load)

**F<sub>T</sub>** = Max. bearing load of base frame

**F<sub>A</sub>** = System weight of fixtures

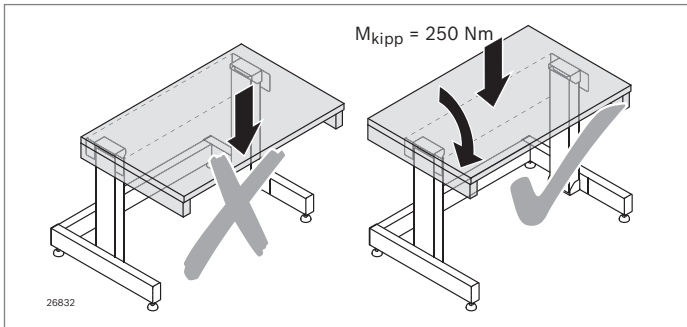
$$F_B = F_T - F_A$$

Load version type	Number of lifting modules:	Table	Accessory upright
LV = 1		2	0
LV = 2		4	0
LV = 3		2	2
LV = 4		4	2
LV = 5		2	4
LV = 6		4	4

The maximum load is calculated from the bearing load of the base frame minus the system weight of the fixtures (table top, brackets, material shelves, etc.).

In order to precisely determine the maximum load of your individual workstation system, please use *MTpro!*

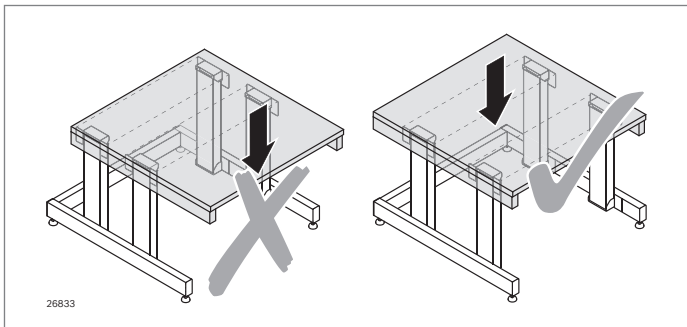
**Tilting moments**

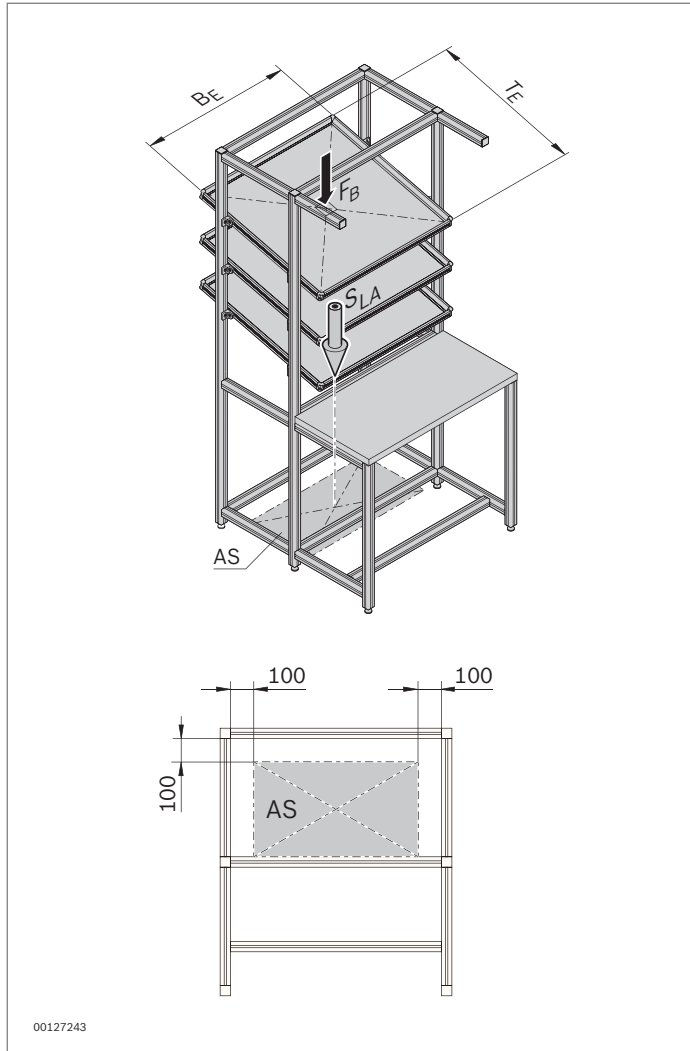


**Height-adjustable workstation**

**Lifting module**

**3 842 558 629** (page 2-7)





### Material shelf Basic

$S_{LA}$  Gravity vector

**AS** Permissible position of the line of action of the gravity vector  $S_{LA}$

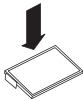
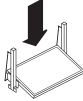
**3 842 998 183** (page 2-17)

**3 842 998 184** (page 2-17)

**3 842 998 155** (page 2-17)

Max. material shelf load									
Material shelf depth	$T_E$ (mm)	1220	1220	840	765	1000	1000	840	765
Material shelf width	$B_E$ (mm)	1480	840	1480	840	1000	840	1000	840
Plate, aluminum	$F_B$ (N)	700	700	700	1000				
Plate, PP, SB	$F_B$ (N)					250	280	280	360

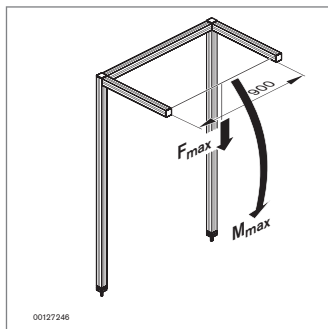
$F_B$  is a distributed load and may not occur as a point load.

	Economic	Basic
		
$F_{max}$ (N)	1000	1000

## Footrests

Maximum load of configurable footrests as well as standard footrests.

- 3 842 998 256** (page 2-19)
- 3 842 538 771** (page 2-19)
- 3 842 538 772** (page 2-19)
- 3 842 998 257** (page 2-20)
- 3 842 519 735** (page 2-20)
- 3 842 537 737** (page 2-20)
- 3 842 538 409** (page 2-20)
- 3 842 515 160** (page 2-20)
- 3 842 538 098** (page 2-20)

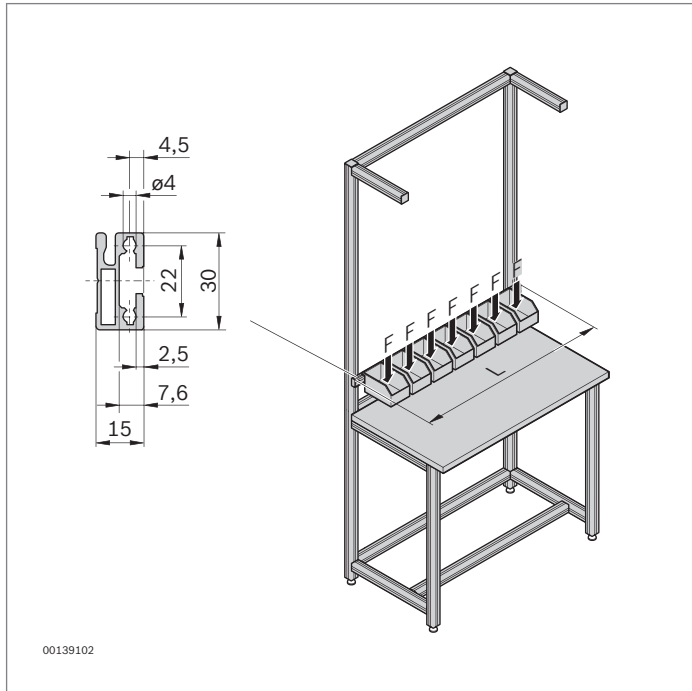


$F_{max}$ (N)	250
$M_{max}$ (Nm)	150

## Workstation accessories

### Standard strut extension P = 45x45L

- 3 842 519 530** (page 2-15)



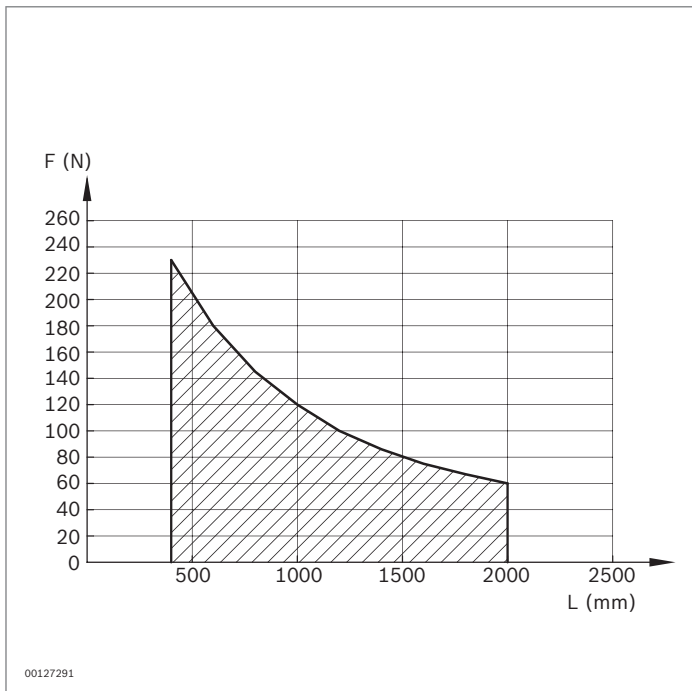
**15x30 suspension profile**

**3 842 993 411/L** (pages 12-11/12, 12-15/16, 13-23)

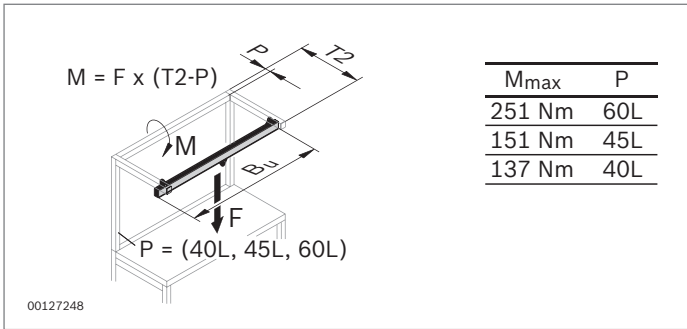
**3 842 537 679** (pages 12-11/12, 12-15/16, 13-23)

**3 842 993 063/L** (pages 12-11/12, 12-15/16, 13-23)

**3 842 554 157** (pages 12-11/12, 12-15/16, 13-23)

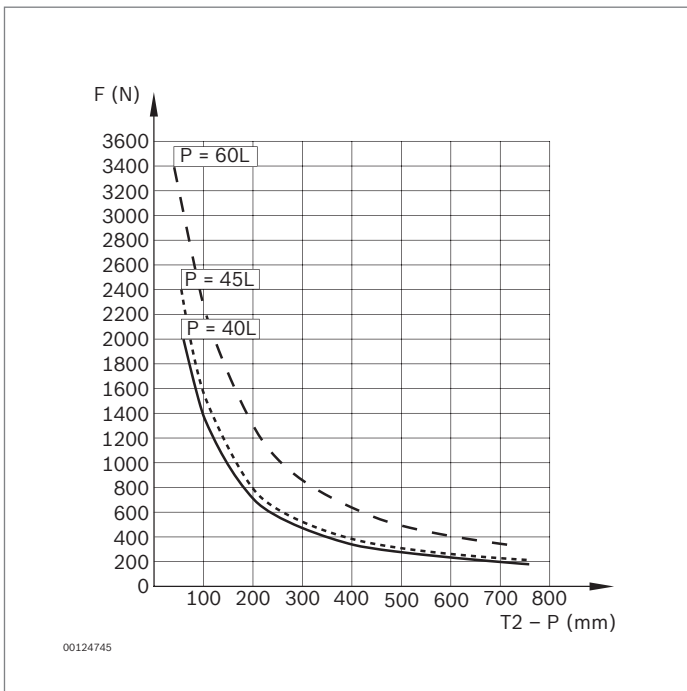


**Diagram 1: Permissible load for the suspension profile**



**Workstation hanger**

Without accessory upright, with accessory upright,  
with reinforced strut extension  
(page 12-10)



**Example for determining  $F_{max}$**

Determination of load for the strut extension:

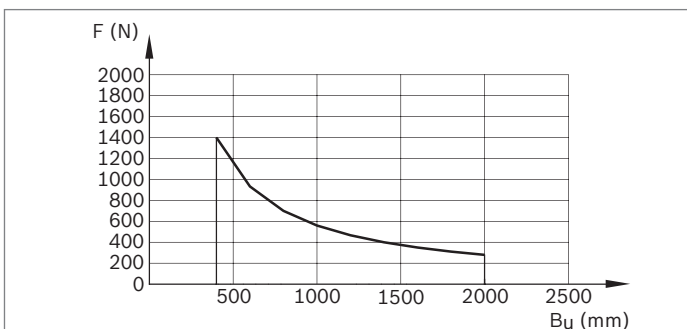
P = 45 mm  
T2 = 400 mm  
Diag. 2 → F = 380 N

Determination of load for hanger:

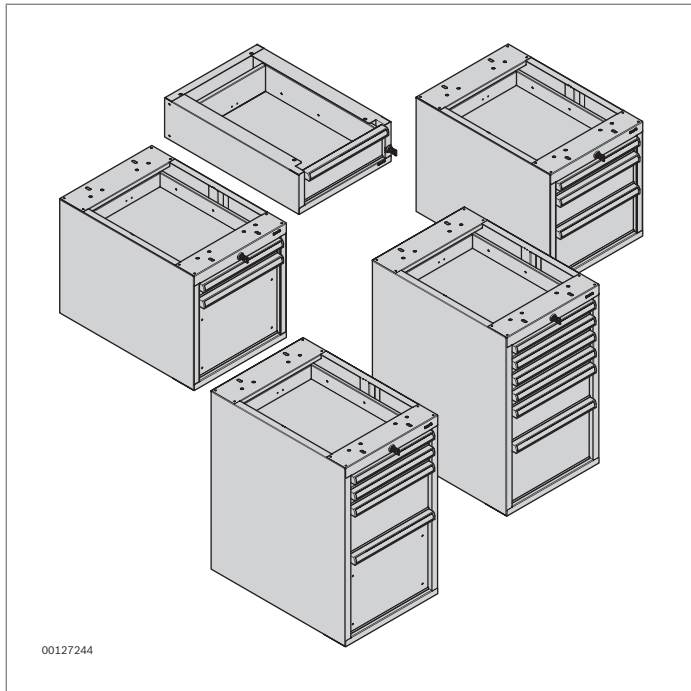
B<sub>U</sub> = 1000 mm  
Diag. 3 → F = 580 N

The maximum permissible load  $F_{max}$  is the lower of the two load values.  $F_{max} = 380$  N

**Diagram 2: Permissible load for the strut extension**



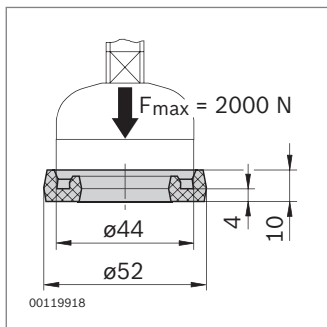
**Diagram 3: Permissible load for the hanger**



**Base drawer**  
**Drawer cabinet**  
**Containers**

- 3 842 546 533** (page 2-45)
- 3 842 546 534** (page 2-46)
- 3 842 546 535** (page 2-46)
- 3 842 546 538** (page 2-46)
- 3 842 546 539** (page 2-46)
- 3 842 546 540** (page 2-46)
- 3 842 547 886** (page 2-46)
- 3 842 547 887** (page 2-46)
- 3 842 559 392** (page 2-46)

Load per drawer: 350 N  
 Total load for cabinet: 800 N  
 Total load for container: 1300 N

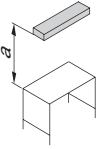
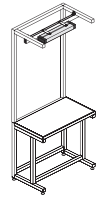
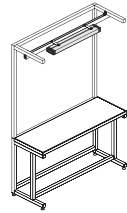
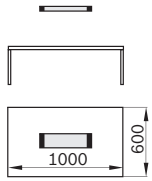
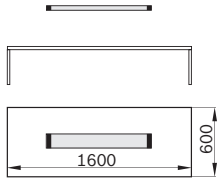


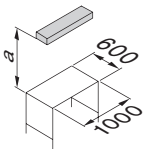
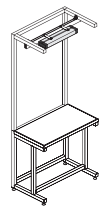
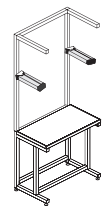
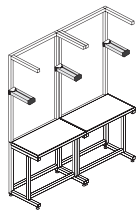
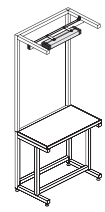
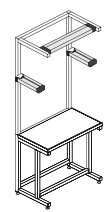
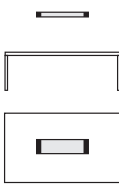
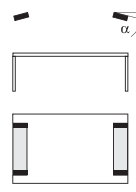
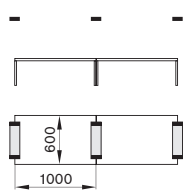
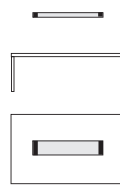
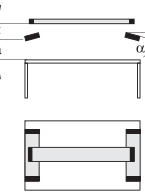
<b>F<sub>max</sub> (N)</b>	<b>2000</b>
----------------------------	-------------

**Damping rings**

- 3 842 521 817** (page 2-54)

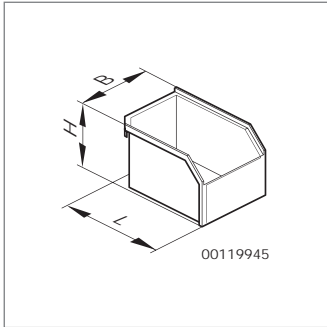
**System lamps SL LED economic and SL LED basic**











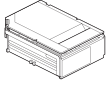





SL LED economic - Illuminance depending on arrangement		
	SL 12 economic	SL 12 economic wide
		
		
a (m)	$\bar{E}$ (lx)	$\bar{E}$ (lx)
0.75		
1.00	980	730
1.25	700	550
1.50	520	430
2.00	310	270

SL LED basic - Illuminance depending on arrangement								
	SL 12 basic	SL 12 basic Duo		SL 12 basic	SL 24 basic	SL basic Tri-Light		
								
								
a (m)	$\bar{E}$ (lx)	$\alpha$ (°)	$\bar{E}$ (lx)	$\bar{E}$ (lx)	$\bar{E}$ (lx)	x (m)	$\alpha$ (°)	$\bar{E}$ (lx)
0.75	1100	20	1660	1390	2270	0.25	20	3130
1.00	710	20	1150	1060	1470	0.25	20	2160
						0.25	15	1560
1.25	490	20	830	820	1010	0.25	15	1170
1.50	350	15	620	660	730			
2.00	200	15	380	450	420			

 Mean  $\bar{E}$  of the illuminance on the working surface (new values, planning factor 0.8)

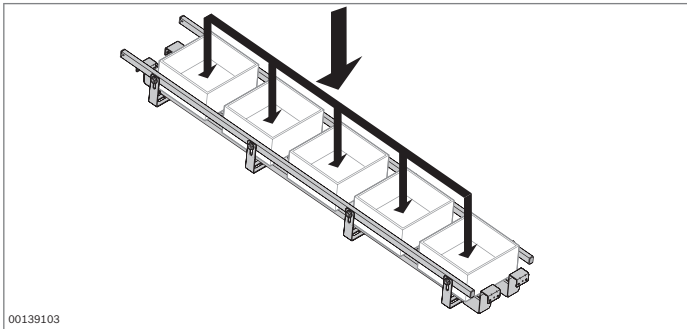
## Grab containers



	Type	Format	Volume	ESD No.	Static load limit				
					Container mount (kg)	Suspension profile (kg)			
		W x H x L (mm)	(ccm)						
<b>GB-Axxxx cover</b> Material: PC Min./max. ambient temperature: -40 °C / +115 °C Resistant to diluted acidic and caustic materials, alcohol (except for methanol), grease, oils, glycol, water		<b>GB-A0805</b>	77 x 13 x 173	–	<b>3 842 344 756</b>	–	–		
						<b>3 842 346 286</b>	–	–	
		<b>GB-A1205</b>	117 x 13 x 173	–	<b>3 842 344 757</b>	–	–		
						<b>3 842 346 287</b>	–	–	
		<b>GB-A1210</b>	117 x 32 x 173	–	<b>3 842 344 758</b>	–	–		
<b>ESD version</b> Material: ABS-CF Min./max. ambient temperature: -40 °C / +70 °C Resistant to diluted acidic and caustic materials, alcohol (except for methanol), grease, oils, glycol, water		<b>GB-A1710</b>	167 x 32 x 245	–	<b>3 842 344 759</b>	–	–		
						<b>3 842 346 289</b>	–	–	
						<b>3 842 557 478*</b>	–	–	
<b>GB-Sxx grab tray</b> <b>GB-xxxx grab container</b> <b>G-Zxx grab ledge</b> Material: ABS Min./max. ambient temperature: -40 °C / +70 °C Resistant to mildly acidic and caustic materials, alcohols, greases, oils, water		<b>GB-S08</b>	82 x 50 x 86	150	<b>3 842 344 764</b>	11	17		
						<b>3 842 346 294</b>	6	10	
		<b>GB-S12</b>	123 x 50 x 86	240	<b>3 842 344 765</b>	11	19		
						<b>3 842 346 295</b>	6	11	
		<b>GB-S17</b>	173 x 50 x 86	360	<b>3 842 344 766</b>	11	21		
						<b>3 842 346 296</b>	6	12	
		<b>GB-0805</b>	82 x 50 x 173	370	<b>3 842 344 750</b>	10	26		
						<b>3 842 346 280</b>	6	15	
		<b>GB-1205</b>	123 x 50 x 173	600	<b>3 842 344 751</b>	10	26		
						<b>3 842 346 281</b>	6	15	
		<b>ESD version</b> Material: ABS-CF Min./max. ambient temperature: -40 °C / +70 °C Resistant to diluted acidic and caustic materials, alcohol (except for methanol), grease, oils, glycol, water		<b>GB-1210</b>	123 x 100 x 173	1370	<b>3 842 344 752</b>	10	26
								<b>3 842 346 282</b>	6
<b>GB-1710</b>	173 x 100 x 245			3050	<b>3 842 344 753</b>	13	30		
						<b>3 842 346 283</b>	8	18	
						<b>3 842 555 685*</b>	8	18	
<b>ESD version</b> Material: ABS-CF Min./max. ambient temperature: -40 °C / +70 °C Resistant to diluted acidic and caustic materials, alcohol (except for methanol), grease, oils, glycol, water		<b>GB-Z08</b>	90 x 54 x 277	690	<b>3 842 344 760</b>	10	30		
						<b>3 842 346 290</b>	6	18	
		<b>GB-Z12</b>	131 x 54 x 277	1050	<b>3 842 344 761</b>	6	23		
					<b>3 842 346 291</b>	3	13		

\* Red version

## Flow rack systems



### XLean, Lean, EcoFlow flow rack systems

#### Max. load per track

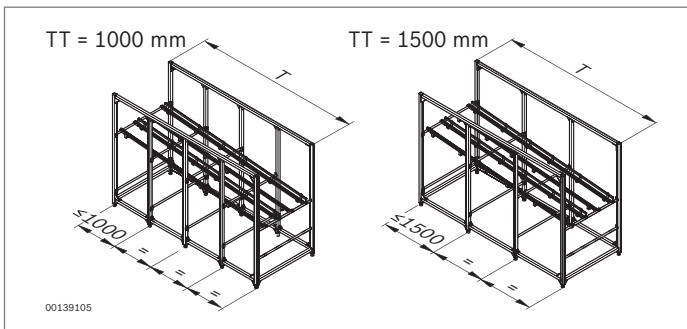
$$F_{\Sigma} = F_R + F_B + F_T$$

$F_{\Sigma}$  is a distributed load and may not occur as a point load.

$F_R$  = Weight of roller tracks

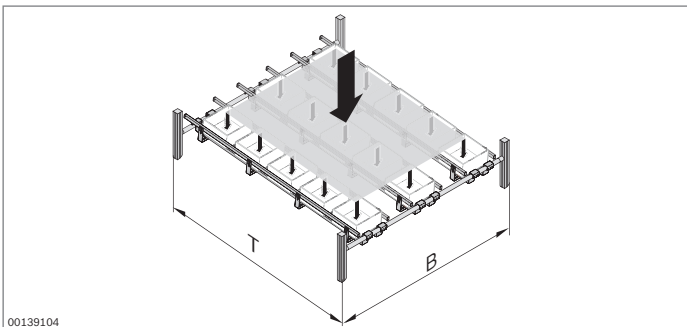
$F_B$  = Weight of containers

$F_T$  = Weight of stored parts



	TT = 1000 mm	TT = 1500 mm
	$F_{\Sigma \max}^*$	$F_{\Sigma \max}^*$
<b>XLean</b>	650 N/1000 mm	450 N/1000 mm
<b>Lean</b>	1300 N/1000 mm	900 N/1000 mm
<b>EcoFlow</b>	2100 N/1000 mm	1400 N/1000 mm

\* Max. permissible load  $F_{\Sigma \max}$  per 1000 mm of conveyor track



#### Max. load per shelf

$$F_{\Sigma} = F_R + F_B + F_T$$

$F_{\Sigma}$  is a distributed load and may not occur as a point load.

$F_R$  = Weight of roller tracks

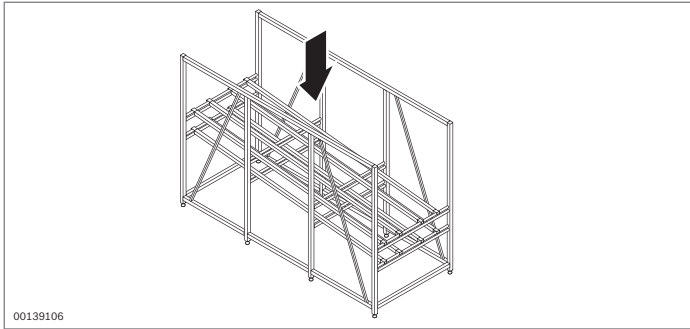
$F_B$  = Weight of containers

$F_T$  = Weight of stored parts

TT = 1000 mm	TT = 1500 mm	B ≤ 1000 mm			1000 < B ≤ 1500 mm		
		PT = RT PT = RTW	PT = DRT	PT = ST	PT = RT PT = RTW	PT = DRT	PT = ST
T (mm)	T (mm)	$F_{\Sigma \max}^{1)}$	$F_{\Sigma \max}^{1)}$	$F_{\Sigma \max}^{1)}$	$F_{\Sigma \max}^{1)}$	$F_{\Sigma \max}^{1)}$	$F_{\Sigma \max}^{1)}$
T ≤ 1000	T ≤ 1500	2000 N	12000 N	6000 N	1000 N	6000 N	3000 N
1000 < T ≤ 2000	1500 < T ≤ 3000	3000 N	18000 N	9000 N	1500 N	9000 N	4500 N
2000 < T ≤ 3000	3000 < T ≤ 4500	4000 N	20000 N <sup>2)</sup>	12000 N	2000 N	12000 N	6000 N
3000 < T ≤ 4000	4500 < T ≤ 6000	5000 N	20000 N <sup>2)</sup>	15000 N	2500 N	15000 N	7500 N
4000 < T ≤ 5000	–	6000 N	20000 N <sup>2)</sup>	18000 N	3000 N	18000 N	9000 N
5000 < T ≤ 6000	–	7000 N	20000 N <sup>2)</sup>	20000 N <sup>2)</sup>	3500 N	20000 N <sup>2)</sup>	10500 N

<sup>1)</sup> Max. permissible load  $F_{\Sigma \max}$  per shelf

<sup>2)</sup> Limited to  $F_{\Sigma} = 20000$  N per flow rack



**Max. load per flow rack**

$$F_{\Sigma} = F_R + F_B + F_T$$

$F_{\Sigma}$  is a distributed load and may not occur as a point load.

$F_R$  = Weight of roller tracks

$F_B$  = Weight of containers





$F_T$  = Weight of stored parts

**3 842 998 249** (page 5-5)





**3 842 998 332** (page 5-7)

**3 842 998 322** (page 5-9)

**Max. permissible load per flow rack**

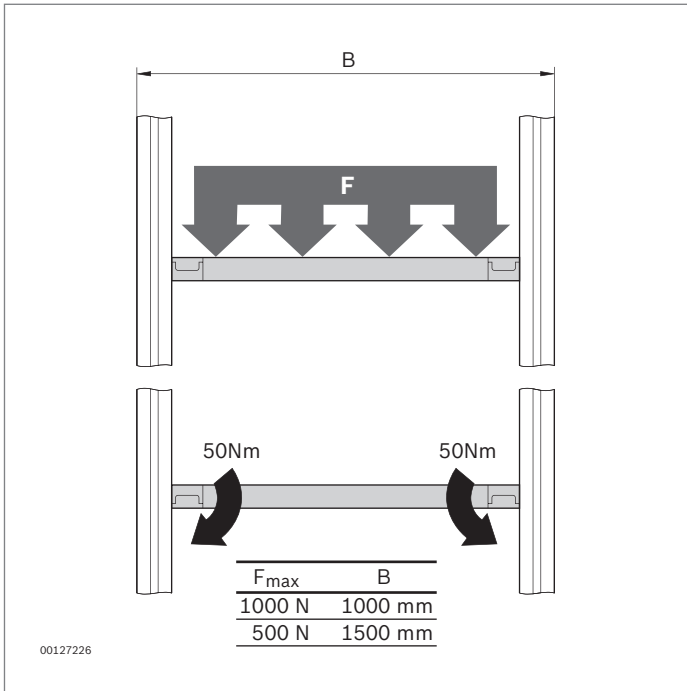
Standard load version (LV = 1)		Two side elements (Type 2)		One side element (Type 1)	
<b>TT = 1000</b>	<b>TT = 1500</b>				
<b>T (mm)</b>	<b>T (mm)</b>	<b>FU = LR</b>	<b>FU = GF</b>	<b>FU = LR</b>	<b>FU = GF</b>
		<b><math>F_{\Sigma \max}^{1)}</math></b>	<b><math>F_{\Sigma \max}^{1)}</math></b>	<b><math>F_{\Sigma \max}^{1)}</math></b>	<b><math>F_{\Sigma \max}^{1)}</math></b>
T ≤ 1000	T ≤ 1500	3600 N	4000 N	1800 N	2000 N
1000 < T ≤ 2000	1500 < T ≤ 3000	4000 N	4000 N	2000 N	2000 N
2000 < T ≤ 3000	3000 < T ≤ 4500	4000 N	4000 N	2000 N	2000 N
3000 < T ≤ 4000	4500 < T ≤ 6000	4000 N	4000 N	2000 N	2000 N
4000 < T ≤ 5000	-	4000 N	4000 N	2000 N	2000 N
5000 < T ≤ 6000	-	4000 N	4000 N	2000 N	2000 N

<sup>1)</sup> Max. permissible load  $F_{\Sigma \max}$  per flow rack; standard load version (LV = 1)

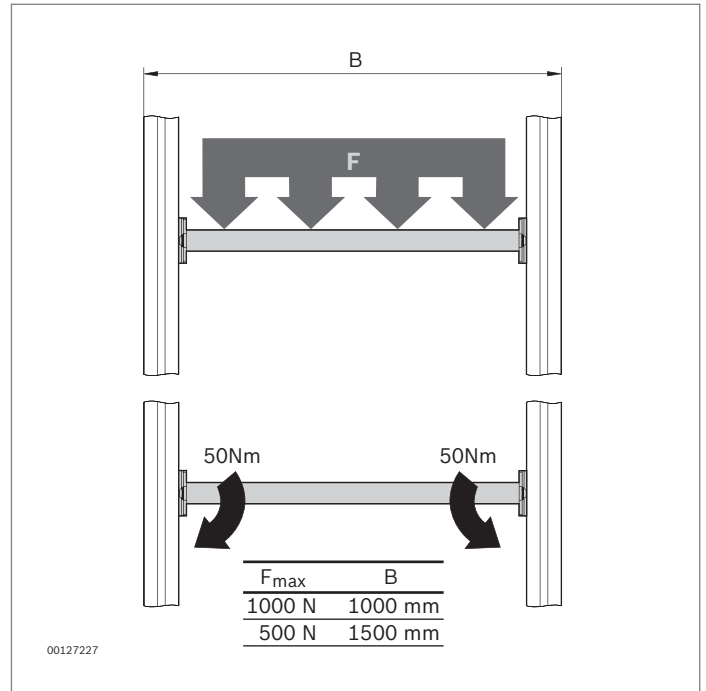
Reinforced load version (LV = 2)		Two side elements (Type 2)		One side element (Type 1)	
<b>TT = 1000</b>	<b>TT = 1500</b>				
<b>T (mm)</b>	<b>T (mm)</b>	<b>FU = LR</b>	<b>FU = GF</b>	<b>FU = LR</b>	<b>FU = GF</b>
		<b><math>F_{\Sigma \max}^{2)}</math></b>	<b><math>F_{\Sigma \max}^{2)}</math></b>	<b><math>F_{\Sigma \max}^{2)}</math></b>	<b><math>F_{\Sigma \max}^{2)}</math></b>
T ≤ 1000	T ≤ 1500	3600 N	20000 N	1800 N	10000 N
1000 < T ≤ 2000	1500 < T ≤ 3000	4000 N	20000 N	2000 N	10000 N
2000 < T ≤ 3000	3000 < T ≤ 4500	4000 N	20000 N	2000 N	10000 N
3000 < T ≤ 4000	4500 < T ≤ 6000	4800 N	20000 N	2400 N	10000 N
4000 < T ≤ 5000	-	5600 N	20000 N	2800 N	10000 N
5000 < T ≤ 6000	-	6400 N	20000 N	3200 N	10000 N

<sup>2)</sup> Max. permissible load  $F_{\Sigma \max}$  per flow rack; reinforced load version (LV = 2)

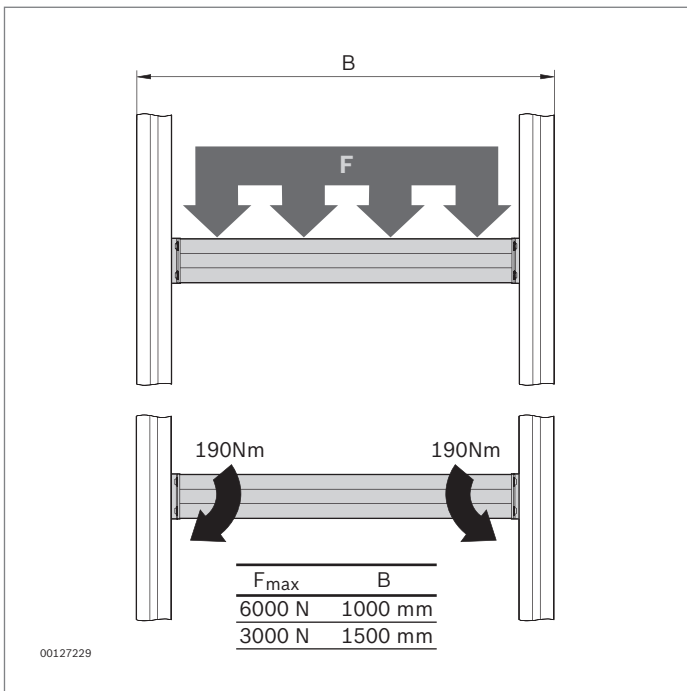
**Cross ties**



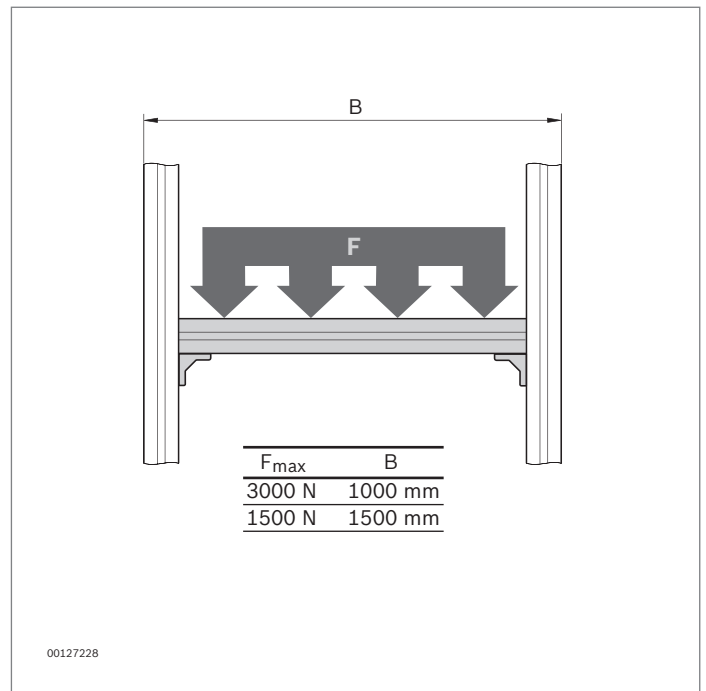
RT tubular cross tie  
(page 5-25)



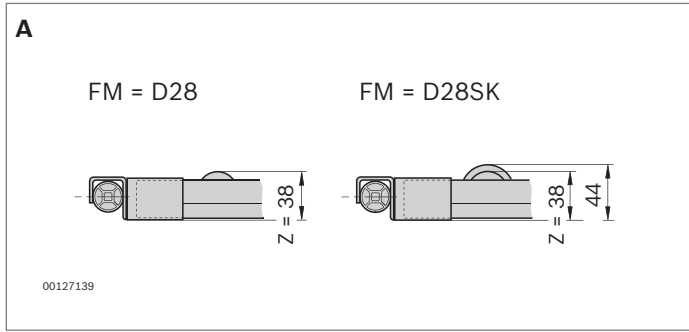
Tubular cross tie with RTW bracket  
(page 5-25)



Double tubular cross tie with DRT bracket  
(page 5-25)



ST profile cross tie  
(page 5-25)

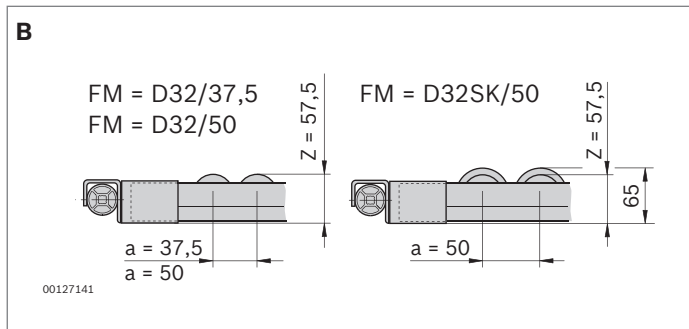


## Conveyor tracks

### **XLean conveyor track with rail holder (A)**

- ▶ Rollers with  $\varnothing$  28 mm with and without roller flange.

**3 842 998 196** (page 5-11)

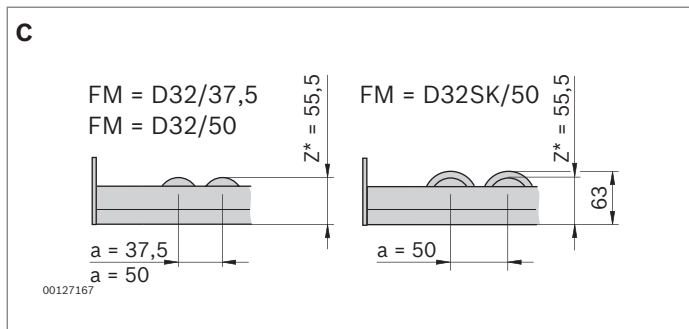


### **Lean conveyor track with rail holder (B)**

- ▶ Rollers with  $\varnothing$  32 mm with and without roller flange.

**3 842 998 381** (page 5-16)

**3 842 998 382** (page 5-16)

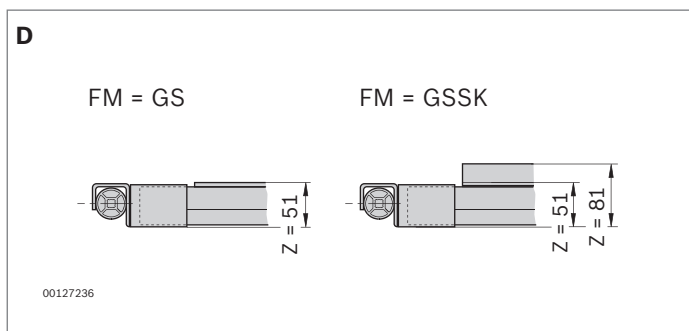


### **Lean conveyor track with stop plate (C)**

- ▶ Rollers with  $\varnothing$  32 mm with and without roller flange.

**3 842 998 383** (page 5-18)

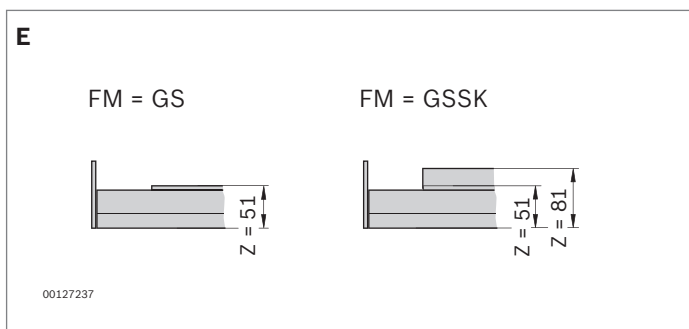
**3 842 998 384** (page 5-18)



### **Lean conveyor track with rail holder (D)**

- ▶ Slide rail with and without roller flange.

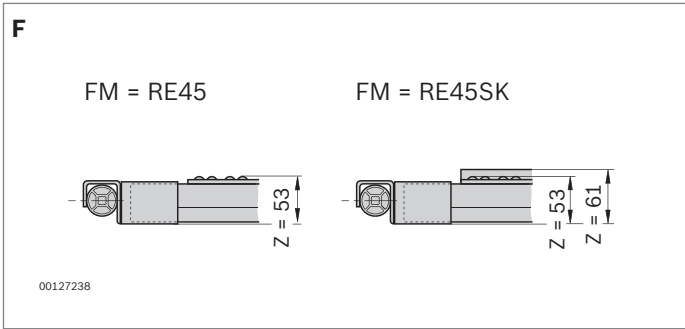
**3 842 998 387** (page 5-16)



### **Lean conveyor track with stop plate (E)**

- ▶ Slide rail with and without roller flange.

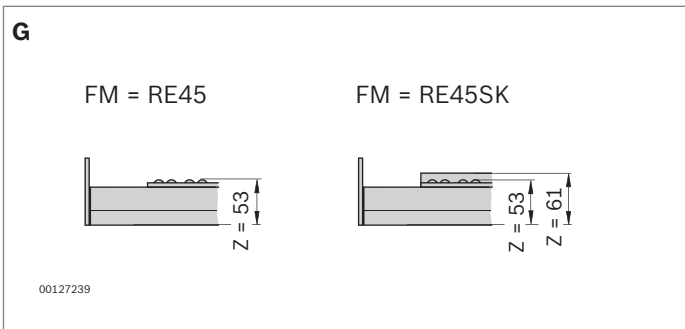
**3 842 998 388** (page 5-18)



**Lean conveyor track with rail holder (F)**

► Roller elements with and without roller flange.

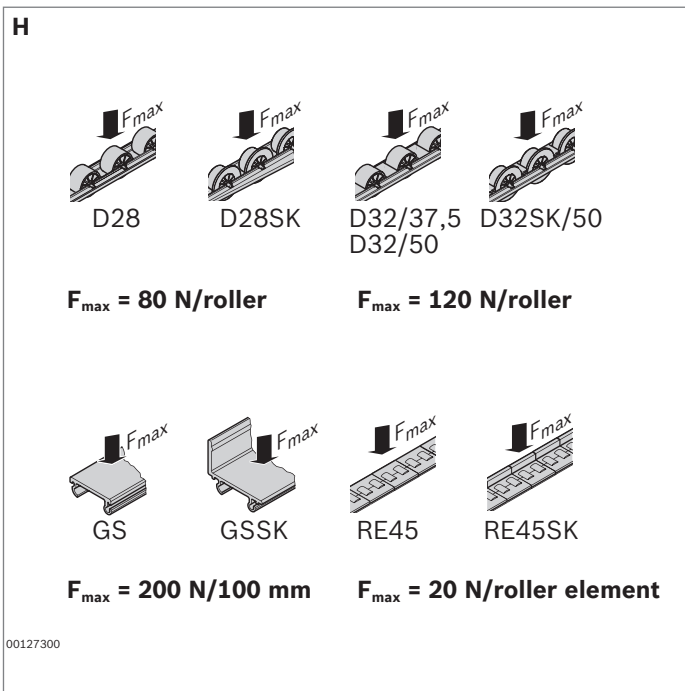
**3 842 998 385** (page 5-16)



**Lean conveyor track with stop plate (G)**

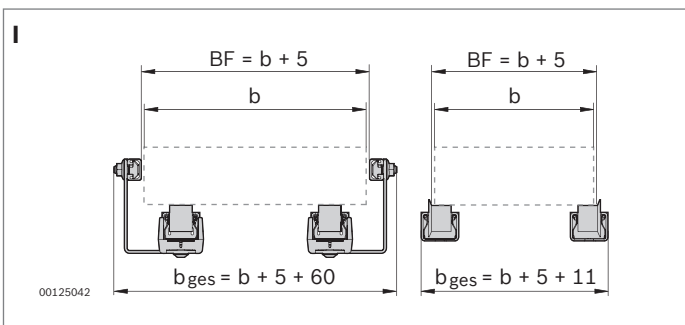
► Roller elements with and without roller flange.

**3 842 998 386** (page 5-18)



**Conveyor media (H)**

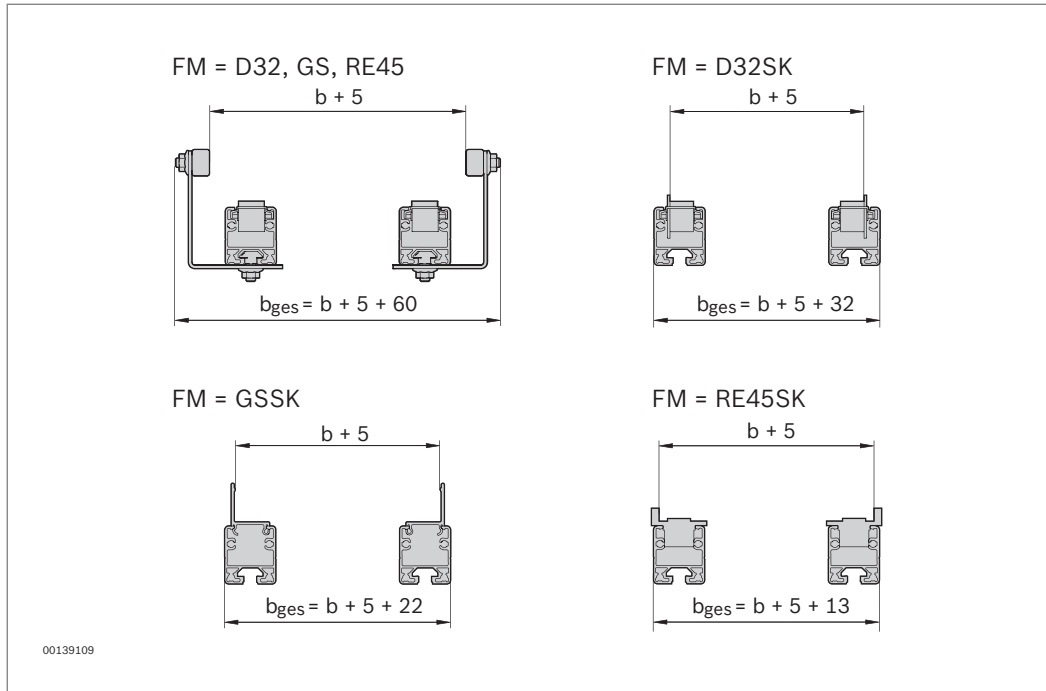
D28, D28SK (page 5-12)  
 D32/37,5, D32/50, D32SK/50, GS, GSSK  
 (pages 5-15, 5-17, 5-19, 5-20)  
 RE45, RE45SK (pages 5-15, 5-17, 5-20)



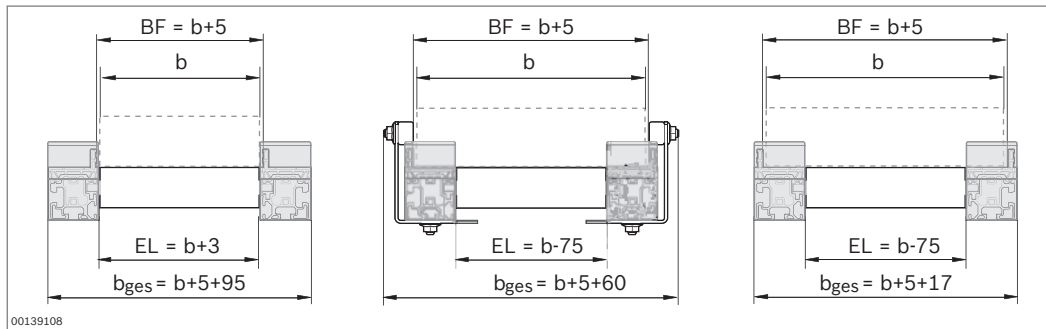
**Conveyor tracks with and without lateral guide (I)**

**XLean conveyor track**

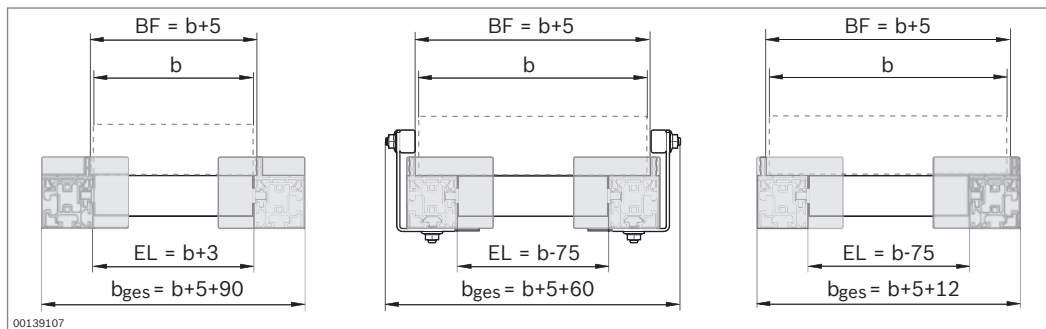
**Lean conveyor track**



**EcoFlow conveyor track with rail holder**



**EcoFlow conveyor track with stop plate**



EL = Roller length

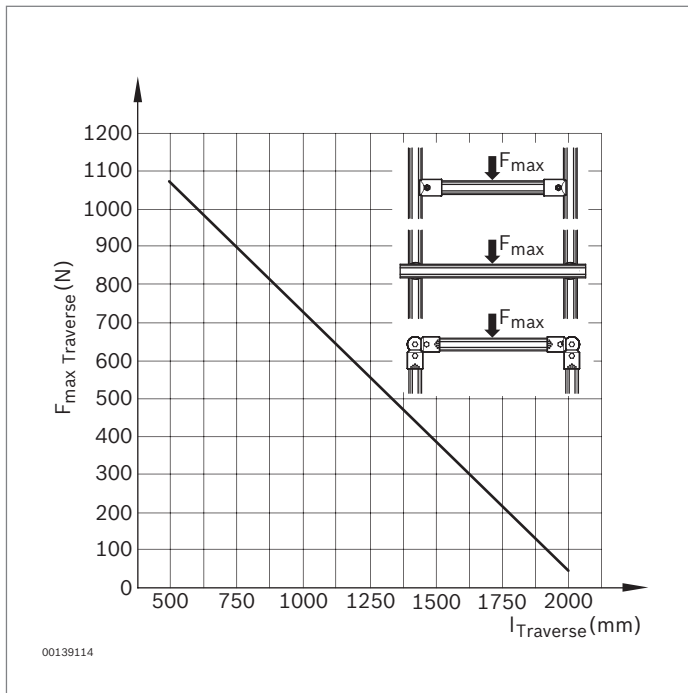
# EcoShape

The specified tightening and loading limit values were determined as an example in (dry) trials.

Safety factors and building regulations in accordance with the law and accepted engineering practices must be observed!

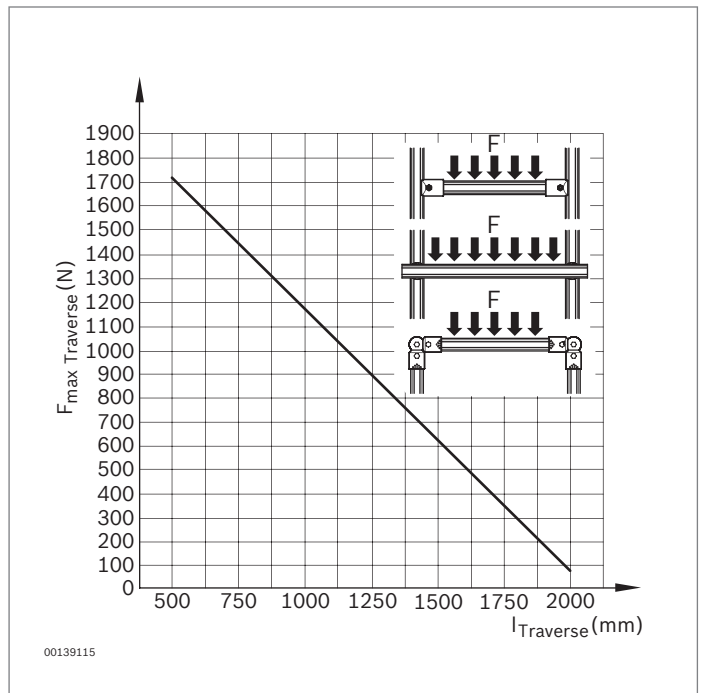
## D28L cross tie – permissible point load in the center

Connector: 90° connector, cross connector, corner bracket



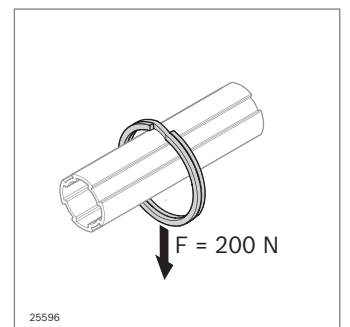
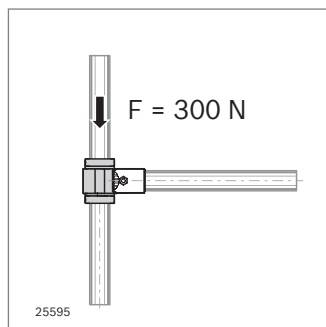
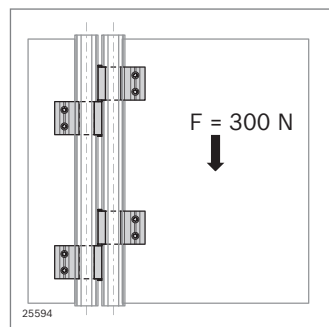
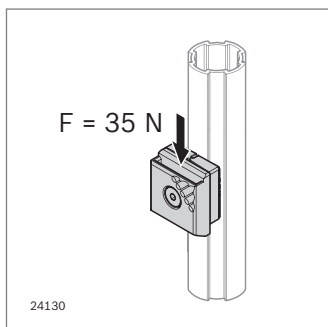
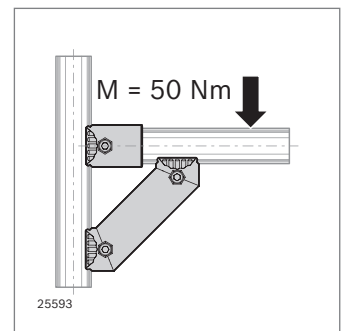
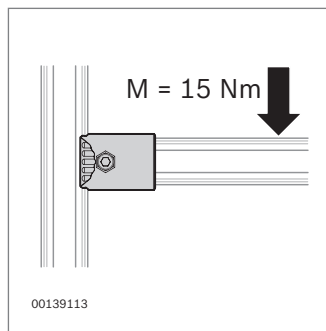
## D28L cross tie – permissible section load

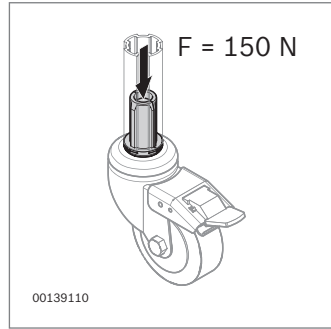
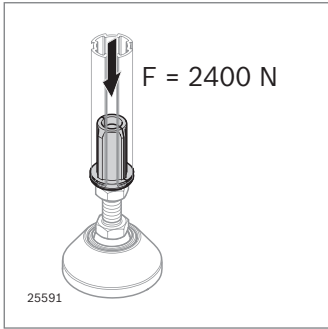
Connector: 90° connector, cross connector, corner bracket



## Connector

Static load limit values of the connection (beginning of plastic deformation)

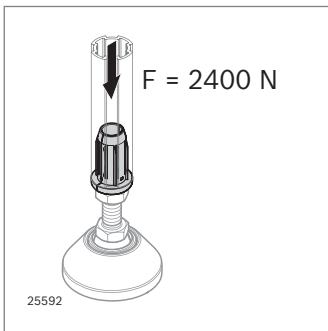




**D28L threaded sleeve, PA**

Permissible bearing load

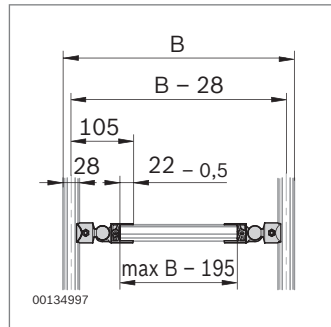
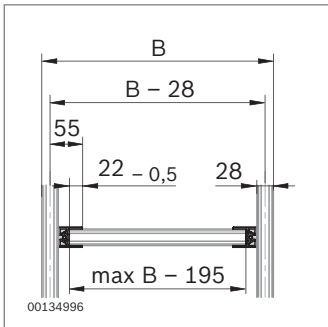
Material shuttle is approved for 60 kg



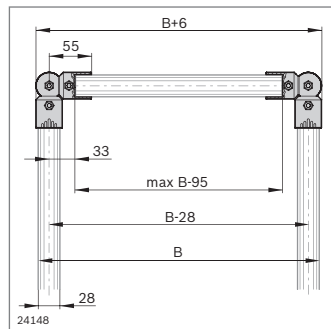
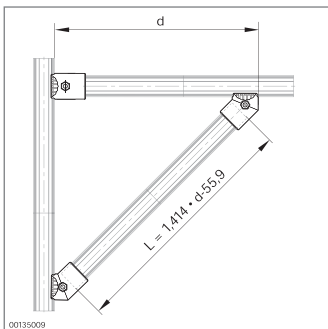
**D28L threaded sleeve, Zn**

Permissible bearing load

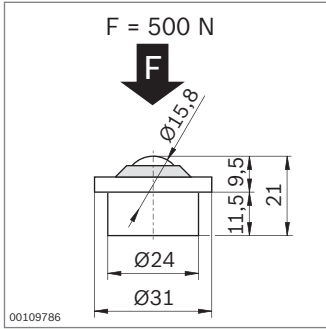
Material shuttle is approved for 100 kg



**Length calculation**



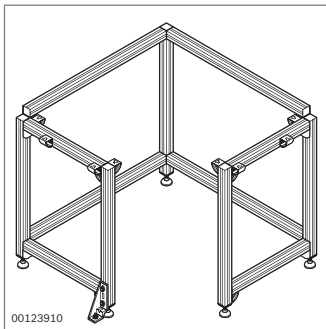
# Manual linking system (EcoFlow)



$F_{max}$ (N)	500
---------------	-----

## EcoFlow ball roller



3 842 541 008 (page 7-10)



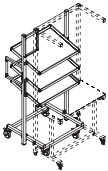
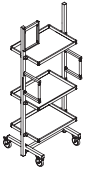
$F_{max}$ (N)	1000	1500
---------------	------	------

## Frame for corner table top

(page 7-4)

	Point load
	Distributed load

# Material shuttles

Version	Max. total weight of workstation material shuttle	Max. total weight of logistics material shuttle
		
Normal	4200 N	4200 N
ESD	4000 N	4000 N

## Workstation material shuttles Logistics material shuttles

$$F_{\Sigma} = F_M + F_Z$$

$F_M$  = Material shuttle weight

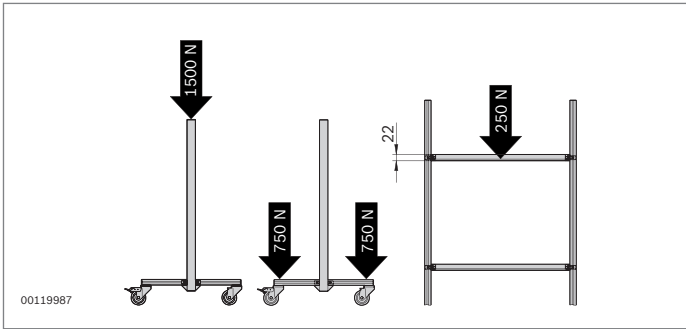
$F_Z$  = Load

**3 842 998 231** (page 8-3)

**3 842 998 230** (page 8-5)

	$T_E$ (mm)	<b>1220</b>	<b>1220</b>	<b>840</b>	<b>765</b>	<b>1000</b>	<b>1000</b>	<b>840</b>	<b>765</b>
	$B_E$ (mm)	<b>1480</b>	<b>840</b>	<b>1480</b>	<b>840</b>	<b>1000</b>	<b>840</b>	<b>1000</b>	<b>840</b>
Plate: Aluminum	$F_B$ (N)	700	700	700	1000				
Plate: PP, SB	$F_B$ (N)					250	280	280	360

$F_B$  is a distributed load and may not occur as a point load.



## Standard material shuttles

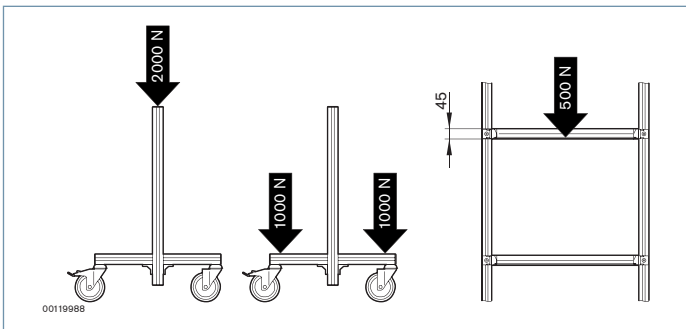
### Economic logistics material shuttle

3 842 515 481 (page 8-7)

3 842 518 120 (page 8-7)

3 842 515 482 (page 8-7)

3 842 518 121 (page 8-7)



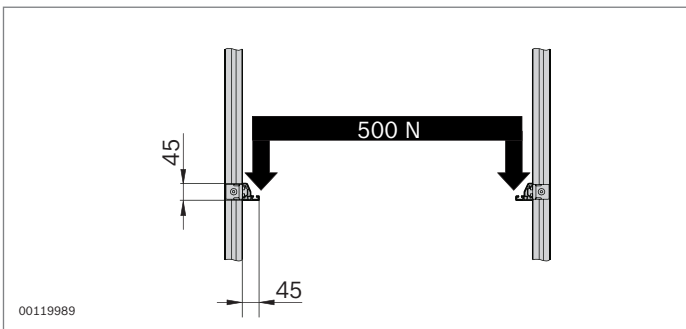
### Basic logistics material shuttle

3 842 515 483 (page 8-7)

3 842 515 484 (page 8-7)

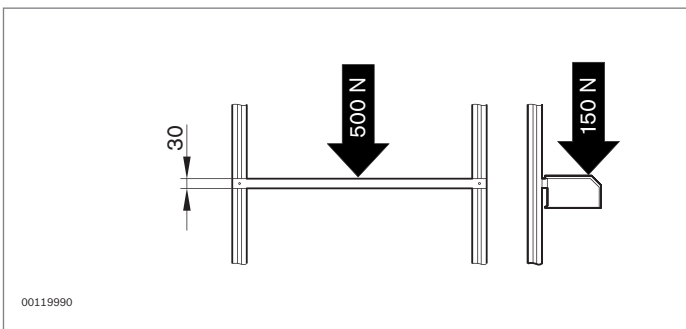
3 842 508 181 (page 8-7)

3 842 508 182 (page 8-7)



### Material shuttle with angle profile

(page 8-8)



### Material shuttle with suspension profile

(page 8-8)

**Profiles**

		<b>Frame profile</b> 22.5x30	<b>Frame profile</b> 22.5x45	<b>Suspension profile</b>	<b>Profile rail</b> 30x45C	<b>Profile</b> 15x22.5
<b>Material number</b>		<b>3 842 992 493/L</b> <b>3 842 557 946</b> (page 12-3)	<b>3 842 992 411/L</b> <b>3 842 557 941</b> (page 12-5)	<b>3 842 993 411/L</b> <b>3 842 537 679</b> <b>3 842 554 157</b> <b>3 842 993 063/L</b> (pages 12-11/12, 12-16, 13-23)	<b>3 842 992 946/L</b> <b>3 842 523 598</b> (page 12-10)	<b>3 842 992 473/L</b> <b>3 842 563 231</b> (page 12-9)
<b>Moment of inertia</b>	$I_x$ (cm <sup>4</sup> )	1.7	6.7	2.0	10.3	0.8
	$I_y$ (cm <sup>4</sup> )	3.0	1.7	0.5	5.6	0.3
<b>Moment of resistance</b>	$W_x$ (cm <sup>3</sup> )	1.5	2.8	2.7	4.2	0.9
	$W_y$ (cm <sup>3</sup> )	2.0	1.3	0.3	3.7	0.6
<b>Profile surface A</b>	(cm <sup>2</sup> )	3.2	3.4	2.0	4.4	1.3
<b>Weight</b>	(kg/m)	0.9	0.9	0.6	1.2	0.3

		<b>U-profile</b>	<b>Section profile</b> 45x45 MV	<b>Angle profile</b>
<b>Part no.</b>		<b>3 842 993 316/L</b> <b>3 842 535 115</b> <b>3 842 995 027/L</b> <b>3 842 541 814</b> (page 5-20)	<b>3 842 993 029/L</b> <b>3 842 537 321</b> (page 7-8)	<b>3 842 992 412/L</b> <b>3 842 557 942</b> (page 12-16)
<b>Moment of inertia</b>	$I_x$ (cm <sup>4</sup> )	10.4	11.8	8.8
	$I_y$ (cm <sup>4</sup> )	8.3	10.5	6.9
<b>Moment of resistance</b>	$W_x$ (cm <sup>3</sup> )	4.6	5.3	3.2
	$W_y$ (cm <sup>3</sup> )	4.1	4.7	2.3
<b>Profile surface A</b>	(cm <sup>2</sup> )	4.4	6.2	4.5
<b>Weight</b>	(kg/m)	1.2	1.7	1.2

## Profiles

		<b>Strut profile</b> 40x40L	<b>Strut profile</b> 45x45L	<b>Strut profile</b> 60x60L	<b>Strut profile</b> 40x80L	<b>Strut profile</b> 45x90L
<b>Material number</b>		<b>3 842 993 724<sup>1)</sup></b>	<b>3 842 993 737<sup>1)</sup></b>	<b>3 842 993 670<sup>1)</sup></b>	<b>3 842 993 728<sup>1)</sup></b>	<b>3 842 993 662<sup>1)</sup></b>
		<b>3 842 993 120<sup>2)</sup></b>	<b>3 842 992 425<sup>2)</sup></b>	<b>3 842 992 443<sup>2)</sup></b>	<b>3 842 993 130<sup>2)</sup></b>	<b>3 842 992 432<sup>2)</sup></b>
<b>Moment of inertia</b>	$I_x$ (cm <sup>4</sup> )	9.1	11.7	32.4	63.4	82.0
	$I_y$ (cm <sup>4</sup> )	9.1	11.7	32.4	17.3	23.6
<b>Moment of resistance</b>	$W_x$ (cm <sup>3</sup> )	4.5	5.2	10.8	15.9	18.2
	$W_y$ (cm <sup>3</sup> )	4.5	5.2	10.8	8.7	10.5
<b>Profile surface A</b>	(cm <sup>2</sup> )	5.6	6.0	9.6	9.9	11.3
<b>Weight</b>	(kg/m)	1.5	1.6	2.6	2.7	3.0

<sup>1)</sup> See "Basic Mechanic Elements – Quick & Easy" catalog (3 842 540 238)

<sup>2)</sup> See "Basic Mechanic Elements" catalog (3 842 540 391)

		<b>Strut profile</b> D28	<b>Strut profile</b> D28x55	<b>Round tube</b> D28L	<b>Round tube</b> D28L, N10	<b>Swivel bearing</b> D28L
<b>Material number</b>		<b>3 842 993 317/L</b> <b>3 842 535 118</b> (page 5-26, 12-7, 12-8)	<b>3 842 993 489/L</b> <b>3 842 537 477</b> (page 5-26)	<b>3 842 996 191/L</b> <b>3 842 557 243</b> (page 6-7)	<b>3 842 996 192/L</b> <b>3 842 557 244</b> (page 6-7)	<b>3 842 548 121</b> <b>3 842 557 298</b> (page 6-10)
<b>Moment of inertia</b>	$I_x$ (cm <sup>4</sup> )	1.5	3.2	1.3	1.2	8.4
	$I_y$ (cm <sup>4</sup> )	1.5	88.3	1.3	2.0	8.4
<b>Moment of resistance</b>	$W_x$ (cm <sup>3</sup> )	1.1	2.3	1.0	0.8	3.7
	$W_y$ (cm <sup>3</sup> )	1.1	23.1	1.0	1.4	3.7
<b>Profile surface A</b>	(cm <sup>2</sup> )	2.4	5.9	1.8	2.6	4.4
<b>Weight</b>	(kg/m)	0.7	1.6	0.5	0.7	1.2

## MATERIAL NUMBER OVERVIEW

0 842 901 309	6-15, 12-10	3 842 514 836	2-26	3 842 520 055	2-22	3 842 530 287	12-11, 12-16
3 842 028 621	2-45	3 842 515 160	2-20, 13-6	3 842 520 056	2-22	3 842 530 306	2-48
3 842 146 815	12-17	3 842 515 481	8-7, 13-22	3 842 521 013	2-20	3 842 532 274	12-12, 12-14
3 842 146 848	12-17	3 842 515 482	8-7, 13-22	3 842 521 510	12-10	3 842 532 752	5-19
3 842 184 738	6-14	3 842 515 483	8-7, 13-22	3 842 521 677	7-4, 12-17	3 842 532 862	5-19
3 842 191 178	2-49	3 842 515 484	8-7, 13-22	3 842 521 817	2-53, 13-9	3 842 532 865	5-19
3 842 191 186	2-49	3 842 515 493	2-49	3 842 521 970	2-52	3 842 532 866	5-19
3 842 218 953	12-10, 12-14	3 842 515 525	2-49	3 842 522 012	2-53	3 842 532 867	5-19
3 842 344 750	3-6, 13-11	3 842 515 547	10-4, 12-12,	3 842 522 087	2-53	3 842 532 870	5-19
3 842 344 751	3-6, 13-11		12-13	3 842 522 130	2-52	3 842 532 871	5-13
3 842 344 752	3-6, 13-11	3 842 515 771	10-3	3 842 522 305	2-52	3 842 532 878	5-26
3 842 344 753	3-6, 13-11	3 842 515 772	10-3	3 842 522 585	2-39	3 842 532 879	5-26, 12-7
3 842 344 756	3-6, 13-11	3 842 515 773	10-4	3 842 522 633	12-14	3 842 532 880	5-19
3 842 344 757	3-6, 13-11	3 842 515 774	10-4	3 842 523 142	3-4	3 842 532 881	5-21
3 842 344 758	3-6, 13-11	3 842 515 775	10-3	3 842 523 561	7-4	3 842 532 883	5-19
3 842 344 759	3-6, 13-11	3 842 515 776	10-3	3 842 523 583	7-4	3 842 532 884	5-19
3 842 344 760	3-7, 13-11	3 842 516 405	10-3	3 842 523 598	13-23	3 842 532 886	5-19
3 842 344 761	3-7, 13-11	3 842 516 406	10-3	3 842 523 910	2-39	3 842 532 887	5-19
3 842 344 764	3-7, 13-11	3 842 516 407	10-4	3 842 523 943	1-2, 2-4	3 842 532 909	2-41
3 842 344 765	3-7, 13-11	3 842 516 704	2-49	3 842 525 457	7-9	3 842 535 115	5-20, 13-23
3 842 344 766	3-7, 13-11	3 842 516 837	12-4, 12-6	3 842 525 737	7-8	3 842 535 118	5-26, 12-7,
3 842 345 081	12-17	3 842 516 838	12-4, 12-6	3 842 525 738	7-8		12-8, 13-24
3 842 346 280	3-6, 13-11	3 842 516 905	2-53	3 842 525 739	7-8	3 842 535 121	5-20
3 842 346 281	3-6, 13-11	3 842 516 908	2-53	3 842 525 740	7-8	3 842 535 122	5-20
3 842 346 282	3-6, 13-11	3 842 517 043	2-41	3 842 525 741	7-8	3 842 535 124	5-20
3 842 346 283	3-6, 13-11	3 842 517 044	2-41	3 842 525 742	7-8	3 842 535 125	12-9
3 842 346 286	3-6, 13-11	3 842 517 045	2-39	3 842 526 034	7-8	3 842 535 136	5-27
3 842 346 287	3-6, 13-11	3 842 517 047	2-40	3 842 526 560	12-17	3 842 535 364	5-21
3 842 346 288	3-6, 13-11	3 842 517 049	2-40	3 842 526 621	3-4	3 842 535 458	12-8
3 842 346 289	3-6, 13-11	3 842 517 051	2-40	3 842 526 622	3-4	3 842 535 470	2-16
3 842 346 290	3-7, 13-11	3 842 517 055	2-41	3 842 526 623	3-4	3 842 535 471	2-16
3 842 346 291	3-7, 13-11	3 842 517 163	2-43	3 842 526 626	3-4	3 842 535 472	2-16
3 842 346 294	3-7, 13-11	3 842 517 164	2-43	3 842 526 627	3-4	3 842 535 473	2-16
3 842 346 295	3-7, 13-11	3 842 517 201	2-39	3 842 526 628	3-4	3 842 535 474	2-16
3 842 346 296	3-7, 13-11	3 842 517 399	12-11	3 842 526 660	3-4	3 842 535 475	2-16
3 842 352 061	7-4, 12-8	3 842 517 400	12-11	3 842 526 665	3-4	3 842 535 476	2-16
3 842 352 088	2-23	3 842 517 401	12-11	3 842 526 671	3-4	3 842 535 477	2-16
3 842 502 151	2-42	3 842 518 120	13-22	3 842 526 672	3-4	3 842 535 478	2-16
3 842 502 153	2-42	3 842 518 121	8-7, 13-22	3 842 526 673	3-4	3 842 535 479	2-16
3 842 502 154	2-42	3 842 518 424	5-26, 12-16	3 842 527 161	4-6, 4-11	3 842 535 480	2-16
3 842 508 181	8-7, 13-22	3 842 519 465	2-53	3 842 527 162	4-6, 4-11	3 842 535 481	2-16
3 842 508 182	8-7, 13-22	3 842 519 530	2-15, 13-6	3 842 527 207	2-40	3 842 535 482	2-16
3 842 513 722	2-48	3 842 519 735	2-20, 13-6	3 842 528 715	12-17	3 842 535 483	2-16
3 842 514 524	2-24	3 842 520 053	2-22	3 842 530 203	2-48	3 842 535 484	2-16
3 842 514 835	2-26	3 842 520 054	2-22	3 842 530 285	2-45	3 842 535 489	2-16

3 842 535 490	2-16	3 842 537 566	2-40	3 842 537 950	7-12	3 842 539 844	2-37
3 842 535 491	2-16	3 842 537 583	7-12	3 842 537 951	5-21	3 842 539 846	2-37
3 842 535 571	7-4	3 842 537 584	7-12	3 842 537 958	5-19	3 842 539 850	2-38
3 842 535 577	12-13	3 842 537 592	7-8	3 842 537 959	5-19	3 842 539 852	2-37
3 842 535 637	12-6	3 842 537 593	7-8	3 842 537 960	5-19	3 842 539 854	2-37
3 842 535 667	7-9	3 842 537 598	2-40	3 842 537 961	5-19	3 842 539 856	2-37
3 842 535 668	7-9	3 842 537 599	2-40	3 842 537 962	5-19	3 842 539 858	2-37
3 842 535 670	10-4	3 842 537 650	2-18, 12-4	3 842 537 963	5-19	3 842 539 860	2-38
3 842 535 683	7-8	3 842 537 651	2-18, 12-6	3 842 537 964	5-19	3 842 539 862	2-37
3 842 536 002	5-26, 12-8	3 842 537 652	5-27	3 842 537 965	5-19	3 842 539 864	2-37
3 842 536 054	7-12	3 842 537 657	5-13	3 842 538 050	5-23	3 842 539 866	2-37
3 842 536 119	12-17	3 842 537 660	5-20	3 842 538 051	5-23	3 842 539 868	2-38
3 842 536 120	12-17	3 842 537 661	5-20	3 842 538 052	5-23	3 842 539 872	2-37
3 842 536 121	12-17	3 842 537 664	7-8	3 842 538 064	5-20	3 842 539 876	2-38
3 842 536 122	12-17	3 842 537 665	7-8	3 842 538 065	5-20	3 842 539 880	2-37
3 842 536 123	12-17	3 842 537 679	12-11,	3 842 538 093	5-27	3 842 539 882	2-37
3 842 536 124	12-17	12-12, 12-16, 13-7, 13-23		3 842 538 094	5-19	3 842 539 884	2-38
3 842 536 125	12-17	3 842 537 687	5-12	3 842 538 098	2-20, 13-6	3 842 539 894	8-10
3 842 536 126	12-17	3 842 537 720	5-21	3 842 538 102	5-23	3 842 539 895	8-10
3 842 536 127	3-8	3 842 537 737	2-20, 13-6	3 842 538 107	5-23	3 842 539 896	8-10
3 842 536 320	2-53	3 842 537 740	7-12	3 842 538 108	5-23	3 842 539 897	8-10
3 842 536 722	5-13	3 842 537 776	5-12	3 842 538 130	5-23	3 842 539 898	8-10
3 842 536 724	5-13	3 842 537 777	5-12	3 842 538 275	12-4	3 842 540 012	8-10
3 842 536 729	12-9	3 842 537 778	5-12	3 842 538 276	12-6	3 842 540 129	2-10
3 842 536 730	5-26	3 842 537 779	5-12	3 842 538 372	5-12	3 842 540 130	2-10
3 842 537 022	12-9	3 842 537 803	5-20	3 842 538 409	2-20, 13-6	3 842 540 197	2-10
3 842 537 113	2-18, 12-4	3 842 537 806	5-20	3 842 538 456	2-17	3 842 540 238	13-24
3 842 537 116	2-18, 12-6	3 842 537 807	5-20	3 842 538 457	2-17	3 842 540 391	13-24
3 842 537 119	5-27	3 842 537 861	12-6, 12-7,	3 842 538 458	2-17	3 842 540 429	2-48
3 842 537 123	2-40		12-10	3 842 538 459	2-17	3 842 540 952	2-10
3 842 537 163	7-8	3 842 537 862	12-4	3 842 538 460	2-17	3 842 541 008	13-20
3 842 537 164	7-8	3 842 537 870	2-42	3 842 538 461	2-17	3 842 541 173	6-8
3 842 537 249	2-15	3 842 537 894	7-11	3 842 538 564	12-8	3 842 541 175	6-8
3 842 537 250	2-15	3 842 537 895	7-11	3 842 538 607	12-13	3 842 541 178	6-9
3 842 537 251	2-15	3 842 537 896	7-11	3 842 538 687	12-13	3 842 541 181	6-9
3 842 537 252	2-15	3 842 537 897	7-11	3 842 538 771	2-19, 13-6	3 842 541 183	6-8
3 842 537 321	7-8, 13-23	3 842 537 898	7-11	3 842 538 772	2-19, 13-6	3 842 541 185	6-7
3 842 537 323	2-39, 9-4	3 842 537 899	7-11	3 842 538 789	2-42	3 842 541 187	6-11
3 842 537 358	2-43	3 842 537 900	7-11	3 842 538 930	12-16	3 842 541 190	6-11
3 842 537 360	2-43	3 842 537 901	7-11	3 842 538 981	12-9	3 842 541 193	6-13
3 842 537 477	5-26, 13-24	3 842 537 911	5-13	3 842 539 806	2-51	3 842 541 228	12-16
3 842 537 558	2-40	3 842 537 944	5-19	3 842 539 838	2-43	3 842 541 236	12-16
3 842 537 560	2-40	3 842 537 945	5-19	3 842 539 839	2-43	3 842 541 296	6-13
3 842 537 562	2-40	3 842 537 947	5-19	3 842 539 840	2-51	3 842 541 814	5-20, 13-23
3 842 537 564	2-40	3 842 537 948	5-21	3 842 539 842	2-37	3 842 542 060	2-37

3 842 542 286	1-2	3 842 546 776	4-6, 4-7	12-8, 12-12, 12-16		3 842 557 272	4-12
3 842 542 287	1-2	3 842 546 854	3-11	3 842 553 618	5-26	3 842 557 298	6-10, 13-24
3 842 543 272	6-11	3 842 547 200	9-4	3 842 553 996	12-11	3 842 557 299	6-10
3 842 543 311	6-14	3 842 547 885	2-47	3 842 554 157	12-11,	3 842 557 433	3-5
3 842 543 480	6-9	3 842 547 886	2-46, 13-9	12-12, 12-16, 13-7, 13-23		3 842 557 434	3-5
3 842 543 494	6-14	3 842 547 887	2-46, 13-9	3 842 554 181	2-41	3 842 557 435	3-5
3 842 544 637	6-14	3 842 548 038	9-4	3 842 554 183	2-39, 9-4	3 842 557 478	3-6, 13-11
3 842 544 768	2-30	3 842 548 117	6-7	3 842 554 410	12-12, 12-14	3 842 557 941	12-6, 13-23
3 842 544 770	2-31	3 842 548 118	6-8	3 842 554 426	12-12	3 842 557 942	12-16, 13-23
3 842 544 772	2-28	3 842 548 119	6-8	3 842 554 490	12-16	3 842 557 946	12-4, 13-23
3 842 544 774	3-11	3 842 548 120	6-12	3 842 554 491	12-16	3 842 557 950	12-10, 12-14
3 842 544 776	3-11	3 842 548 121	6-10, 13-24	3 842 554 708	12-4	3 842 558 253	11-4, 11-5
3 842 544 778	3-11	3 842 548 122	6-10	3 842 554 709	12-4	3 842 558 254	11-4, 11-10
3 842 544 780	3-11	3 842 548 123	6-9	3 842 554 710	12-10, 12-14	3 842 558 255	11-10
3 842 544 789	2-55	3 842 548 126	6-13	3 842 554 711	12-10, 12-14	3 842 558 256	11-4, 11-8
3 842 544 790	2-23	3 842 548 127	6-13	3 842 554 746	5-20	3 842 558 257	11-4, 11-8
3 842 544 797	2-27, 3-8, 6-12	3 842 548 128	6-15	3 842 554 748	5-20	3 842 558 260	11-4, 11-11
		3 842 548 129	6-7	3 842 554 750	4, 6-7	3 842 558 261	11-11
3 842 554 832	2-26	3 842 548 130	6-7	3 842 554 752	6-7	3 842 558 262	11-4, 11-10
3 842 554 833	2-26	3 842 548 131	6-15	3 842 554 754	6-7	3 842 558 263	11-10
3 842 554 834	2-26	3 842 548 132	6-15	3 842 554 758	7-8	3 842 558 264	11-4, 11-11
3 842 544 837	2-27	3 842 548 745	12-13	3 842 554 774	2-51	3 842 558 265	11-11
3 842 546 533	2-45, 13-9	3 842 548 752	5-26, 12-7, 12-8, 12-13, 12-16	3 842 554 776	2-51	3 842 558 266	11-4, 11-7
3 842 546 534	2-46, 13-9			3 842 554 778	2-51	3 842 558 267	11-7
3 842 546 535	2-46, 13-9	3 842 548 753	5-26, 7-4, 12-7, 12-8, 12-13, 12-16	3 842 554 909	2-24	3 842 558 271	11-12
3 842 546 538	2-46, 13-9			3 842 555 600	2-40	3 842 558 273	11-4, 11-11
3 842 546 539	2-46, 13-9	3 842 548 796	12-8	3 842 555 603	2-39, 9-4	3 842 558 274	11-11
3 842 546 540	2-46, 13-9	3 842 548 797	7-4, 12-8	3 842 555 605	2-39, 9-4	3 842 558 276	11-4, 11-5
3 842 546 541	2-47	3 842 548 816	12-9	3 842 555 607	2-39, 9-4	3 842 558 325	3-4
3 842 546 542	2-47	3 842 548 817	12-9	3 842 555 621	2-41	3 842 558 326	3-4
3 842 546 543	2-47	3 842 548 900	2-47	3 842 555 622	2-41	3 842 558 327	3-4
3 842 546 546	2-47	3 842 549 427	9-5	3 842 555 641	9-3	3 842 558 328	3-4
3 842 546 547	2-47	3 842 549 428	9-5	3 842 555 673	2-29	3 842 558 329	3-4
3 842 546 744	2-27	3 842 549 435	9-5	3 842 555 685	3-6, 13-11	3 842 558 330	3-4
3 842 546 745	2-27	3 842 549 442	9-5	3 842 557 110	11-4	3 842 558 331	3-4
3 842 546 747	3-11	3 842 549 449	9-5	3 842 557 111	11-4, 11-5	3 842 558 332	3-4
3 842 546 762	4-6, 4-8	3 842 551 110	11-5	3 842 557 203	12-12	3 842 558 333	3-4
3 842 546 763	4-6, 4-8	3 842 551 582	12-11,	3 842 557 206	8-10	3 842 558 334	3-4
3 842 546 766	4-6, 4-9	12-12, 12-16		3 842 557 209	12-13	3 842 558 454	2-50
3 842 546 767	4-6, 4-9	3 842 551 583	12-11,	3 842 557 216	8-10	3 842 558 625	2-8
3 842 546 768	4-6, 4-10	12-12, 12-16		3 842 557 243	4, 6-7, 13-24	3 842 558 627	2-8
3 842 546 769	4-6, 4-10	3 842 552 151	5-12, 5-20	3 842 557 244	6-7, 13-24	3 842 558 629	2-8, 13-4
3 842 546 772	4-12	3 842 552 212	2-38	3 842 557 250	6-7	3 842 558 636	2-37
3 842 546 773	4-12	3 842 552 214	2-37	3 842 557 251	6-7	3 842 559 310	3-4
3 842 546 775	4-12	3 842 553 611	5-26, 12-7,	3 842 557 271	4-12	3 842 559 345	6-16

3 842 559 346	6-16	3 842 563 247	2-36	3 842 993 317/L	5-26, 12-7, 12-8, 13-24	3 842 998 196	5-11, 13-15
3 842 559 380	2-41, 6-12	3 842 563 547	11-4, 11-9	3 842 993 321/L	5-12	3 842 998 230	8-5, 13-21
3 842 559 381	2-41	3 842 563 548	11-4, 11-9	3 842 993 322/L	5-12	3 842 998 231	8-3, 13-21
3 842 559 382	2-41	3 842 564 084	2-39	3 842 993 411/L	12-11, 12-12, 12-16, 13-7, 13-23	3 842 998 249	13-13
3 842 559 392	2-34, 2-46, 13-9	3 842 564 085	2-39	3 842 993 431/L	5-12	3 842 998 250	2-16, 12-17
3 842 559 393	2-34	3 842 564 086	2-39	3 842 993 432/L	5-12	3 842 998 256	2-19, 13-6
3 842 559 394	2-34	3 842 564 106	2-40	3 842 993 446/L	3-4	3 842 998 257	2-20
3 842 559 395	2-34	3 842 564 107	2-40	3 842 993 489/L	5-26, 13-24	3 842 998 258	7-5
3 842 559 888	11-4	3 842 564 128	9-6	3 842 993 512/L	7-8	3 842 998 278	7-4, 7-6
3 842 559 889	11-4, 11-9	3 842 564 145	2-8	3 842 993 517/L	3-4	3 842 998 322	5-9, 13-13
3 842 559 921	2-10	3 842 564 155	2-8	3 842 993 527/L	3-4	3 842 998 332	5-7, 13-13
3 842 559 922	2-10	3 842 564 212	12-7	3 842 993 615/L	5-23	3 842 998 350	2-5
3 842 559 923	2-10	3 842 564 214	5-26	3 842 993 617/L	5-23	3 842 998 381	5-16, 13-15
3 842 559 931	2-10	3 842 564 223	5-20	3 842 993 662	2-44	3 842 998 382	5-16, 13-15
3 842 559 932	2-10	3 842 564 686	3-5	3 842 993 670	2-45	3 842 998 383	5-18, 13-15
3 842 559 933	2-10	3 842 564 687	3-5	3 842 993 703/L	8-10	3 842 998 384	5-18, 13-15
3 842 559 940	2-10	3 842 564 688	3-5	3 842 993 706/L	12-13	3 842 998 385	5-16, 13-16
3 842 559 942	2-12	3 842 564 695	4-6, 4-7	3 842 993 710/L	12-12	3 842 998 386	5-18, 13-16
3 842 559 942	2-12	3 842 564 696	4-6, 4-7	3 842 993 728	2-44	3 842 998 387	5-16, 13-15
3 842 559 943	2-12	3 842 992 411/L	12-6, 13-23	3 842 993 737	7-4, 12-8, 12-12, 12-13, 12-16, 13-24	3 842 998 388	5-18, 13-15
3 842 559 944	2-12	3 842 992 412/L	12-16, 13-23	3 842 993 737/L	12-7	3 843 558 255	11-4
3 842 559 945	2-12	3 842 992 425	5-26, 13-24	3 842 993 1202	13-24	3 843 558 261	11-4
3 842 559 946	2-12	3 842 992 425/L	5-26	3 842 993 6621	13-24	3 843 558 263	11-4
3 842 559 948	2-10	3 842 992 432	13-24	3 842 993 6701	13-24	3 843 558 265	11-4
3 842 559 950	2-10	3 842 992 443	13-24	3 842 993 7241	13-24	3 843 558 274	11-4
3 842 559 954	2-10	3 842 992 473/L	12-9, 13-23	3 842 993 7281	13-24	3 844 558 267	11-4
3 842 559 954	2-10	3 842 992 493/L	12-4, 13-23	3 842 994 979/L	2-19		
3 842 559 957	2-8	3 842 992 946	12-10, 12-14, 13-23	3 842 994 988/L	7-8		
3 842 559 959	2-8	3 842 992 946/L	12-10, 13-23	3 842 994 989/L	7-8		
3 842 559 961	2-8	3 842 993 029/L	7-8, 13-23	3 842 995 007/EL	7-11		
3 842 559 963	2-8	3 842 993 063/L	12-11, 12-12, 12-16, 13-7, 13-23	3 842 995 008/L	7-8		
3 842 559 965	2-8	3 842 993 071/L	3-4	3 842 995 017/EL	7-11		
3 842 559 967	2-8	3 842 993 072/L	3-4	3 842 995 027/L	5-20, 13-23		
3 842 562 077	5-13	3 842 993 073/L	3-4	3 842 996 191/L	6-7, 13-24		
3 842 562 083	6-17	3 842 993 120	2-48	3 842 996 192/L	6-7, 13-24		
3 842 562 090	2-19	3 842 993 130	13-24	3 842 996 432	7-8		
3 842 562 115	2-41, 6-12	3 842 993 316/L	5-20, 13-23	3 842 998 110	2-13, 13-3		
3 842 562 624	11-4, 11-8			3 842 998 155	2-17, 13-5		
3 842 562 625	11-4, 11-8			3 842 998 183	2-17, 13-5		
3 842 562 823	11-4, 11-9			3 842 998 184	2-17, 13-5		
3 842 562 824	11-4, 11-9						
3 842 562 825	11-9						
3 842 563 231	12-9, 13-23						
3 842 563 232	12-9						
3 842 563 245	2-35						
3 842 563 246	2-35						

**INDEX**

- A**
- Accessories** 4-12, 5-13, 5-21, 7-12, 9-5, 10-4, 13-3, 13-6
- Accessory upright** 12-8
- ActiveCockpit** 11-3, 11-11
- Application software 11-8
  - AppConnector 11-11
  - App Diagram 11-8
  - Card Identification 11-11
  - DeviationManager 11-11
  - LeanIndicator 11-9
  - ValueStreamManager 11-9
  - WebFrame 11-10
  - WebFrame CheckIn 11-10
  - Basic package and licenses 11-5
  - Software 11-5
- Adapter** 6-11
- D28L adapter mount 6-12
  - N8, N10 adapter 6-11
  - N10/30 adapter 6-11
  - N10/45 adapter 6-11
  - XLean adapter 6-13
- Air bar** 2-23
- AppConnector** 11-11
- App Diagram** 11-8
- Applications** 2-21
- Hanger 2-21
  - Suspension profile 2-21
- Application software,**
- ActiveCockpit** 11-8
- AppConnector 11-11
  - App Diagram 11-8
  - Area Manager 11-7
  - Card Identification 11-11
  - DeviationManager 11-11
  - LeanIndicator 11-9
  - ValueStreamManager 11-9
  - WebFrame 11-10
  - WebFrame CheckIn 11-10
- Area Manager** 11-7
- Armrest** 2-49
- Adjustable armrest 2-49
  - Armrest with pad 2-49
- Attachment plate** 9-5
- B**
- Ball roller** 7-10, 13-20
- Base drawer** 2-45, 13-9
- Basic** 2-16, 2-17, 2-20, 4-6, 4-7, 8-3, 8-5, 8-7, 9-3, 9-4, 12-5, 13-5, 13-6, 13-22
- Bottle holder** 2-48
- Brake** 5-13
- Bridge** 5-13
- D28 bushing** 6-10
- D28L base plate** 6-15, 6-16
- EcoShape base plate** 6-16
- C**
- Cabinet** 2-45
- Cable bracket + adapter** 6-12
- Card Identification** 11-11
- CardReader** 11-12
- Case lifters**
- Accessories 9-5
  - Electric 9-3
- Cloth holder** 2-48
- Comfort sensor unit** 9-4
- Components**
- Conductive mat insert 2-54
  - Conveyor tracks 5-11, 5-19, 7-7
  - Cross ties 5-25
  - Damping ring 2-54
  - ESD applications 2-53
  - FiFo station 8-9
  - Grounding cable 2-54
  - Height-adjustable workstation 2-9
  - Potentialfix 2-54
  - Set of grounding components 2-54
  - Wrist band 2-54
- Conductive mat insert** 2-54
- Connecting plug** 2-41
- Connection cable** 2-39
- Connector**
- 0°-90° connector 6-9
  - 0°-90° D28 connector 6-9
  - 45° connector 6-8
  - 90° connector 6-8
- Container mount** 3-2, 3-8
- Containers** 2-46, 13-9
- Castors 2-47
  - Cover 2-47
  - Drawer insert 2-47
- Control unit** 2-9
- Conveyor media** 13-16
- Conveyor tracks** 2-13, 3-10, 5-2, 5-4, 5-5, 5-7, 5-9, 5-11, 5-12, 5-15, 5-17, 5-19, 5-21, 5-22, 5-23, 7-1, 7-2, 7-7, 13-15, 13-16
- Components 5-12, 5-19, 7-7
  - EcoFlow 7-5
  - with rail holder 13-17
  - with stop plate 13-17
  - Lean 5-19, 13-15, 13-16, 13-17
  - with rail holder 13-15, 13-16
  - with stop plate 5-17, 7-6, 13-15, 13-16
  - XLean 13-15, 13-16
- Corner piece** 7-10, 12-4, 12-6
- Cover** 3-6, 13-11
- Cover cap** 5-26, 6-7, 7-4, 7-9, 12-7, 12-8, 12-9, 12-11, 12-12, 12-13, 12-16
- Cross connector** 6-6, 6-9, 13-18
- Cross ties** 5-25, 13-14
- Double tubular cross tie 5-25
  - Profile cross tie 5-25
  - Tubular cross tie 5-25
  - Tubular cross tie with bracket 5-25
- Cup holder** 2-48
- D28 corner bracket** 6-9
- Container mount** 2-25, 2-27, 6-12, 13-11

- D**
- Damping ring** 2-53, 2-54
  - DeviationManager** 11-11
  - Double tubular cross tie** 5-5, 5-7, 5-9, 5-13, 5-21, 5-25, 5-26, 7-12, 13-14
  - Drawer cabinet** 2-46, 13-9
    - Drawer insert 2-47
  - Drawer insert** 2-47
  - Dynamic ESD** 4-6, 4-10, 4-12
  - Dynamic PU** 4-6, 4-8, 4-12
  - Dynamic textile** 4-6, 4-9, 4-12
  - Dynamic clean** 4-6, 4-11
- E**
- EcoFlow** 7-1, 7-3
    - Accessories 7-12
    - Application examples 7-3
    - Ball roller 7-10, 13-20
    - Brake 7-12
    - Conveyor track 7-5
    - Conveyor track components 7-7
    - Corner piece 7-10
    - Corner pieces 7-12
    - Cover cap 7-9
    - Flow rack, flow rack systems 5-9, 13-12
    - Frame for corner table top 13-20
    - Protective cover 7-12
    - Roller fixation 7-9
    - Stop 7-10
    - Stop gates and return stops 7-11
    - Stop plate 7-4, 7-8, 13-17
    - Transverse conveyor 7-10
  - EcoShape** 6-3, 6-5, 13-18
    - 0°-90° connector 6-9
    - 0°-90° D28 connector 6-9
    - 45° connector 6-8
    - 45° D28L strut 6-8
    - 90° connector 6-8
  - Cable bracket + adapter 6-12
  - Connector 13-18
  - Container mount 6-12
  - Cover cap 6-7
  - Cross connector 6-9
  - D28 bushing 6-10
  - D28L adapter mount 6-12
  - D28L base plate 6-15, 6-16
  - D28L corner bracket 6-9
  - D28L cross tie 13-18
  - D28L/D28L hinge 6-13
  - D28L/- hinge 6-13
  - D28L, N10 stopper 6-15
  - D28L retaining ring 6-10
  - D28L round tube 6-7, 13-24
  - D28L round tube, N10 6-7, 13-24
  - D28L swivel bearing 6-10
  - D28L threaded sleeve 13-19
  - D28L threaded sleeve, PA 6-7
  - D28L threaded sleeve, Zn 6-8
  - EcoShape base plate 6-16
  - Impact protection 6-14
  - Insertion aid 5-22
  - Length calculation 13-19
  - N8, N10 adapter 6-11
  - N10/30 adapter 6-11
  - N10/45 adapter 6-11
  - Parallel connector 6-8
  - Ring + spring hook 6-15
  - Slide rail 6-7
  - Snap-in clip 6-14
  - Tension wire 6-17
  - Variifix block (PA) 6-14
  - Variifix block (Zn) 6-14
  - XLean adapter 6-13
  - Ergonomic mat** 2-55
  - ESD applications** 2-53
    - Conductive mat insert 2-54
    - Damping ring 2-54
    - Grounding cable 2-54
    - Potentialfix 2-54
    - Set of grounding components 2-54
  - Wrist band 2-54
  - Expanding nut** 2-51
  - Stool** 4-6, 4-7
- F**
- EcoFlow flow rack** 5-9, 13-12
  - FiFo station** 8-9
    - Components 8-10
  - Filler hopper** 3-5
  - Flexible bridge** 5-13
  - Flow rack systems** 5-3, 13-12
    - Cross ties 5-25
    - EcoFlow flow rack 5-9
    - Insertion aid 5-22
    - Labeling clip 5-27
    - Lateral guide 5-22
    - Lean flow rack 5-7
    - Reinforcement 5-22
    - Transport guide 5-23
    - XLean flow rack 5-5
  - Footrest** 2-19
    - Basic 2-20
    - Economic 2-19
  - Forks** 9-5
  - Foundation bracket** 12-17
  - Frame for corner table top** 7-4, 13-20
  - Grab trays** 3-2, 3-7, 3-8
  - Lean flow rack** 5-7, 13-12
    - Accessories 5-21
    - Conveyor tracks – components 5-19
    - Conveyor tracks with rail holder 5-15
    - Conveyor tracks with stop plates 5-17
  - XLean flow rack** 5-5, 13-12
    - Accessories 5-13
    - Conveyor tracks 5-11
    - Conveyor tracks – components 5-12

<b>G</b>		<b>K</b>		<b>Material shuttles</b>	13-21
<b>Grab container rack</b>	3-2, 3-9, 12-11	<b>Keyboard holder</b>	2-52	– Basic logistics	8-7, 13-22
<b>Grab containers</b>	3-6, 13-11	<b>Keyboard shelf</b>	2-50	– Economic logistics	8-7, 13-22
– Vario	3-3	<b>L</b>		– Logistics	8-5, 8-7, 13-21
<b>Grab ledge</b>	3-2, 3-3, 3-4, 3-6, 3-7, 3-10, 3-11, 13-11	<b>Labeling clips</b>	2-18, 3-8, 5-2	– Standard	13-22
<b>Grab trays</b>	2-27	<b>Lateral guide</b>	5-22, 7-6, 12-2, 13-16	– with angle profile	8-8, 13-22
<b>Grounding cable</b>	2-54	<b>Lean</b>	5-7	– with suspension profile	8-8, 13-22
<b>Guide plate 30x30</b>	2-31	– Accessories	5-21	– Workstation	8-3, 13-21
<b>H</b>		– Brake	5-21	<b>Mount</b>	5-13
<b>Hand switch</b>	2-9, 9-4	– Conveyor track	13-15, 13-16, 13-17	<b>Mouse holder</b>	2-52
– Basic hand switch	9-4	– Conveyor tracks –		<b>N</b>	
– Comfort hand switch	9-4	components	5-19	<b>Network strip</b>	2-38
<b>Hanger</b>	2-21, 12-10, 13-8	– Conveyor tracks with		<b>O</b>	
<b>Height-adjustable workstation</b>	2-5	rail holder	5-15	<b>Optional accessories</b>	2-11
– Components	2-9	– Conveyor tracks with		<b>P</b>	
– Optional accessories	2-11	stop plates	5-17	<b>Parallel connector</b>	6-8
<b>Hinge</b>		– Flexible bridge	5-21	<b>Point and distributed loads</b>	13-3
– D28L/D28L hinge	6-13	– Flow rack, flow rack systems	13-12	<b>Potentialfix</b>	2-54
– D28L/- hinge	6-13	– Stop plate	5-18	<b>Power strip</b>	2-38
<b>Holder</b>	2-48	– Stop plates	5-17	<b>Profile cross tie</b>	5-26
– Bottle holder	2-48	<b>LeanIndicator</b>	11-9	<b>Profiles</b>	13-23
– Cloth holder	2-48	<b>LED system lamp</b>	2-35	– 15x22.5 profile	12-9
– Cup holder	2-48	<b>LED system lamps</b>	13-10	– 30x30 profile	8-10
– Holder for double		<b>Logistics material shuttle</b>	8-5, 8-7	– Angle profile	13-23
tubular cross tie	5-21	– Basic	8-7, 13-22	– Frame profile	13-23
<b>Holder for hand switch</b>	9-4	– Economic	8-7, 13-22	– Profile 45 x 45L	5-26
<b>I</b>		<b>Loop cable bracket</b>	2-41	– Profile rail	13-23
<b>Impact protection</b>	6-6, 6-14	<b>M</b>		– Round tube	13-24
<b>Infoboards</b>		<b>Mains cable</b>	2-9, 2-39, 9-4	– Section profile	13-23
– Accessories	10-4	<b>Manual linking system</b>	13-20	– Strut profile	13-24
– Economic	10-3	– EcoFlow ball roller	7-10, 13-20	– Suspension profile	2-21, 13-23
– Mobile	10-4	– Frame for corner		– Swivel bearing	13-24
– Wall	10-3	table top	7-4, 13-20	– U-profile	13-23
<b>Information boards</b>	2-42	<b>Material shelves</b>	2-17	<b>Protective cover</b>	7-12
– ISO information boards	2-43	– Basic	2-17, 13-5	<b>Protective sheet</b>	9-6
<b>Insertion aid</b>	5-22	– Economic	2-17		
		– Labeling clips	2-18		
		– Self-assembly elements	12-3, 12-5		

**R**

<b>D28L retaining ring</b>	6-10
<b>Reinforcement</b>	5-22
<b>Return stop</b>	7-11
<b>Roller fixation</b>	7-9
<b>Round tube</b>	6-1
– D28L round tube	6-7, 6-11, 6-13, 6-17
– D28L round tube, N10	6-7
– D28 round tube	5-26, 6-5, 12-7, 12-8
<b>Rubber profile</b>	2-19
<b>Reinforcement</b>	12-2, 12-9

**S**

<b>45° D28L strut</b>	6-8
<b>D28L, N10 stopper</b>	6-15
<b>D28L swivel bearing</b>	6-10
<b>LED system lamp</b>	13-10
<b>Ring + spring hook</b>	6-15
<b>Section link</b>	5-13
<b>Self-assembly elements</b>	12-1
– 180° tool hanger	12-14
– Accessory upright	12-8
– Conveyor level	12-7
– Foundation bracket	12-17
– Grab containers	12-11
– Hanger	12-10
– Lateral guide	12-9
– Material shelf Basic	12-5
– Material shelf Economic	12-3
– Material shuttles	12-15
– Reinforcement	12-9
– Supporting arms	12-12, 12-13
– Supporting bracket	12-17
– Suspension profile	12-11
– Tool shelf	12-11
<b>Set of grounding components</b>	2-54
<b>Slide-in holder</b>	2-44
<b>Slide rail</b>	6-7
<b>Snap-in clip</b>	6-14

<b>Socket strip</b>	2-37
<b>Software, ActiveCockpit</b>	11-5
– Basic package and licenses	11-5
<b>Spiral hose</b>	2-23
<b>Spring pull</b>	2-22
<b>Stop</b>	7-10
<b>Stop gate</b>	7-11
<b>Stop plate</b>	3-11
– EcoFlow	7-3, 7-8, 13-17
– Lean	5-17, 5-20, 13-15, 13-16
<b>Strut extension</b>	2-15
<b>Support frame</b>	2-20
<b>Supporting arm</b>	2-52
– Self-assembly elements	12-12, 12-13
<b>Supporting bracket</b>	12-17
<b>Suspension profile</b>	2-21, 12-11, 13-7
<b>Suspension strap</b>	9-5
<b>Swivel work chair accessories</b>	4-12
– Armrests	4-12
– Circular footrest	4-12
– Foot support	4-12
<b>Swivel work chairs</b>	
– Basic	4-7
– Dynamic clean	4-11
– Dynamic ESD	4-10
– Dynamic PU	4-8
– Dynamic textile	4-9
<b>System lamps</b>	2-34, 13-10
<b>T</b>	
<b>180° tool hanger</b>	12-14
<b>D28L threaded sleeve, PA</b>	6-7, 13-19
<b>D28L threaded sleeve, Zn</b>	13-19
<b>Table frame</b>	2-15
<b>Table top</b>	2-16
– Basic	2-16
<b>Table top support</b>	12-17
<b>Technical data</b>	13-1
<b>Tension wire</b>	6-6, 6-17
<b>TFT monitor bracket</b>	2-51
<b>Tool holders</b>	2-24, 2-25

– D52	2-26
– D95	2-28
– L105	2-30
– TAPE 50 mm	2-29
<b>Tool shelf</b>	2-24
– Self-assembly elements	12-11
<b>T-plug</b>	2-41
<b>Transparent plastic sleeve</b>	2-42
<b>Transport guide</b>	5-23
<b>Transverse conveyor</b>	7-10
<b>Tube clamp</b>	5-21, 6-13
<b>Tubular cross tie</b>	5-25, 13-14

**V**

<b>ValueStreamManager</b>	11-9
<b>Vario grab containers</b>	3-3
<b>Variofix block (PA)</b>	
– PA	6-14
– Zn	6-14

**W**

<b>Wall</b>	10-3
<b>WebFrame</b>	11-10
<b>WebFrame CheckIn</b>	11-10
<b>Workstation lighting</b>	2-32
– DIM connection cable	2-36
– System lamp LED basic	2-35
– System lamp LED economic	2-34
<b>Wrist band</b>	2-54
<b>Workstation</b>	2-3, 2-13, 13-3, 13-6
– Accessories	13-6

**X**

<b>XLean5-5</b>	
– Accessories	5-13
– Conveyor tracks	5-11
– Conveyor tracks – components	5-12
– Flow rack, flow rack systems	5-5, 13-12

**Bosch Rexroth AG**

Postfach 30 02 07  
70442 Stuttgart  
[www.boschrexroth.com](http://www.boschrexroth.com)

**Evolution Motion Solutions**

13835 Senlac Dr, Farmers Branch, TX 75234  
800-569-9801  
[www.evolutionmotion.com](http://www.evolutionmotion.com)

**Further information online:**



**Find your local contact person here:**  
<https://addresses.boschrexroth.com>



**Rexroth media directory**  
[www.boschrexroth.com/mediadirectory](http://www.boschrexroth.com/mediadirectory)



The data specified above only serves to describe the product. No statements concerning a certain condition or suitability for a certain application can be derived from our information. The information given does not exempt the user from the obligation of own judgment and verification. It must be remembered that our products are subject to a natural process of wear and aging.

3 842 538 281 (2021-08)  
© Bosch Rexroth AG 20201  
Subject to changes!